

2025

CATALOGO GENERALE

general catalogue



everything you cook





UNA FAMIGLIA CHE GENERA FAMIGLIE

Gli albori della nostra azienda...

A FAMILY THAT INSPIRES FAMILIES
The FAMA story, how it all started...

I capostipiti che diedero origine alla famiglia
The progenitors of the family



Il primo container: si iniziano a fare le cose in grande
Getting bigger: our first container loading

Lavorare tanto, mai prendersi troppo sul serio
Work hard, have fun



Le prime fiere anni 90'
Our first trade fairs in the nineties



La nostra "famiglia" allargata
The big FAMA family

Ad honorem



...la storia continua
to be continued...





Mario Fabbri
 Fondatore Fama Industrie
 Founder Fama Industrie
 1953



Grattugie
 Graters

**Il vero valore,
 quello umano**
 The true value,
 the human one



Tritacarne
 Meat Mincers



Tritacarne Grattugia
 Meat Mincer Graters



Serie Retrò
 Retrò Series

Mixer Heavy
 Mixer Heavy Duty Pro Line



Mixer Light
 Mixer Light Duty Line



Pelatori
 Mussel washer
 and popato peeler



Presshamburger
 Burger press

Affettatrici
 Slicer Machines



Tagliaverdure
 Vegetable Shredder





IN COSTANTE ESPANSIONE

ONGOING EXPANSION
ACROSS THE GLOBE

Fama Industrie nel mondo

Da Rimini, in Emilia Romagna, al mondo intero, Fama Industrie vanta la propria presenza in tutti i continenti e distribuisce in più di 100 paesi macchinari altamente qualificati, con accessori studiati appositamente per ogni specifica esigenza, costruiti con estrema precisione e con l'utilizzo di materiali di qualità.

Prodotti di qualità Made in Italy

La nostra Forza consiste nel mettere a disposizione della clientela varie tipologie di macchine, diversificate in base all'utilizzo di varie dimensioni e capacità. Queste caratteristiche permettono di scegliere tra una vasta gamma di prodotti, tutti realizzati secondo gli stessi criteri di qualità e affidabilità, ma completamente versatili e adattabili a ogni situazione e ad ogni attività.

Da sempre progettiamo, costruiamo, importiamo e distribuiamo prodotti affidabili e resistenti, con lo scopo di permettere a tutti i clienti in ogni angolo del mondo un utilizzo semplice e duraturo. Dopo una minuziosa selezione e accurati test di verifica sui prodotti importati, Fama Industrie garantisce la massima qualità e affidabilità dei prodotti commercializzati.

Fama worldwide

From our state-of-the-art factory in Rimini, Emilia-Romagna, we ship all over the world equipment produced with the highest quality components, which combined with class-leading design, innovation and expertise, mean the end result is of the highest standard.

Italian made quality equipment

From testing new designs and materials to looking for ways to improve guarantees and reduce cost of service, we continue to expand our portfolio and footprint to offer innovative products to help the food service industry to prepare, cook and serve. All available in different sizes and capacity, providing excellent solutions that fully satisfy the needs of catering and hospitality environments.

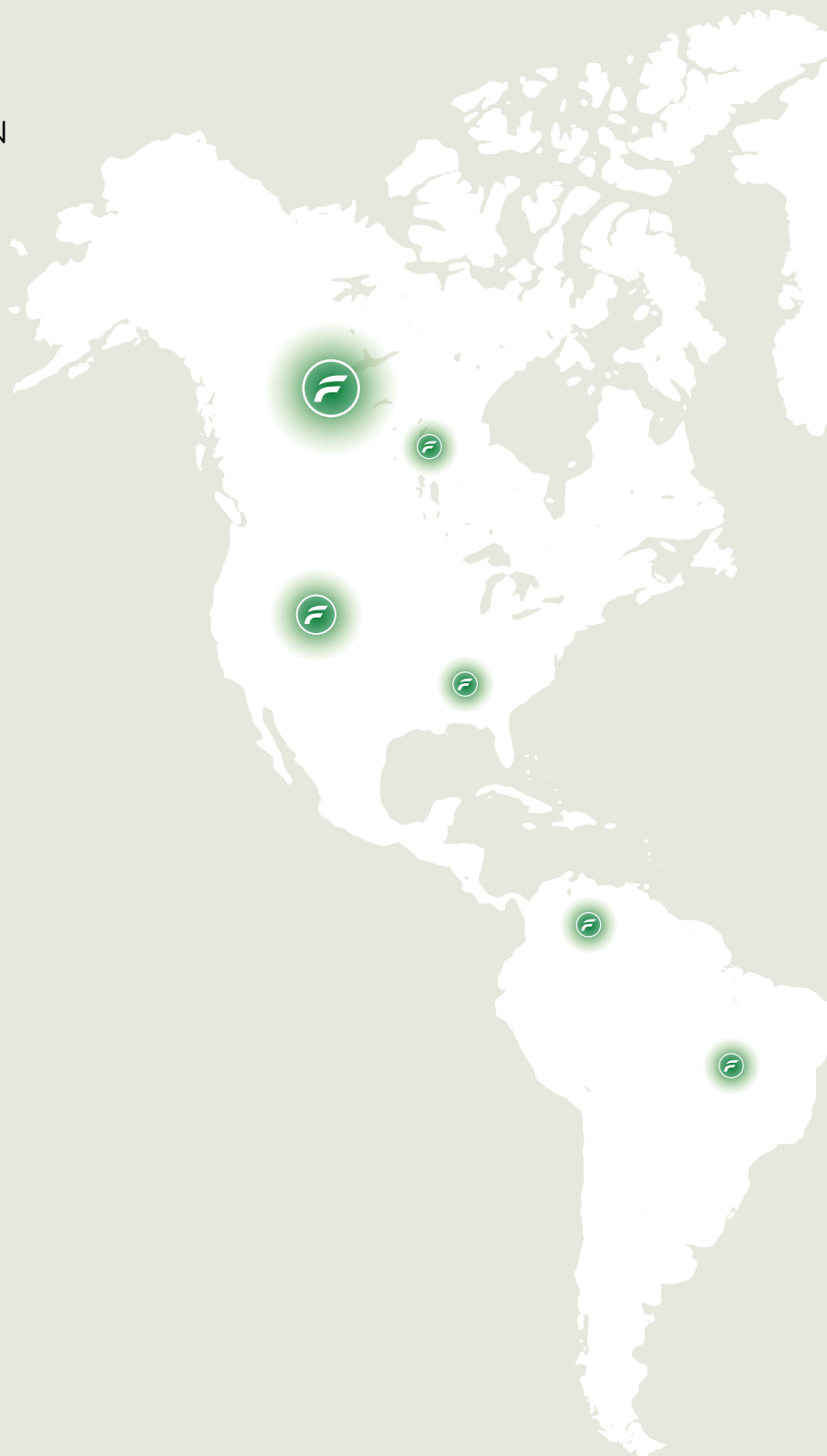



EUROPA

LITUANIA
FINLANDIA
LETTONIA
ESTONIA
POLONIA
UNGHERIA
REPUBBLICA CECA
CROAZIA
SLOVENIA
SERBIA
GRAN BRETAGNA
BOSNIA ERZEGOVINA
OLANDA
SLOVACCHIA
PORTOGALLO
SVEZIA

BELGIO
SPAGNA
FRANCIA
GERMANIA
NORVEGIA
SVIZZERA
AUSTRIA
RUSSIA
UCRAINA
BULGARIA
ROMANIA
ALBANIA
REPUBBLICA
MOLDAVA
MACEDONIA

ASIA

EMIRATI ARABI
BAHREIN
GEORGIA
ISRAELE
IRAQ
IRAN
KUWAIT
OMAN
QATAR
ARABIA SAUDITA
SRI LANKA

MALDIVE
CINA
HONG KONG
FILIPPINE
VIETNAM
SINGAPORE
INDONESIA
THAILANDIA
GIAPPONE

AMERICA

CANADA
STATI UNITI
VENEZUELA
COLOMBIA

OCEANIA

AUSTRALIA



QUALITÀ CERTIFICATA

QUALITY, TRUST AND TECHNOLOGY
AT THE HEART OF OUR HISTORY

Il cliente al centro

Da sempre attribuiamo fondamentale importanza alla soddisfazione del cliente. Attualmente dagli uffici commerciali numerosi addetti sono pronti ad assistere rivenditori e distributori grazie alla padronanza delle lingue più diffuse e all'approfondita conoscenza dei prodotti, supportandoli e aiutandoli anche attraverso la documentazione tecnica e libretti d'uso.

Inoltre sul sito www.famaindustrie.com sono disponibili tutte le fotografie dei nostri articoli disponibili, le schede tecniche e i video dimostrativi delle macchine principali.

Efficienza e versatilità

Fama Industrie è consapevole dell'importanza della velocità, infatti potendo contare sugli ampi e moderni stabilimenti di produzione e stoccaggio, ad oggi riusciamo ad offrire quantità imponenti di prodotti e ricambi in pronta consegna, anche in sole 24 ore.

Certificazioni CE e CB

FAMA INDUSTRIE al fine di certificare la sicurezza e la qualità delle proprie macchine. Ha scelto di sottoporle agli scrupolosi controlli di due enti di certificazione di chiara reputazione internazionale (IMQ e DEKRA). FAMA INDUSTRIE inoltre partecipa all'attività di normazione, sia a livello italiano che europeo, prendendo parte ai comitati tecnici preposti alla redazione e aggiornamento delle norme di sicurezza.

Un serio e lungo percorso che mira a fornire prodotti di alta qualità, tali da soddisfare la fiducia dei nostri clienti che da sessant'anni hanno scelto la nostra affidabilità. FAMA: la forza della tradizione al passo con i tempi!

Customer focus beyond the call of duty

One of our key brand values is customer focus. We're proud of our quick response to all enquiries, orders and service calls. Our customers associate us with the winning combination of quality, value and longevity. FAMA INDUSTRIE's name is also a mark of personal service, we provide an unparalleled after-sales service. Our sales team are trained to support our network of distributors and retailers in choosing the best product. Additionally, on our website further information and videos are available.

In addition, you can visit our website famaindustrie.com to browse data sheets, product pictures and videos.

Efficiency and versatility

We're dedicated to satisfying customer needs with next day deliveries and stock availability of an extensive range.

CE e CB certifications

FAMA INDUSTRIE has chosen to verify the safety and the quality of its equipment: because of that two internationally prominent Certified Bodies (IMQ and DEKRA) have scrutinized carefully the machines.

FAMA INDUSTRIE participates in the standardization process, both in Italy and in Europe: it takes part actively into the chief technical committee for writing and revising safety standards.

Thus granting the highest-grade quality products to those customers who have been choosing FAMA, and the reliability of its family run business, for nearly 60 years. FAMA: the strength of tradition that keeps up with times!



Federazione delle Associazioni Nazionali
dell'Industria Meccanica Varia ed Affine

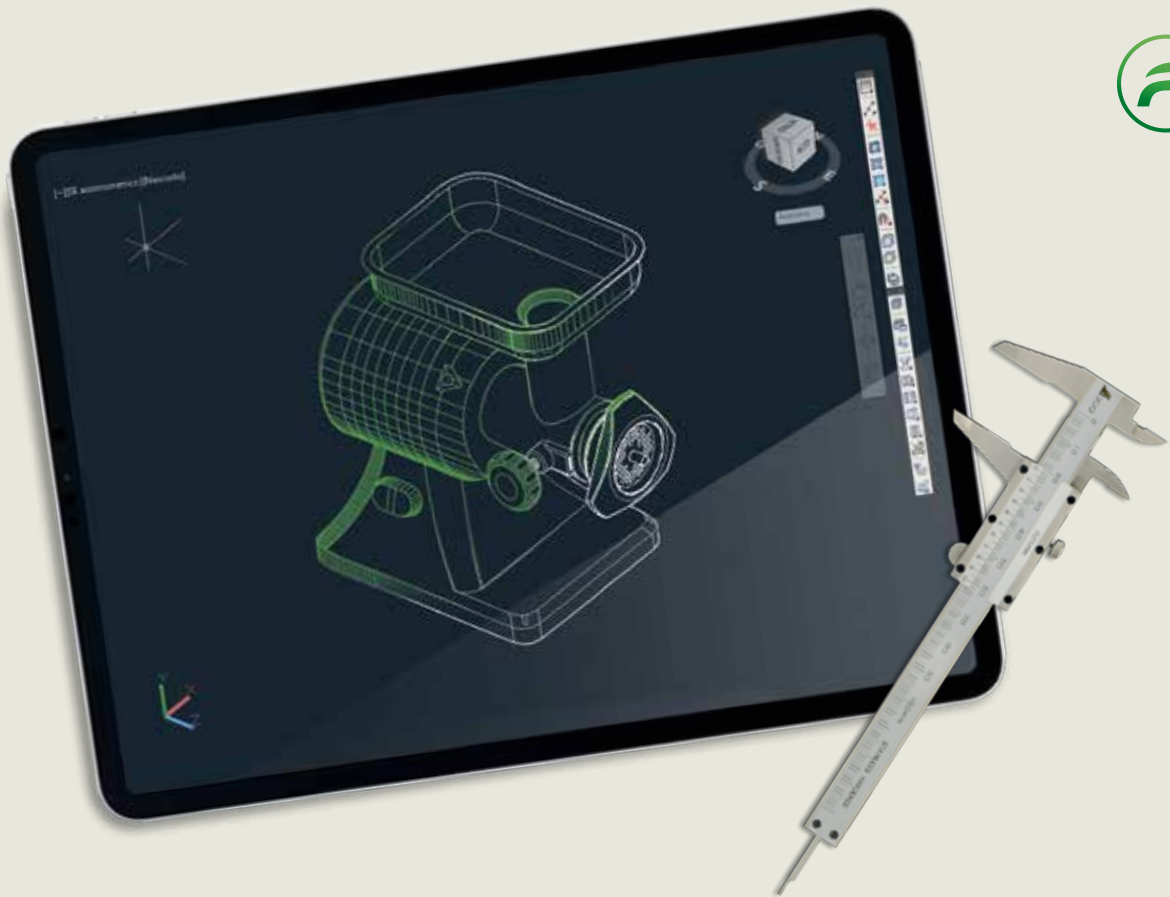

TRITACARNE MINCING MACHINES

Certificato di esame tipo
Type Examination Certificate

No. **IMQ 270**
Tritacarne / Mincing machines

Modelli / *Models*
TS 12, TI 12, TS 22, TI 22, TSK 22, TIK 22,
TS 32 ECO, TI 32 ECO, TI 12 R, TI 22 R, TI 32 R,
TI 22 RS, TI 32 RS



TRITACARNE GRATTUGIA MINCING MACHINES WITH GRATER MACHINES

Certificato di esame tipo
Type Examination Certificate

No. **IMQ 271**
Tritacarne con grattugia
Mincing machines with grater machines

Modelli / *Models*
TG 12, TGI 12, TG 22, TGI 22, TGK 12, TGK 12,
TGK 22, TGK 22



TRITACARNE E TRITACARNE GRATTUGIA MINCING MACHINES AND MINCING MACHINES WITH GRATER MACHINES

Certificato di esame tipo
Type Examination Certificate

No. **IMQ 272**
Tritacarne e tritacarne grattugia
Mincing machines and mincing
machines with grater machines

Modelli / *Models*
TS 8, TI 8, TG 8, TGI 8, GM



FRULLATORI E SBATTITORI BLENDERS AND WHISKS

Certificato di esame tipo
Type Examination Certificate

No. **IMQ 273**
Frullatori e sbattitori portatili
Hand-held blenders and whisks

Modelli / *Models*
250VF, 250VV, 300VV, 350VF, 350VV, 400VV, 450VF,
450VV, 500VV, 550VF, 550VV, 650VF, 650VV



GRATTUGIE GRATER MACHINE

Certificato di esame tipo
Type Examination Certificate

No. **IMQ 274**
Grattugia
Grater machine

Modelli / *Models*
GS, GSD, GSM, GI, GD, GG



PELAVERDURE VEGETABLE PEELERS

Certificato di esame tipo
Type Examination Certificate

No. **IMQ 275**
Pelaverdure
(pelapatate e puliscicozze)
Vegetable peelers
(potatoes peeling and mussels scraping)

Modelli / *Models*
5 Kg, 10 Kg, 18 Kg, 30 Kg



QUALITÀ, FIDUCIA E TECNOLOGIA,
LE NOSTRE RISORSE
IN QUESTI 70 ANNI

QUALITY, TRUST AND TECHNOLOGY
OUR RESOURCES IN THESE 70 YEARS





TRITACARNE • MEAT MINCERS

018 > 037



TRITACARNE GRATTUGIA • MEAT MINCER GRATERS

038 > 047



SERIE RETRÒ • RETRO MODELS

048 > 059



GRATTUGIE • GRATERS

060 > 067



MIXER AD IMMERSIONE • STICK BLENDERS

068 > 095



AFFETTATRICI • SLICING MACHINES

096 > 107



PREPARAZIONE DINAMICA • DYNAMIC PROCESSING

108 > 141



LAVORAZIONE CARNE • MEAT PROCESSING

142 > 165



LAVORAZIONE PASTA • KNEADING MACHINES

166 > 193



SNACK BAR • SNACK BAR

194 > 215



COTTURA • COOKING EQUIPMENT

216 > 257



REFRIGERATI • REFRIGERATED

258 > 280

INDICE

INDEX



P.22/23

TI8 TI12 TI22 TI32ECO



P.28/29

TSK12 TSK22 TIK12 TIK22



P.34/37

TS12 Unger TI12 Unger TS22 Unger TI22 Unger



P.40/41

TG8 TG12 TG22



P.44/45

TGK12 TGK22 TGIK12 TGIK22



P.50/51

TS8 R TG8 R GM R



P.54/55

250R 300R 350R



TS8 TS12 TS22 TS32ECO P.20/21



TI12 R TI22 RS TI22 R TI32 RS TI32 R TI32 R PRO P.24/26



TR22 TR32 P.30/31



TI12 R Unger TI22 R Unger TI32 RS Unger TI32 R Unger P.34/37



TGI8 TGI12 TGI22 P.42/43



APPLICAZIONI GRUPPI RICAMBI P. 46/47



TS12 R TG12 R GSR P.52/53

INDICE

INDEX



P.58/59 **275GR 300GR 330GR 350GR**



P.64/65 **GS GSD GSM GD**



P.72/76 **Miomix**



P.77/83 **350VV PRO 450VV PRO 550VV PRO 650VV PRO**



P.90/95 **250VF 250VV**



P.100/101 **275 Luxury 300 Luxury 330 Luxury 350 Luxury**



P.104/105 **330 Verticale Luxury 350 Verticale Luxury 370 Verticale Luxury**



220R 250R 275R P.56/57



GMB GMR GM P.62/63



GG HP2 GG HP4 P.65



350VF PRO 450VF PRO 550VF PRO 650VF PRO P.77/83



300VV 400VV 500VV P.84/89



220 ECO 250 ECO 250 275 ECO 300 ECO Base Piccola P.98/99



300 Verticale P.102/103

INDICE

INDEX

P.108/109



PP18kg **PP30kg**

P.114/117



LAVATARTUFI 18kg **30kg**

P.126/128



L4VV **L6VV** **L9VV**

P.136/137



TAGLIAMOZZARELLA

P.140/141



L8 ECO **L5 ECO** **L3 ECO** **L7 O** **L14 O** **L7 V** **L14 V**

P.146/149



1550 A **1550 V** **1830 A** **1830 V**

P.150/153



300 **350** **370**

P.106/107



PP5kg **PP10kg**

P.110/113



PC5kg **PC10kg** **PC18kg**

P.120/124



TAGLIAVERDURE ÉLITE **TAGLIAVERDURE ÉLITE PRO** **TV 25K**

P.130/134



L3

P.138/140



IMPASTACARNE

P.144/145



1650 A **1650 V** **1600 A** **1600 V** **1800 A** **1800 V**

P.150/153

INDICE

INDEX



P.154/155 **FSV32T FSV33IF FSV32IT**



FSV35IT FSV45IT FSV52IT P.156/157



P.158/160 **FSCV300 FSCV350 FSCV400**



200 **TERMO SIGILLATRICI** P.162/163



P.164/165 **FHA100 FHA400 FHA500**



MINI MEDIA MEDIA GRANDE **MACCHINE PASTA** P.168/171
tagliapasta tagliapasta



P.172/173 **5kg 5kg 5kg**



P.176/177 **8kg 17kg 25kg 37kg 42kg**



8kg 17kg 25kg 37kg 42kg P.174/175



8kg 18kg 25kg 38kg P.178/179



P.180/181 **18kg 25kg 38kg**



P.183 **10kg 20kg 30kg 40kg**



BAKER PM BAKER PK P.182



10kg 20kg 30kg KitchenAid P.184/187

INDICE

INDEX

P.190/191



MANUALE ELETTRICA

P.196/199



MF4 MF4D MSE MSP MSP2

P. 200/202



MTQ MTFIVE MT5

P. 206/209



MTG6 MSG100 MG13 MG20 MG50

P.214



FPM

P.222/223



MFR40 MFR240 MFR80 MFR280

P.226/227



MFR12R MFR212R MFR12M MFR212M



L30H L40H L30I L40I L40P

P.188/189



320 400 500

P.192/193



MT1 MT1D MT1I MT1DI

P.200/202



MCF100 FCF100 FES100D FES102 DOMESTICO FES104 PROFESSION

P. 203/205



CS CD FMC6 FMX

P.210/213



RONER 25 ECO

P.218



MFR80R MFR280R MFR10R MFR210R

P.224/225

INDICE

INDEX



P.228/230 **FFM100S FFM101G FFM102U FFM103C FFM103PF FFM105C**



P.236/237 **B1V B1+1V B7 B7+7**



P.238/239 **B8 B8+8 B9 B9+9**



P.242/243 **Q4 Q6 Q12 Q18**



P.246/247 **CPS40 CPD**



P.251 **PIND01 PIND02 PIND02 WOK**



P.260/261 **PFT1L PFT2L PFT3L**



FFDU4 FFDU5 FFDU6 FFDU7 FFDU10 P.232/233



DECS11M P.234



FS40 FS70 FS60 P.240/241



MTP100 MTP101 MRT600 MRT700 P.244/245



PSINGS PCORTS PDR3000S PSING PCORT PDR3000 P.248/249



UPM UPD P.258/259

INDICE

INDEX



P.256/257

PFTM PFTD



P.264/266

FFR700TN FFR700BT FFR1400TN FFR1400BT



FABB23 FABB3 FABB5 FABB10

P.260/263



FTR2TN FTR3TN FTR4TN

P.268/270



P.271

FBR2100TN FBR3100TN



P.273

FV12033 FV15033 FV18033 FV20033



FV15033 FBR2600TN FV20033 FBR2610TN FV20033 FBR3600TN

P.272



FBL107 FBL127 FBL147 FBL157 FBL167 FBL187 FBL207

P.274



P.275

FBL107A FBL127A FBL147A FBL157A FBL167A FBL187A FBL207A



FBA107 FBA127 FBA147 FBA157 FBA167 FBA187 FBA207

P.276

P.277

FBA107A FBA127A FBA147A FBA157A FBLA167A FBA187A FBA207A



FPAS60 FPAS80 FPAS100 FPAS120 FPAS140 FPAS160 FPAS180 FPAS200

P.278



P.279

FCRS280 FCRS2100 FCRS380 FCRS3100



FLM40

P.280



IERI, OGGI E DOMANI
LA TUA CERTEZZA IN CUCINA

INDUSTRY-LEADING TECHNOLOGY
FOR FOODSERVICE AND FOOD RETAIL
PROFESSIONALS WORLDWIDE



TRITACARNE
meat mincer

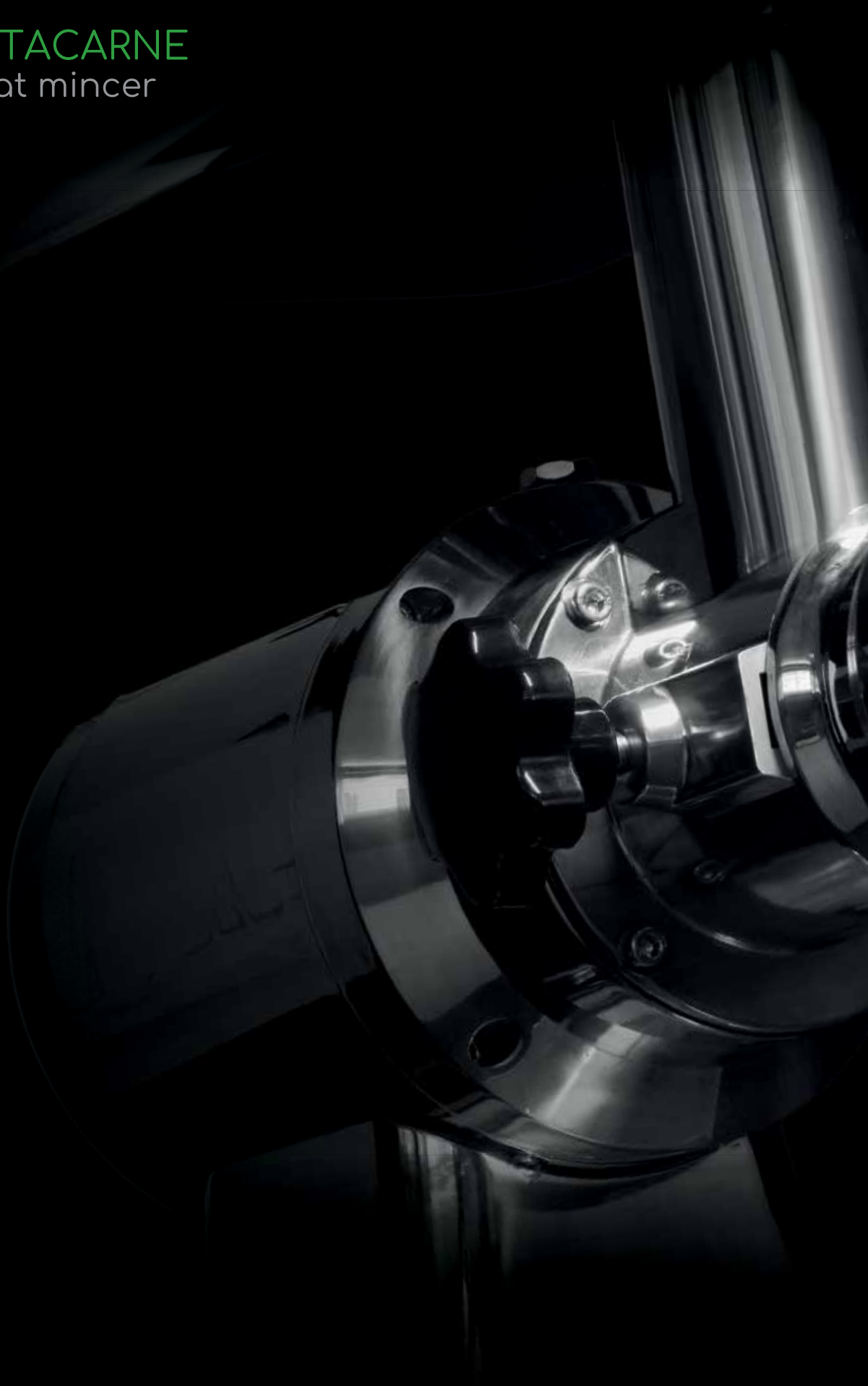

FORZA E AFFIDABILITÀ:
LA SCELTA DEI PROFESSIONISTI

STRENGTH AND RELIABILITY:
THE PROFESSIONAL'S CHOICE



SERIE TS
TS MODELS

SERIE TI
TI MODELS

SERIE TI R
TI R MODELS

SERIE UNIKO
UNIKO MODELS

REFRIGERATI
REFRIGERATED

SERIE UNGER
UNGER MODELS





TRITACARNE SERIE TS

MEAT MINCERS

TS MODELS

- Macchinario per uso professionale • Costruito in lega di alluminio pressofuso lucidato • Elegante fascia in acciaio inossidabile sulla carcassa motore • Ingranaggi elicoidali in acciaio temperato a bagno d'olio • Motore asincrono ventilato con termica di protezione • Gruppo macinazione carne: Ghisa / Alluminio / Acciaio Inox • Trafile auto affilanti in acciaio inox di serie • Tramoggia e piatto raccolta in acciaio inox • Pestello in ABS • Comandi a 24 volt • Set per insaccare (a richiesta) • Inversione di marcia (a richiesta) • Norme CE • Fabbriato in Italia

- Professional equipment • Structured in polished pressure die cast aluminium alloy • Elegant stainless steel motor cover band • Oil immersed gears made from hardened steel • Ventilated asynchronous motor with thermal protection included • Easy-removable mincing unit available in: Electroless nickel plated cast iron / Anodized aluminium / Aisi 304 stainless steel • Stainless steel self-sharpening draw-plates included • Stainless steel tray and hopper • ABS pestle • 24 volt controls • Gear inversion option available on demand • Sausage filling kit available on demand • CE approved • Proudly Made in Italy



Gruppi di macinazione - Mincing Groups

	Inox - S/Steel	Alluminio - Aluminium	Ghisa - Cast Iron
TS 8	●	●	●
TS 12	●	●	●
TS 22	●	●	●
TS 32ECO	●	●	●

	Alimentazione Power supply (Volt/Hz)	Potenza Motor power (Kwatt/Hp)	Giri/m coclea Screw revolution (RPM)	Produzione oraria Production per hour (kg/h)	Bocca inserimento carne Inlet (mm)	Piastra in dotazione Standard plate (mm)
TS 8	230/50	0,38 (0,50)	80	15	ø 52	ø 6
TS 12	230/50 230-400/50	0,75 (1,00)	200	150/200		
TS 22		1,10 (1,50)	140	300		
TS 32 ECO		1,50 (2,00)	140	400		

TS 8



Bocca d'uscita
Barrel (mm)
Ø 60



Peso netto
Net weight (kg)
9,0 kg



Dimensioni prodotto
Product dimension (mm)
D. 260 / B. 270 / H. 360



TS 12



Bocca d'uscita
Barrel (mm)
Ø 70



Peso netto (mono/trifase)
Net weight single/three phase (kg)
19,0 / 16,0 kg



Dimensioni prodotto
Product dimension (mm)
D. 220 / B. 370 / H. 440



TS 22



Bocca d'uscita
Barrel (mm)
Ø 82



Peso netto (mono/trifase)
Net weight single/three phase (kg)
24,0 / 22,0 kg



Dimensioni prodotto
Product dimension (mm)
D. 240 / B. 440 / H. 510



TS 32 ECO



Bocca d'uscita
Barrel (mm)
Ø 98



Peso netto (mono/trifase)
Net weight single/three phase (kg)
33,0 / 31,0 kg



Dimensioni prodotto
Product dimension (mm)
D. 240 / B. 500 / H. 510



TS 8 230V monofase *single phase*
codice prodotto *product code*

TS 12 230/400V trifase *three phase*
codice prodotto *product code*

TS 12 230V monofase *single phase*
codice prodotto *product code*

TS 22 230/400V trifase *three phase*
codice prodotto *product code*

TS 22 230V monofase *single phase*
codice prodotto *product code*

TS 32 ECO 230/400V trifase *three phase*
codice prodotto *product code*

TS 32 ECO 230V monofase *single phase*
codice prodotto *product code*

FINV inversione di marcia di serie su TS32 ECO CE - non disponibile per TS8 *gear reverse option standard on TS32 ECO CE, not available for TS8*

	NORME CE / CE APPROVED		SENZA NORME CE / NON CE APPROVED	
	Gruppo Macinazione		Mincing group	
	Alluminio Alimentare	Acciaio Inox	Food Aluminum	Stainless Steel
	FTSM101	FTSM126	FTSM101E	FTSM126E
	Gruppo Macinazione		Mincing group	
	Ghisa	Acciaio Inox	Cast Iron	Stainless Steel
	FTS106	FTS126	FTS106E	FTS126E
	FTS107	FTS127	FTS107E	FTS127E
	FTS116	FTS136	FTS116E	FTS136E
	FTS117	FTS137	FTS117E	FTS137E
	FTS146	FTS138	FTS146E	FTS138E
	FTS147	FTS139	FTS147E	FTS139E
	su richiesta / on request		di serie / included	

• I macchinari senza norme CE sono destinati ai paesi fuori dalla Comunità Europea / *Not suitable for EC countries* • Le illustrazioni sono riferite ai modelli CE / *Pictures refer to CE approved models*



TRITACARNE SERIE TI MEAT MINCERS TI MODELS

- Macchinario per uso professionale • Struttura in acciaio inossidabile lucidato • Ingranaggi elicoidali in acciaio temperato a bagno d'olio • Motore asincrono ventilato con termica di protezione • Gruppo macinazione carne: Ghisa / Alluminio / Acciaio Inox • Trafile auto affilanti in acciaio inox di serie • Tramoggia e piatto raccolta in acciaio inox • Pestello in ABS • Comandi a 24 volt • Set per insaccare (a richiesta) • Inversione di marcia (a richiesta) • Norme CE • Fabbricato in Italia

- Professional equipment • Structured in polished stainless steel • Oil immersed steel gears • Ventilated asynchronous motor with thermal protection included • Easy-removable mincing unit available in: Electroless nickel plated cast iron / Anodized aluminium / AISI 304 stainless steel • Stainless steel self-sharpening draw-plates included • Stainless steel tray and hopper • ABS pestle • 24 volt controls • Sausage filling kit available on demand • Gear inversion option available on demand • CE approved • Proudly Made in Italy



Gruppi di macinazione - Mincing Groups

	Inox - S/Steel	Alluminio - Aluminium	Ghisa - Cast Iron
TI 8	●	●	●
TI 12	●	●	●
TI 22	●	●	●
TI 32ECO	●	●	●

	Alimentazione Power supply (Volt/Hz)	Potenza Motor power (Kwatt/Hp)	Giri/m coclea Screw revolution (RPM)	Produzione oraria Production per hour (kg/h)	Bocca inserimento carne Inlet (mm)	Piastra in dotazione Standard plate (mm)
TI 8	230/50	0,38 (0,50)	80	15	ø 52	ø 6
TI 12	230/50 230-400/50	0,75 (1,00)	200	150/200		
TI 22		1,10 (1,50)	140	300		
TI 32 ECO		1,50 (2,00)	140	400		

TI 8



Bocca d'uscita
Barrel (mm)
Ø 60



Peso netto
Net weight (kg)
10,0 kg



Dimensioni prodotto
Product dimension (mm)
D. 280 / B. 270 / H. 350



TI 12



Bocca d'uscita
Barrel (mm)
Ø 70



Peso netto (mono/trifase)
Net weight single/three phase (kg)
22,0 / 19,0 kg



Dimensioni prodotto
Product dimension (mm)
D. 215 / B. 430 / H. 440



TI 22



Bocca d'uscita
Barrel (mm)
Ø 82



Peso netto (mono/trifase)
Net weight single/three phase (kg)
25,0 / 22,0 kg



Dimensioni prodotto
Product dimension (mm)
D. 215 / B. 440 / H. 440



TI 32 ECO



Bocca d'uscita
Barrel (mm)
Ø 98



Peso netto (mono/trifase)
Net weight single/three phase (kg)
36,0 / 35,0 kg



Dimensioni prodotto
Product dimension (mm)
D. 225 / B. 500 / H. 510



	NORME CE / CE APPROVED		SENZA NORME CE / NON CE APPROVED	
	Gruppo Macinazione		Mincing group	
	Alluminio Alimentare	Acciaio Inox	Food Aluminum	Stainless Steel
TI 8 230V monofase <i>single phase</i> codice prodotto <i>product code</i>	FTSM1101	FTSM127	FTSM1101E	FTSM127E
	Gruppo Macinazione		Mincing group	
	Ghisa	Acciaio Inox	Cast Iron	Stainless Steel
TI 12 230/400V trifase <i>three phase</i> codice prodotto <i>product code</i>	FTI106	FTI126	FTI106E	FTI126E
TI 12 230V monofase <i>single phase</i> codice prodotto <i>product code</i>	FTI107	FTI127	FTI107E	FTI127E
TI 22 230/400V trifase <i>three phase</i> codice prodotto <i>product code</i>	FTI116	FTI136	FTI116E	FTI136E
TI 22 230V monofase <i>single phase</i> codice prodotto <i>product code</i>	FTI117	FTI137	FTI117E	FTI137E
TI 32 ECO 230/400V trifase <i>three phase</i> codice prodotto <i>product code</i>	FTI146	FTI156	FTI146E	FTI156E
TI 32 ECO 230V monofase <i>single phase</i> codice prodotto <i>product code</i>	FTI147	FTI157	FTI147E	FTI157E
FINV inversione di marcia di serie su TI32 ECO CE - non disponibile per TI8 <i>gear reverse option standard on TI32 ECO CE, not available for TI8</i>	su richiesta / on request		di serie / included	

• I macchinari senza norme CE sono destinati ai paesi fuori dalla Comunità Europea / *Not suitable for EC countries* • Le illustrazioni sono riferite ai modelli CE / *Pictures refer to CE approved models*



TRITACARNE SERIE TI R MEAT MINCERS TI R MODELS

• Macchinario per uso professionale • Struttura in acciaio inossidabile lucidato • Ingranaggi elicoidali in acciaio temperato a bagno d'olio • Motore asincrono ventilato con termica di protezione • Gruppo macinazione carne: Ghisa / Alluminio / Acciaio Inox • Trafile auto affilanti in acciaio inox di serie • Tramoggia e piatto raccolta in acciaio inox • Pestello in ABS • Comandi a 24 volt • Set per insaccare (a richiesta) • Inversione di marcia (a richiesta) • Norme CE • Fabbriato in Italia

• Professional equipment • Structured in polished stainless steel • Oil immersed steel gears • Ventilated asynchronous motor with thermal protection included • Easy-removable mincing unit available in: Electroless nickel plated cast iron / Anodized aluminium / AISI 304 stainless steel • Stainless steel self-sharpening draw-plates included • Stainless steel tray and hopper • ABS pestle • 24 volt controls • Sausage filling kit available on demand • Gear inversion option available on demand • CE approved • Proudly Made in Italy



TI 12R



Bocca d'uscita
Barrel (mm)
Ø 70



Peso netto
Net weight (kg)
26,0 kg



Dimensioni prodotto
Product dimension (mm)
D. 260 / B. 400 / H. 490



TI 22 RS



Bocca d'uscita
Barrel (mm)
Ø 82



Peso netto (mono/trifase)
Net weight single/three phase (kg)
35,0 / 34,0 kg



Dimensioni prodotto
Product dimension (mm)
D. 260 / B. 435 / H. 525



TI 22 R



Bocca d'uscita
Barrel (mm)
Ø 82



Peso netto (mono/trifase)
Net weight single/three phase (kg)
32,0 / 32,0 kg



Dimensioni prodotto
Product dimension (mm)
D. 260 / B. 450 / H. 530



TI 32 RS



Bocca d'uscita
Barrel (mm)
Ø 98



Peso netto (mono/trifase)
Net weight single/three phase (kg)
40,0 / 40,0 kg



Dimensioni prodotto
Product dimension (mm)
D. 260 / B. 510 / H. 525



TI 32 R



Bocca d'uscita
Barrel (mm)
Ø 98



Peso netto (mono/trifase)
Net weight single/three phase (kg)
52,0 / 46,0 kg



Dimensioni prodotto
Product dimension (mm)
D. 300 / B. 475 / H. 560



TI 32 R^{PRO}



Bocca d'uscita
Barrel (mm)
Ø 98



Peso netto
Net weight (kg)
50,0 kg



Dimensioni prodotto
Product dimension (mm)
D. 295 / B. 545 / H. 550



Gruppi di macinazione - Mincing Groups			
	Inox - S/Steel	Alluminio - Aluminium	Ghisa - Cast Iron
TI 12 R	●	●	●
TI 22 RS	●	●	●
TI 22 R	●	●	●
TI 32 RS	●	●	●

Gruppi di macinazione - Mincing Groups			
	Inox - S/Steel	Alluminio - Aluminium	Ghisa - Cast Iron
TI 32 R	●	●	●
TI 32 R^{PRO}	●	●	●

	Alimentazione Power supply (Volt/Hz)	Potenza Motor power (Kwatt/Hp)	Giri/m coclea Screw revolution (RPM)	Produzione oraria Production per hour (kg/h)	Bocca inserimento carne Inlet (mm)	Piastra in dotazione Standard plate (mm)
TI 12 R	230/50 230-400/50	1,10 (1,50)	140	250	∅ 52	∅6
TI 22 R		1,50 (2,00)		350/400	∅ 52	
TI 22 RS		1,50 (2,00)		400/500	∅ 52 / ∅ 76	
TI 32 RS		1,60 (2,20)		500	∅ 52 / ∅ 76	
TI 32 R		2,20 (3,00)		600	∅ 52 / ∅ 76	
TI 32 R^{PRO}	230-400/50	2,20 (3,00)		600	∅ 76	

	NORME CE / CE APPROVED		SENZA NORME CE / NON CE APPROVED	
	Gruppo Macinazione		Mincing group	
	Ghisa Alimentare	Acciaio Inox	Food Grade Cast Iron	Stainless Steel
TI 12 R 230/400V trifase three phase codice prodotto product code	FTI106R	FTI126R	FTI106RE	FTI126RE
TI 12 R 230V monofase single phase codice prodotto product code	FTI107R	FTI127R	FTI107RE	FTI127RE
TI 22 RS 230/400V trifase three phase codice prodotto product code		FTI136RS		FTI136RSE Inlet ∅ 76mm
TI 22 RS 230V monofase single phase codice prodotto product code		FTI137RS		FTI137RSE Inlet ∅ 76mm
TI 22 R 230/400V trifase three phase codice prodotto product code	FTI116R	FTI136R	FTI116RE	FTI136RE
TI 22 R 230V monofase single phase codice prodotto product code	FTI117R	FTI137R	FTI117RE	FTI137RE
TI 32 RS 230/400V trifase three phase codice prodotto product code		FTI138RS		FTI138RSE Inlet ∅ 76mm
TI 32 RS 230V monofase single phase codice prodotto product code		FTI139RS		FTI139RSE Inlet ∅ 76mm
TI 32 R 230/400V trifase three phase codice prodotto product code		FTI138R		FTI138RE Inlet ∅ 76mm
TI 32 R 230V monofase single phase codice prodotto product code		FTI139R		FTI139RE Inlet ∅ 76mm
TI 32 R PRO 230/400V trifase three phase codice prodotto product code		FTI138RP		
FINV inversione di marcia di serie nei modelli TI32R - TI32R PRO gear reverse option standard on TI32R - TI32R PRO	su richiesta / on request		di serie / included	

• I macchinari senza norme CE sono destinati ai paesi fuori dalla Comunità Europea / Not suitable for EC countries • Le illustrazioni sono riferite ai modelli CE / Pictures refer to CE approved models





TRITACARNE SERIE UNIKO MEAT MINCERS UNIKO

- Macchinario per uso professionale • Corpo in lega di alluminio pressofuso • Sistema di riduzione ad ingranaggi elicoidali a bagno d'olio • Robusto motore asincrono di produzione nazionale • Termica di protezione
- Gruppo macinazione carne: Acciaio Inox • Trafilte auto affilanti in acciaio inox di serie • Tramoggia e piatto raccolta prodotto in acciaio inox • Pestello in ABS • Comandi a 24 volt • Disponibile set per insaccare (a richiesta) • Disponibile con inversione di marcia (a richiesta) • Norme CE • Fabbricato in Italia

- Professional equipment • Pressure die cast aluminium alloy cover casing • Speed reducer with oil immersed gears • Heavy duty Italian make asynchronous motor • Thermal protection • AISI 304 stainless steel easy-removable "ENTERPRISE" mincing unit • Stainless steel self-sharpening draw-plates included • Stainless steel tray and hopper • ABS pestle • 24 volt controls • Sausage filling kit available on demand • Gear inversion option available on demand • CE approved • Proudly Made in Italy



Gruppo macinazione inox completamente smontabile
Completely removable stainless steel mincing group

Gruppi di macinazione - Mincing Groups

	Inox - S/Steel
TSK 12	•
TSK 22	•
TIK 12	•
TIK 22	•

	Alimentazione Power supply (Volt/Hz)	Potenza Motor power (Kwatt/Hp)	Giri/m coclea Screw revolution (RPM)	Produzione oraria Production per hour (kg/h)	Bocca inserimento carne Inlet (mm)	Piastra in dotazione Standard plate (mm)
TSK 12	230/50 230-400/50	0,75 (1,00)	200	150/200	ø 52	ø 6
TSK 22		1,10 (1,50)	140	300		
TIK 12		0,75 (1,00)	200	150/200		
TIK 22		1,10 (1,50)	140	300		

TSK 12



Bocca d'uscita
Barrel (mm)
Ø 70



Peso netto (mono/trifase)
Net weight single/three phase (kg)
21,0 / 18,0 kg



Dimensioni prodotto
Product dimension (mm)
D. 220 / B. 440 / H. 440



TSK 22



Bocca d'uscita
Barrel (mm)
Ø 82



Peso netto (mono/trifase)
Net weight single/three phase (kg)
25,0 / 23,0 kg



Dimensioni prodotto
Product dimension (mm)
D. 240 / B. 490 / H. 500



TIK 12



Bocca d'uscita
Barrel (mm)
Ø 70



Peso netto (mono/trifase)
Net weight single/three phase (kg)
24,0 / 23,0 kg



Dimensioni prodotto
Product dimension (mm)
D. 215 / B. 480 / H. 430



TIK 22



Bocca d'uscita
Barrel (mm)
Ø 82



Peso netto (mono/trifase)
Net weight single/three phase (kg)
27,0 / 25,0 kg



Dimensioni prodotto
Product dimension (mm)
D. 215 / B. 490 / H. 430



	NORME CE / CE APPROVED	SENZA NORME CE / NON CE APPROVED
	Gruppo Macinazione	Mincing group
	Acciaio Inox	Stainless Steel
TSK 12 230/400V trifase three phase codice prodotto product code	FTSK126	FTSK126E
TSK 12 230V monofase single phase codice prodotto product code	FTSK127	FTSK127E
TSK 22 230/400V trifase three phase codice prodotto product code	FTSK136	FTSK136E
TSK 22 230V monofase single phase codice prodotto product code	FTSK137	FTSK137E
TIK 12 230/400V trifase three phase codice prodotto product code	FTIK126	FTIK126E
TIK 12 230V monofase single phase codice prodotto product code	FTIK127	FTIK127E
TIK 22 230/400V trifase three phase codice prodotto product code	FTIK136	FTIK136E
TIK 22 230V monofase single phase codice prodotto product code	FTIK137	FTIK137E
FINV inversione di marcia gear reverse option	su richiesta / on request	di serie / included



TRITACARNE REFRIGERATO

REFRIGERATED MEAT MINCER

- Macchinario per uso professionale • Monoblocco in acciaio inossidabile
- Motore asincrono ventilato e motoriduttore a bagno d'olio • Gruppo macinazione carne: Acciaio Inox • Tramoggia refrigerata • Coperchio in plexiglass trasparente • Gas refrigerante R 134a - 80gr • Temperatura -2 +4, regolabile tramite termostato • Trasmissione a ingranaggi • Termica di protezione • Facile da pulire • Disponibile con inversione di marcia (a richiesta) • Norme CE • Fabbriato in Italia

- Professional equipment • Stainless steel cover casing • Ventilated and permanently lubricated geared electrical motor • Cutting unit and knob completely in stainless steel • Refrigerated hopper • Plexyglass transparent lid • Constant cooling by hermetic compressor with R 134a -80 gr Gas • Homogeneous temperature during all cutting process, adjustable from -2° to +4°C • Stainless steel drive gears • Thermal overload protection included • Entirely detachable for easy cleaning • Gear inversion option available on demand • CE approved • Proudly Made in Italy



TR 22



Bocca d'uscita
Barrel (mm)
Ø 82



Peso netto (mono/trifase)
Net weight single/three phase (kg)
43,0 / 43,0 kg



Dimensioni prodotto
Product dimension (mm)
D. 270 / B. 410 / H. 545



TR 32



Bocca d'uscita
Barrel (mm)
Ø 98



Peso netto (mono/trifase)
Net weight single/three phase (kg)
56,0 / 56,0 kg



Dimensioni prodotto
Product dimension (mm)
D. 350 / B. 530 / H. 555



Gruppi di macinazione - Mincing Groups

	Inox - S/Steel	Alluminio - Aluminium	Ghisa - Cast Iron
TR 22	●	●	●
TR 32	●	●	●

	Alimentazione Power supply (Volt/Hz)	Potenza Motor power (Kwatt/Hp)	Giri/m coclea Screw revolution (RPM)	Produzione oraria Production per hour (kg/h)	Bocca inserimento carne Inlet (mm)	Piastra in dotazione Standard plate (mm)
TR 22	230/50	0,90 (1,20)	120	280/300	Ø 52	Ø 6
TR 32	230-400/50	1,85 (1,50)		450		

NORME CE / CE APPROVED

Gruppo Macinazione

Acciaio Inox

FTR100INV

FTR100MINV

FTR200INV

FTR200MINV

TR 22 230/400V trifase three phase
codice prodotto product code

TR 22 230V monofase single phase
codice prodotto product code

TR 32 230/400V trifase three phase
codice prodotto product code

TR 32 230V monofase single phase
codice prodotto product code

GRUPPO CARNE ENTERPRISE

ENTERPRISE MINCING ASSEMBLY



	Alluminio Alimentare Food Grade Aluminium	Ghisa Alimentare Food Grade Cast Iron	Acciaio Inox Stainless Steel
Mod. 8 Bocca, coclea con perno, volantino, n° 1 piastra, coltello <i>Mouth, screw, handwheel, n° 1 plate, knife</i> codice prodotto <i>product code</i>	FOTM8A		FOTM8I
Mod. 12 Bocca, coclea con perno, volantino, n° 1 piastra, coltello <i>Mouth, screw, handwheel, n° 1 plate, knife</i> codice prodotto <i>product code</i>	FOTM12A	FOTM12G	FOTM12I
Mod. 22 Bocca, coclea con perno, volantino, n° 1 piastra, coltello <i>Mouth, screw, handwheel, n° 1 plate, knife</i> codice prodotto <i>product code</i>	FOTM22A	FOTM22G	FOTM22I
Mod. 32 ECO Bocca, coclea con perno, volantino, n° 1 piastra, coltello <i>Mouth, screw, handwheel, n° 1 plate, knife</i> codice prodotto <i>product code</i>		FOTM32G	FOTM32IE
Mod. 22 RS Bocca, coclea con perno, volantino, n° 1 piastra, coltello <i>Mouth, screw, handwheel, n° 1 plate, knife</i> codice prodotto <i>product code</i>			FOTM22IR
Mod. 32 R-RS Bocca, coclea con perno, volantino, n° 1 piastra, coltello <i>Mouth, screw, handwheel, n° 1 plate, knife</i> codice prodotto <i>product code</i>			FOTM32IR

I RICAMBI SONO ADATTI SIA PER MACCHINARI **CE** CHE PER MACCHINARI **NON CE** - ACCESSORIES ARE SUITABLE FOR **CE** AND **NON CE** APPROVED MODEL

RICAMBI PER TRITACARNE ENTERPRISE

SPARE PARTS FOR ENTERPRISE MINCER



Piastra e coltelli Acciaio Inox
Stainless Steel plates and knives

	Modello 8	Modello 12	Modello 22	Modello 32
Piastra ø 2 mm Plate ø 2 mm codice prodotto <i>product code</i>	F0403	F0406	F0409	F0412
Piastra ø 3 mm Plate ø 3 mm codice prodotto <i>product code</i>	F0404	F0407	F0410	F0413
Piastra ø 3,5 mm Plate ø 3,5 mm codice prodotto <i>product code</i>	F0405	F0408	F0411	F0414
Piastra ø 4,5 mm Plate ø 4,5 mm codice prodotto <i>product code</i>	F2045	F2131	F2219	F0502
Piastra ø 6 mm Plate ø 6 mm codice prodotto <i>product code</i>	F3134	F3136	F3138	F3140
Piastra ø 8 mm Plate ø 8 mm codice prodotto <i>product code</i>	F3135	F3137	F3139	F3141
Coltello Knife codice prodotto <i>product code</i>	F2044	F2130	F2218	F0503

IMBUTI PER INSACCARE

SAUSAGE FILLING FUNNELS



Set 3 imbusti in Moplen per insaccare Mod. 8 - Foro imbusti mm 15/20/25 Sausage filling kit Mod. 08 (3 pcs kit) - Funnel diam mm 15/20/25	F0163/8
Set 3 imbusti in Moplen per insaccare Mod. 12 - Foro imbusti mm 15/20/25 Sausage filling kit Mod. 12 (3 pcs kit) - Funnel diam mm 15/20/25	F0163/12
Set 3 imbusti in Moplen per insaccare Mod. 22 - Foro imbusti mm 15/20/25 Sausage filling kit Mod. 22 (3 pcs kit) - Funnel diam mm 15/20/25	F0163/22
Set 3 imbusti in Moplen per insaccare Mod. 32 - Foro imbusti mm 15/20/25 Sausage filling kit Mod. 32 (3 pcs kit) - Funnel diam mm 15/20/25	F0163/32
Anello per insaccare Mod. 8 Ring for funnels Mod. 8	F2939
Anello per insaccare Mod. 12 Ring for funnels Mod. 12	F2227
Anello per insaccare Mod. 22 Ring for funnels Mod. 22	F2228
Anello per insaccare Mod. 32 Ring for funnels Mod. 32	F3507

APPLICAZIONI SOLO PER TRITACARNE O TRITACARNE GRATTUGIA MOD. 12 O 22 **ESCLUSO UNIKO** • AVAILABLE FOR MEAT MINCER AND COMBO MEAT MINCER AND GRATER MOD. 12 OR 22 ONLY - **NOT SUITABLE FOR UNIKO MODELS** • TUTTE LE APPLICAZIONI SONO DA INTENDERSI SENZA MACCHINARIO - DEVICES PRICES ARE NOT INCLUSIVE OF MEAT MINCER • LE APPLICAZIONI SONO ADATTE SIA PER MACCHINARI **CE** CHE PER MACCHINARI **NON CE** - DEVICES ARE SUITABLE FOR **CE** AND **NON CE** APPROVED MODEL

APPLICAZIONE PASSAPOMODORO

TOMATO SQUEEZER DEVICE



Mod. 12 Applicazioni per il nostro tritacarne Mod. 12 Device for model 12

FPP100

Mod. 22 Applicazioni per il nostro tritacarne Mod. 22 Device for model 22

FPP101

APPLICAZIONE PASSAPUREA

POTATO MASHER DEVICE



Mod. 12 Applicazioni per il nostro tritacarne Mod. 12 Device for model 12

FPP102

Mod. 22 Applicazioni per il nostro tritacarne Mod. 22 Device for model 22

FPP103





TRITACARNE SERIE UNGER UNGER MEAT MINCERS

- Macchinario per uso professionale • Struttura in acciaio inossidabile lucidato • Ingranaggi elicoidali in acciaio temperato a bagno d'olio • Motore asincrono ventilato con termica di protezione • Gruppo macinazione carne: Ghisa / Alluminio / Acciaio Inox • Trafilte auto affilanti in acciaio inox di serie • Tramoggia e piatto raccolta in acciaio inox • Pestello in ABS • Comandi a 24 volt • Set per insaccare (a richiesta) • Inversione di marcia (a richiesta) • Norme CE • Fabbricato in Italia

- Professional equipment • Structured in polished stainless steel • Oil immersed steel gears • Ventilated asynchronous motor with thermal protection included • Easy-removable mincing unit available in: Electroless nickel plated cast iron / Anodized aluminium / AISI 304 stainless steel • Stainless steel self-sharpening draw-plates included • Stainless steel tray and hopper • ABS pestle • 24 volt controls • Sausage filling kit available on demand • Gear inversion option available on demand • CE approved • Proudly Made in Italy

IL SISTEMA UNGER MONTA COLTELLI A DOPPIO TAGLIO E UNA SERIE DI PIASTRE CON DIFFERENTI FORI IN GRADO DI RENDERE LE CARNI LAVORATE UN IMPASTO OMOGENEO

THE UNGER SYSTEM MOUNTS DOUBLE EDGED KNIVES AND A SERIES OF PLATES WITH DIFFERENT HOLES CAPABLE OF MAKING THE PROCESSED MEATS A HOMOGENEOUS MIXTURE



Gruppi di macinazione - Mincing Groups

	Inox S/Steel	Alluminio Aluminium	Ghisa Cast Iron
TS TI 12 / TS TI 22	●	●	●
TI 12 R / TI 22 R	●	●	●
TI 32 R / TI 32 RS	●	●	●
TI 32 R^{PRO} UNGER	●	●	●

TS 12 UNGER



Bocca d'uscita
Barrel (mm)
Ø 70



Peso netto (mono/trifase)
Net weight single/three phase (kg)
23,0 / 21,0 kg



Dimensioni prodotto
Product dimension (mm)
D. 215 / B. 480 / H. 430



TI 12 UNGER



Bocca d'uscita
Barrel (mm)
Ø 70



Peso netto (mono/trifase)
Net weight single/three phase (kg)
24,0 / 22,0 kg



Dimensioni prodotto
Product dimension (mm)
D. 215 / B. 490 / H. 430



TS 22 UNGER



Bocca d'uscita
Barrel (mm)
Ø 82



Peso netto (mono/trifase)
Net weight single/three phase (kg)
25,0 / 23,0 kg



Dimensioni prodotto
Product dimension (mm)
D. 220 / B. 440 / H. 440



TI 22 UNGER



Bocca d'uscita
Barrel (mm)
Ø 82



Peso netto (mono/trifase)
Net weight single/three phase (kg)
26,0 / 24,0 kg



Dimensioni prodotto
Product dimension (mm)
D. 240 / B. 490 / H. 500



TI 12 R UNGER



Bocca d'uscita
Barrel (mm)
Ø 70



Peso netto (mono/trifase)
Net weight single/three phase (kg)
27,0 / 27,0 kg



Dimensioni prodotto
Product dimension (mm)
D. 215 / B. 480 / H. 430



TI 22 R UNGER



Bocca d'uscita
Barrel (mm)
Ø 82



Peso netto (mono/trifase)
Net weight single/three phase (kg)
33,0 / 33,0 kg



Dimensioni prodotto
Product dimension (mm)
D. 215 / B. 490 / H. 430



TI 32 RS UNGER



Bocca d'uscita
Barrel (mm)
Ø 98



Peso netto (mono/trifase)
Net weight single/three phase (kg)
40,0 / 40,0 kg



Dimensioni prodotto
Product dimension (mm)
D. 215 / B. 480 / H. 430



TI 32 R UNGER



Bocca d'uscita
Barrel (mm)
Ø 98



Peso netto (mono/trifase)
Net weight single/three phase (kg)
54,0 / 48,0 kg



Dimensioni prodotto
Product dimension (mm)
D. 215 / B. 490 / H. 430



TI 32 R^{PRO} UNGER



Bocca d'uscita
Barrel (mm)
Ø 98



Peso netto
Net weight (kg)
50,0 kg



Dimensioni prodotto
Product dimension (mm)
D. 295 / B. 545 / H. 550



	Alimentazione Power supply (Volt/Hz)	Potenza Motor power (Kwatt/Hp)	Giri/m coclea Screw revolution (RPM)	Produzione oraria Production per hour (kg/h)	Bocca inserimento carne Inlet (mm)	Piastra in dotazione Standard plate (mm)	
TS 12 UNGER	230/50 230-400/50	1,10 (1,50)	140	200	ø 52	1/2 UNGER ø 0-6	
TI 12 UNGER		1,10 (1,50)		200			
TI 12 R UNGER		1,10 (1,50)		250			
TS 22 UNGER		1,10 (1,50)		300			
TI 22 UNGER		1,10 (1,50)		300		350/400	1/2 UNGER ø 0-6 oppure UNGER TOTALE ø 0-10-6
TI 22 R UNGER		1,50 (2,00)					
TI 32 RS UNGER		1,60 (2,20)		500		ø 52 / ø 76	UNGER TOTALE ø 0-10-6
TI 32 R UNGER		2,20 (3,00)		600		ø 52 / ø 76	
TI 32 R^{PRO} UNGER	230-400/50	2,20 (3,00)	600	ø 76			

	NORME CE / CE APPROVED				SENZA NORME CE / NON CE APPROVED			
	Gruppo Macinazione				Mincing group			
	Ghisa Alimentare 1/2 Unger	Acciaio Inox 1/2 Unger	Ghisa Alimentare Unger Totale	Acciaio Inox Unger Totale	Food Grade Cast Iron 1/2 Unger	Stainless Steel 1/2 Unger	Food Grade Cast Iron Total Unger	Stainless Steel Total Unger
TS 12 UNGER 230/400V trifase three phase codice prodotto product code	FTS106U	FTS126U			FTS106UE	FTS126UE		
TS 12 UNGER 230V monofase single phase codice prodotto product code	FTS107U	FTS127U			FTS107UE	FTS127UE		
TI 12 UNGER 230/400V trifase three phase codice prodotto product code	FTI106U	FTI126U			FTI106UE	FTI126UE		
TI 12 UNGER 230V monofase single phase codice prodotto product code	FTI107U	FTI127U			FTI107UE	FTI127UE		
TS 22 UNGER 230/400V trifase three phase codice prodotto product code	FTS116U	FTS136U	FTS116UT	FTS136UT	FTS116UE	FTS136UE	FTS116UTE	FTS136UTE
TS 22 UNGER 230V monofase single phase codice prodotto product code	FTS117U	FTS137U	FTS117UT	FTS137UT	FTS117UE	FTS137UE	FTS117UTE	FTS137UTE
TI 22 UNGER 230/400V trifase three phase codice prodotto product code	FTI116U	FTI136U	FTI116UT	FTI136UT	FTI116UE	FTI136UE	FTI116UTE	FTI136UTE
TI 22 UNGER 230V monofase single phase codice prodotto product code	FTI117U	FTI137U	FTI117UT	FTI137UT	FTI117UE	FTI137UE	FTI117UTE	FTI137UTE
TI 12 R UNGER 230/400V trifase three phase codice prodotto product code	FTI106RU	FTI126RU			FTI106RUE	FTI126RUE		
TI 12 R UNGER 230V monofase single phase codice prodotto product code	FTI107RU	FTI127RU			FTI107RUE	FTI127RUE		
TI 22 R UNGER 230/400V trifase three phase codice prodotto product code	FTI116RU	FTI136RU	FTI116RUT	FTI136RUT	FTI116RUE	FTI136RUE	FTI116RUTE	FTI136RUTE
TI 22 R UNGER 230V monofase single phase codice prodotto product code	FTI117RU	FTI137RU	FTI117RUT	FTI137RUT	FTI117RUE	FTI137RUE	FTI117RUTE	FTI137RUTE
TI 32 RS UNGER 230/400V trifase three phase codice prodotto product code				FTI138RSUT				FTI138RSUTE
TI 32 RS UNGER 230V monofase single phase codice prodotto product code				FTI139RSUT				FTI139RSUTE
FINV inversione di marcia gear reverse option	su richiesta / on request				di serie / included			
TI 32 R UNGER 230/400V trifase three phase codice prodotto product code				FTI138RUT				FTI138RUTE
TI 32 R UNGER 230V monofase single phase codice prodotto product code				FTI139RUT				FTI139RUTE
TI 32 R PRO UNGER 230/400V trifase three phase codice prodotto product code				FTI139RPUT				
FINV inversione di marcia gear reverse option	di serie / included				di serie / included			

APPLICAZIONI SOLO PER TRITACARNE O TRITACARNE GRATTUGIA MOD. 12 O 22 **ESCLUSO UNIKO** • AVAILABLE FOR MEAT MINCER AND COMBO MEAT MINCER AND GRATER MOD. 12 OR 22 ONLY - **NOT SUITABLE FOR UNIKO MODELS** • TUTTE LE APPLICAZIONI SONO DA INTENDERSI SENZA MACCHINARIO - DEVICES PRICES ARE NOT INCLUSIVE OF MEAT MINCER • LE APPLICAZIONI SONO ADATTE SIA PER MACCHINARI **CE** CHE PER MACCHINARI **NON CE** - DEVICES ARE SUITABLE FOR **CE** AND **NON CE** APPROVED MODEL

GRUPPO CARNE MEZZO UNGER

HALF UNGER SYSTEM MINCING ASSEMBLY



Ghisa Alimentare Food Grade Cast Iron	Acciaio Inox Stainless Steel
FOTM12GU	FOTM12IU
FOTM22GU	FOTM22IU

Mod. 12 Bocca, coclea con perno, volantino, n° 2 piastre, cottello Mouth, screw, handwheel, n° 2 plates, knife
codice prodotto product code

Mod. 22 Bocca, coclea con perno, volantino, n° 2 piastre, cottello Mouth, screw, handwheel, n° 2 plates, knife
codice prodotto product code

GRUPPO CARNE UNGER TOTALE

TOTAL UNGER SYSTEM MINCING ASSEMBLY



Ghisa Alimentare Food Grade Cast Iron	Acciaio Inox Stainless Steel
FOTM22GUT	FOTM22IUT
	FOTM32IUT

Mod. 22 Bocca, coclea con perno, volantino, n° 3 piastre, n° 2 coltelli Mouth, screw, handwheel, n° 3 plates, n° 2 knives
codice prodotto product code

Mod. 32 Bocca, coclea con perno, volantino, n° 3 piastre, n° 2 coltelli Mouth, screw, handwheel, n° 3 plates, n° 2 knives
codice prodotto product code

RICAMBI PER TRITACARNE UNGER

SPARE PARTS FOR UNGER MINCER



Piastra e coltelli Acciaio Inox
Stainless Steel plates and knives

	Modello 12	Modello 22	Modello 32
Piastra ø 0 mm Plate ø 0 mm codice prodotto product code	F0400U	F0401U	F0402U
Piastra ø 2 mm Plate ø 2 mm codice prodotto product code	F0406U	F0409U	F0412U
Piastra ø 3 mm Plate ø 3 mm codice prodotto product code	F0407U	F0410U	F0413U
Piastra ø 3,5 mm Plate ø 3,5 mm codice prodotto product code	F3142U	F3149U	F3156U
Piastra ø 4,5 mm Plate ø 4,5 mm codice prodotto product code	F0408U	F0411U	F0414U
Piastra ø 6 mm Plate ø 6 mm codice prodotto product code	F3136U	F3138U	F3140U
Piastra ø 8 mm Plate ø 8 mm codice prodotto product code	F3137U	F3139U	F3141U
Piastra ø 10 mm Plate ø 10 mm codice prodotto product code	F3143U	F3150U	F3157U
Piastra ø 12 mm Plate ø 12 mm codice prodotto product code	F3144U	F3151U	F3158U
Piastra ø 14 mm Plate ø 14 mm codice prodotto product code	F3145U	F3152U	F3159U
Piastra ø 16 mm Plate ø 16 mm codice prodotto product code	F3146U	F3153U	F3160U
Piastra ø 18 mm Plate ø 18 mm codice prodotto product code	F3147U	F3154U	F3161U
Piastra ø 20 mm Plate ø 20 mm codice prodotto product code	F3148U	F3155U	F3162U
Coltello Knife codice prodotto product code	F0415U	F0416U	F0417U

IMBUTI PER INSACCARE

SAUSAGE FILLING FUNNELS



Set 3 imbusti in Moplen per insaccare Mod. 12 - Foro imbusti mm 15/20/25 Sausage filling kit Mod. 12 (3 pcs kit) - Funnel diam mm 15/20/25	F0163/12
Set 3 imbusti in Moplen per insaccare Mod. 22 - Foro imbusti mm 15/20/25 Sausage filling kit Mod. 22 (3 pcs kit) - Funnel diam mm 15/20/25	F0163/22
Set 3 imbusti in Moplen per insaccare Mod. 32 - Foro imbusti mm 15/20/25 Sausage filling kit Mod. 32 (3 pcs kit) - Funnel diam mm 15/20/25	F0163/32
Anello per insaccare Mod. 12 Ring for funnels Mod. 12	F2227
Anello per insaccare Mod. 22 Ring for funnels Mod. 22	F2228
Anello per insaccare Mod. 32 Ring for funnels Mod. 32	F3507



TRITACARNE GRATTUGIA

meatmincer and grater





FUNZIONALITÀ COMPLETA
SENZA COMPROMESSI

TOTAL FUNCTIONALITY
WITHOUT COMPROMISE

TRITACARNE GRATTUGIA SERIE TG
MEAT MINCER AND GRATER TG MODELS

TRITACARNE GRATTUGIA
CARENATO SERIE TGI
FAIRED COMBO MEAT MINCER
AND GRATER TGI MODELS

TRITACARNE GRATTUGIA
SERIE UNIKO
COMBO MEAT MINCER
AND GRATER UNIKO MODELS





TRITACARNE GRATTUGIA SERIE TG COMBO MEAT MINCER & GRATER TG MODELS

- Macchinario per uso professionale • Costruito in lega di alluminio pressofuso • Elegante fascia in acciaio inossidabile sulla carcassa motore • Sistema di riduzione ad ingranaggi elicoidali a bagno d'olio • Motore asincrono produzione nazionale • Termica di protezione • Gruppo macinazione carne: Ghisa / Alluminio / Acciaio Inox • Trafile auto affilanti in acciaio inox di serie • Tramoggia e piatto raccolta prodotto in acciaio inox • Rullo in acciaio con trattamento electroless nickel plating • Disponibile rullo in acciaio inox AISI 304 • Scodella formaggio in acciaio inox • Grata di protezione allo scarico bocca grattugia inox • Micro di protezione alla grattugia • Pestello in ABS • Comandi a 24 volt • Disponibile con inversione di marcia (a richiesta) • Norme CE • Fabbricato in Italia

- Professional equipment • Made from pressure die cast aluminium alloy • Elegant stainless steel motor cover band • Speed reducer with oil immersed gears • Italian make asynchronous motor • Thermal protection • Easy-removable "ENTERPRISE" mincing unit available in: Electroless nickel plated cast iron / Anodized aluminium / AISI 304 stainless steel • Stainless steel self-sharpening draw-plates included • Stainless steel tray and hopper • Stainless steel grating roll plated with nickel electroless • AISI 304 roll option is also available • Stainless steel cheese bowl • Safety Stainless steel protection grid placed at the bottom of the grating mouth • Safety micro switch placed on the mouth inlet • ABS pestle • 24 volt controls • Gear inversion option available • CE approved • Proudly Made in Italy



Gruppi di macinazione - Mincing Groups

	Inox - S/Steel	Alluminio - Aluminium	Ghisa - Cast Iron
TG 8	•	•	•
TG 12	•	•	•
TG 22	•	•	•

	Alimentazione Power supply (Volt/Hz)	Potenza Motor power (Kwatt/Hp)	Giri/m tritacarne Meat mincer (RPM)	Giri/m grattugia Grater (RPM)	Produzione oraria tritacarne Meat mincer production per hour (kg)	Produzione oraria grattugia Grater production per hour (kg)	Bocca grattugia Grater mouth (mm)	Piastra in dotazione Standard plate (mm)
TG 8	230/50	0,38 (0,50)	80	1400	15	30	110x65	ø6
TG 12	230/50	0,75 (1,00)	200	1400	200	50	140x80	
TG 22	230-400/50	1,10 (1,50)	140	900	300	70		

TG 8



Bocca d'uscita tritacarne
Meat mincer barrel (mm)
Ø 60



Peso netto
Net weight (kg)
10,0 kg



Dimensioni prodotto
Product dimension (mm)
D.380 / B.260 / H.360



TG 12



Bocca d'uscita tritacarne
Meat mincer barrel (mm)
Ø 70



Peso netto
Net weight (kg)
22,0 / 20,0 kg



Dimensioni prodotto
Product dimension (mm)
D.550 / B.200 / H.460



TG 22



Bocca d'uscita tritacarne
Meat mincer barrel (mm)
Ø 82



Peso netto
Net weight (kg)
27,0 / 25,0 kg



Dimensioni prodotto
Product dimension (mm)
D.610 / B.220 / H.460



	NORME CE / CE APPROVED		SENZA NORME CE / NON CE APPROVED	
	Gruppo Macinazione		Mincing group	
	Alluminio Alimentare	Acciaio Inox	Food Aluminum	Stainless Steel
TG 8 230V monofase <i>single phase</i> codice prodotto <i>product code</i>	FTGM102	FTGM126	FTGM102E	FTGM126E
MRIM supplemento per rullo in acciaio inox <i>s/steel roll</i>	su richiesta / <i>on request</i>		su richiesta / <i>on request</i>	
TG 12 230/400V trifase <i>three phase</i> codice prodotto <i>product code</i>	FTG126	FTG102	FTG126E	FTG102E
TG 12 230V monofase <i>single phase</i> codice prodotto <i>product code</i>	FTG127	FTG103	FTG127E	FTG103E
TG 22 230/400V trifase <i>three phase</i> codice prodotto <i>product code</i>	FTG208	FTG206	FTG208E	FTG206E
TG 22 230V monofase <i>single phase</i> codice prodotto <i>product code</i>	FTG209	FTG207	FTG209E	FTG207E
FINV inversione di marcia <i>gear reverse option</i>	su richiesta / <i>on request</i>		di serie / <i>included</i>	
MRI supplemento per rullo in acciaio inox <i>s/steel roll</i>	su richiesta / <i>on request</i>		su richiesta / <i>on request</i>	



TRITACARNE GRATTUGIA SERIE TGI

COMBO MEAT MINCER & GRATER TG I MODELS



- Macchinario per uso professionale • Struttura in lamiera di acciaio inox AISI 304 • Sistema di riduzione ad ingranaggi elicoidali a bagno d'olio • Motore asincrono produzione nazionale • Termica di protezione • Gruppo macinazione carne: Ghisa / Alluminio / Acciaio Inox • Trafile auto affilanti in acciaio inox di serie • Tramoggia e piatto raccolta prodotto in acciaio inox • Rullo in acciaio con trattamento electroless nikel plating • Disponibile rullo in acciaio inox AISI 304 • Scodella formaggio in acciaio inox • Grata di protezione allo scarico bocca grattugia inox • Micro di protezione alla grattugia • Pestello in ABS • Comandi a 24 volt • Disponibile con inversione di marcia (a richiesta) • Rullo fresato (disponibile a richiesta) • Norme CE • Fabbricato in Italia

- Professional equipment • AISI 304 stainless steel plated case • Speed reducer with oil immersed gears • Italian make asynchronous motor • Thermal protection • Easy-removable "ENTERPRISE" mincing unit available in: Electroless nikel plated cast iron / Anodized aluminium / AISI 304 stainless steel • Stainless steel self-sharpening draw-plates included • Stainless steel tray and hopper • Stainless steel grating roll plated with nikel electroless • AISI 304 roll option is also available • Stainless steel cheese bowl • Safety Stainless steel protection grid placed at the bottom of the grating mouth • Safety micro switch placed on the mouth inlet • ABS pestle • 24 volt controls • Gear inversion option available • Milled roll available on request • CE approved • Proudly Made in Italy

Gruppi di macinazione - Mincing Groups

	Inox - S/Steel	Alluminio - Aluminium	Ghisa - Cast Iron
TGI 8	•	•	•
TGI 12	•	•	•
TGI 22	•	•	•

	Alimentazione Power supply (Volt/Hz)	Potenza Motor power (Kwatt/Hp)	Giri/m tritacarne Meat mincer (RPM)	Giri/m grattugia Grater (RPM)	Produzione oraria tritacarne Meat mincer production per hour (kg)	Produzione oraria grattugia Grater production per hour (kg)	Bocca grattugia Grater mouth (mm)	Piastra in dotazione Standard plate (mm)
TGI 8	230/50	0,38 (0,50)	80	1400	15	30	110x65	ø6
TGI 12	230/50	0,75 (1,00)	200	1400	200	50	140x80	
TGI 22	230-400/50	1,10 (1,50)	140	900	300	70		

TGI 8



Bocca d'uscita tritacarne
Meat mincer barrel (mm)
Ø 60



Peso netto
Net weight (kg)
12,0 kg



Dimensioni prodotto
Product dimension (mm)
D.400 / B.280 / H.360



TGI 12



Bocca d'uscita tritacarne
Meat mincer barrel (mm)
Ø 70



Peso netto
Net weight (kg)
25,0 / 23,0 kg



Dimensioni prodotto
Product dimension (mm)
D.590 / B.220 / H.440



TGI 22



Bocca d'uscita tritacarne
Meat mincer barrel (mm)
Ø 82



Peso netto
Net weight (kg)
28,0 / 26,0 kg



Dimensioni prodotto
Product dimension (mm)
D.610 / B.220 / H.440



	NORME CE / CE APPROVED		SENZA NORME CE / NON CE APPROVED	
	Gruppo Macinazione		Mincing group	
	Alluminio Alimentare	Acciaio Inox	Food Aluminum	Stainless Steel
TGI 8 230V monofase <i>single phase</i> codice prodotto <i>product code</i>	FTGM1102	FTGM126	FTGM1102E	FTGM126E
MRIM supplemento per rullo in acciaio inox <i>s/steel roll</i>	su richiesta / <i>on request</i>		su richiesta / <i>on request</i>	
TGI 12 230/400V trifase <i>three phase</i> codice prodotto <i>product code</i>	FTGI126	FTGI102	FTGI126E	FTGI102E
TGI 12 230V monofase <i>single phase</i> codice prodotto <i>product code</i>	FTGI127	FTGI103	FTGI127E	FTGI103E
TGI 22 230/400V trifase <i>three phase</i> codice prodotto <i>product code</i>	FTGI208	FTGI206	FTGI208E	FTGI206E
TGI 22 230V monofase <i>single phase</i> codice prodotto <i>product code</i>	FTGI209	FTGI210	FTGI209E	FTGI210E
FINV inversione di marcia <i>gear reverse option</i>	su richiesta / <i>on request</i>		di serie / <i>included</i>	
MRI supplemento per rullo in acciaio inox <i>s/steel roll</i>	su richiesta / <i>on request</i>		su richiesta / <i>on request</i>	



TRITACARNE GRATTUGIA SERIE UNIKO

COMBO MEAT MINCER & GRATER UNIKO MODELS

• Macchinario per uso professionale • Corpo in lega di alluminio pressofuso (TGK) • Struttura in lamiera di acciaio inox (TGIK) • Sistema di riduzione ad ingranaggi elicoidali a bagno d'olio • Robusto motore asincrono di produzione nazionale • Termica di protezione • Gruppo macinazione carne: Acciaio Inox • Trafilte auto affilanti in acciaio inox di serie • Tramoggia e piatto raccolta prodotto in acciaio inox • Pestello in ABS • Micro di protezione alla bocca grattugia • Grata in acciaio inox allo scarico della grattugia • Comandi a 24 volt • Disponibile con inversione di marcia (a richiesta) • Norme CE • Fabbricato in Italia

• Professional equipment • Pressure die cast aluminium alloy cover casing (TGK) • Structured in stainless steel plating (TGIK) • Speed reducer with oil immersed gears • Heavy duty Italian make asynchronous motor • Thermal protection • AISI 304 stainless steel easy-removable "ENTERPRISE" mincing unit • Stainless steel self-sharpening draw-plates included • Stainless steel tray and hopper • ABS pestle • Safety micro switch placed on the mouth inlet • Safety Stainless steel protection grid placed at the bottom of the grating mouth • 24 volt controls • Gear inversion option available • CE approved • Proudly Made in Italy



Gruppo macinazione inox completamente smontabile
Completely removable stainless steel mincing group

Gruppi di macinazione - Mincing Groups

	Inox - S/Steel	Alluminio - Aluminium	Ghisa - Cast Iron
TGK 12	•	•	•
TGK 22	•	•	•
TGIK 12	•	•	•
TGIK 22	•	•	•

	Alimentazione Power supply (Volt/Hz)	Potenza Motor power (Kwatt/Hp)	Giri/m tritacarne Meat mincer (RPM)	Giri/m grattugia Grater (RPM)	Produzione oraria tritacarne Meat mincer production per hour (kg)	Produzione oraria grattugia Grater production per hour (kg)	Bocca grattugia Grater mouth (mm)	Piastra in dotazione Standard plate (mm)
TGK 12	230/50 230-400/50	0,75 (1,00)	200	1400	200	50	140x80	ø6
TGK 22		1,10 (1,50)	140	900	300	70		
TGIK 12			200	1400	200	50		
TGIK 22		140	900	300	70			

TGK 12



Bocca d'uscita tritacarne
Meat mincer barrel (mm)
Ø 70



Peso netto
Net weight (kg)
25,0 / 23,0 kg



Dimensioni prodotto
Product dimension (mm)
D. 220 / B. 610 / H. 470



TGK 22



Bocca d'uscita tritacarne
Meat mincer barrel (mm)
Ø 82



Peso netto
Net weight (kg)
29,0 / 27,0 kg



Dimensioni prodotto
Product dimension (mm)
D. 240 / B. 670 / H. 500



TGIK 12



Bocca d'uscita tritacarne
Meat mincer barrel (mm)
Ø 70



Peso netto
Net weight (kg)
26,0 / 24,0 kg



Dimensioni prodotto
Product dimension (mm)
D. 220 / B. 640 / H. 430



TGIK 22



Bocca d'uscita tritacarne
Meat mincer barrel (mm)
Ø 82



Peso netto
Net weight (kg)
29,0 / 27,0 kg



Dimensioni prodotto
Product dimension (mm)
D. 220 / B. 660 / H. 430



	NORME CE / CE APPROVED	SENZA NORME CE / NON CE APPROVED
	Gruppo Macinazione	Mincing group
	Acciaio Inox	Stainless Steel
TGK 12 230/400V trifase three phase codice prodotto product code	FTGK102	FTGK102E
TGK 12 230V monofase single phase codice prodotto product code	FTGK103	FTGK103E
TGK 22 230/400V trifase three phase codice prodotto product code	FTGK206	FTGK206E
TGK 22 230V monofase single phase codice prodotto product code	FTGK207	FTGK207E
TGIK 12 230/400V trifase three phase codice prodotto product code	FTGIK102	FTGIK102E
TGIK 12 230V monofase single phase codice prodotto product code	FTGIK103	FTGIK103E
TGIK 22 230/400V trifase three phase codice prodotto product code	FTGIK206	FTGIK206E
TGIK 22 230V monofase single phase codice prodotto product code	FTGIK210	FTGIK210E
FINV inversione di marcia gear reverse option	su richiesta / on request	di serie / included
MRI supplemento per rullo in acciaio inox s/steel roll	su richiesta / on request	su richiesta / on request

GRUPPO CARNE ENTERPRISE

ENTERPRISE MINCING ASSEMBLY



	Alluminio Alimentare <i>Food Grade Aluminium</i>	Ghisa Alimentare <i>Food Grade Cast Iron</i>	Acciaio Inox <i>Stainless Steel</i>
Mod. 8 Bocca, coclea con perno, volantino, n° 1 piastra, coltello <i>Mouth, screw, handwheel, n° 1 plate, knife</i> codice prodotto <i>product code</i>	FOTM8A		FOTM8I
Mod. 12 Bocca, coclea con perno, volantino, n° 1 piastra, coltello <i>Mouth, screw, handwheel, n° 1 plate, knife</i> codice prodotto <i>product code</i>	FOTM12A	FOTM12G	FOTM12I
Mod. 22 Bocca, coclea con perno, volantino, n° 1 piastra, coltello <i>Mouth, screw, handwheel, n° 1 plate, knife</i> codice prodotto <i>product code</i>	FOTM22A	FOTM22G	FOTM22I

I RICAMBI SONO ADATTI SIA PER MACCHINARI **CE** CHE PER MACCHINARI **NON CE** - ACCESSORIES ARE SUITABLE FOR **CE** AND **NON CE** APPROVED MODEL

RICAMBI PER TRITACARNE ENTERPRISE

SPARE PARTS FOR ENTERPRISE MINCER



Piastre e coltelli Acciaio Inox
Stainless Steel plates and knives

	Modello 8	Modello 12	Modello 22
Piastra ø 2 mm <i>Plate ø 2 mm</i> codice prodotto <i>product code</i>	F0403	F0406	F0409
Piastra ø 3 mm <i>Plate ø 3 mm</i> codice prodotto <i>product code</i>	F0404	F0407	F0410
Piastra ø 3,5 mm <i>Plate ø 3,5 mm</i> codice prodotto <i>product code</i>	F0405	F0408	F0411
Piastra ø 4,5 mm <i>Plate ø 4,5 mm</i> codice prodotto <i>product code</i>	F2045	F2131	F2219
Piastra ø 6 mm <i>Plate ø 6 mm</i> codice prodotto <i>product code</i>	F3134	F3136	F3138
Piastra ø 8 mm <i>Plate ø 8 mm</i> codice prodotto <i>product code</i>	F3135	F3137	F3139
Coltello <i>Knife</i> codice prodotto <i>product code</i>	F2044	F2130	F2218

IMBUTI PER INSACCARE

SAUSAGE FILLING FUNNELS



Set 3 imbuti in Moplen per insaccare Mod. 8 - Foro imbuti mm 15/20/25 <i>Sausage filling kit Mod. 08 (3 pcs kit) - Funnel diam mm 15/20/25</i>	F0163/8
Set 3 imbuti in Moplen per insaccare Mod. 12 - Foro imbuti mm 15/20/25 <i>Sausage filling kit Mod. 12 (3 pcs kit) - Funnel diam mm 15/20/25</i>	F0163/12
Set 3 imbuti in Moplen per insaccare Mod. 22 - Foro imbuti mm 15/20/25 <i>Sausage filling kit Mod. 22 (3 pcs kit) - Funnel diam mm 15/20/25</i>	F0163/22
Set 3 imbuti in Moplen per insaccare Mod. 32 - Foro imbuti mm 15/20/25 <i>Sausage filling kit Mod. 32 (3 pcs kit) - Funnel diam mm 15/20/25</i>	F0163/32
Anello per insaccare Mod. 8 <i>Ring for funnels Mod. 8</i>	F2939
Anello per insaccare Mod. 12 <i>Ring for funnels Mod. 12</i>	F2227
Anello per insaccare Mod. 22 <i>Ring for funnels Mod. 22</i>	F2228
Anello per insaccare Mod. 32 <i>Ring for funnels Mod. 32</i>	F3507

APPLICAZIONI SOLO PER TRITACARNE O TRITACARNE GRATTUGIA MOD. 12 O 22 **ESCLUSO UNIKO** • AVAILABLE FOR MEAT MINCER AND COMBO MEAT MINCER AND GRATER MOD. 12 OR 22 ONLY - **NOT SUITABLE FOR UNIKO MODELS** • TUTTE LE APPLICAZIONI SONO DA INTENDERSI SENZA MACCHINARIO - DEVICES PRICES ARE NOT INCLUSIVE OF MEAT MINCER • LE APPLICAZIONI SONO ADATTE SIA PER MACCHINARI **CE** CHE PER MACCHINARI **NON CE** - DEVICES ARE SUITABLE FOR **CE** AND **NON CE** APPROVED MODEL

APPLICAZIONE PASSAPOMODORO

TOMATO SQUEEZER DEVICE



Mod. 22 Applicazioni per il nostro tritacarne Mod. 22 Device for model 22

FPP101

APPLICAZIONE PASSAPUREA

POTATO MASHER DEVICE



Mod. 12 Applicazioni per il nostro tritacarne Mod. 12 Device for model 12

FPP102

Mod. 22 Applicazioni per il nostro tritacarne Mod. 22 Device for model 22

FPP103



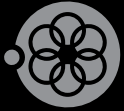

SERIE RETRÒ
retrò models

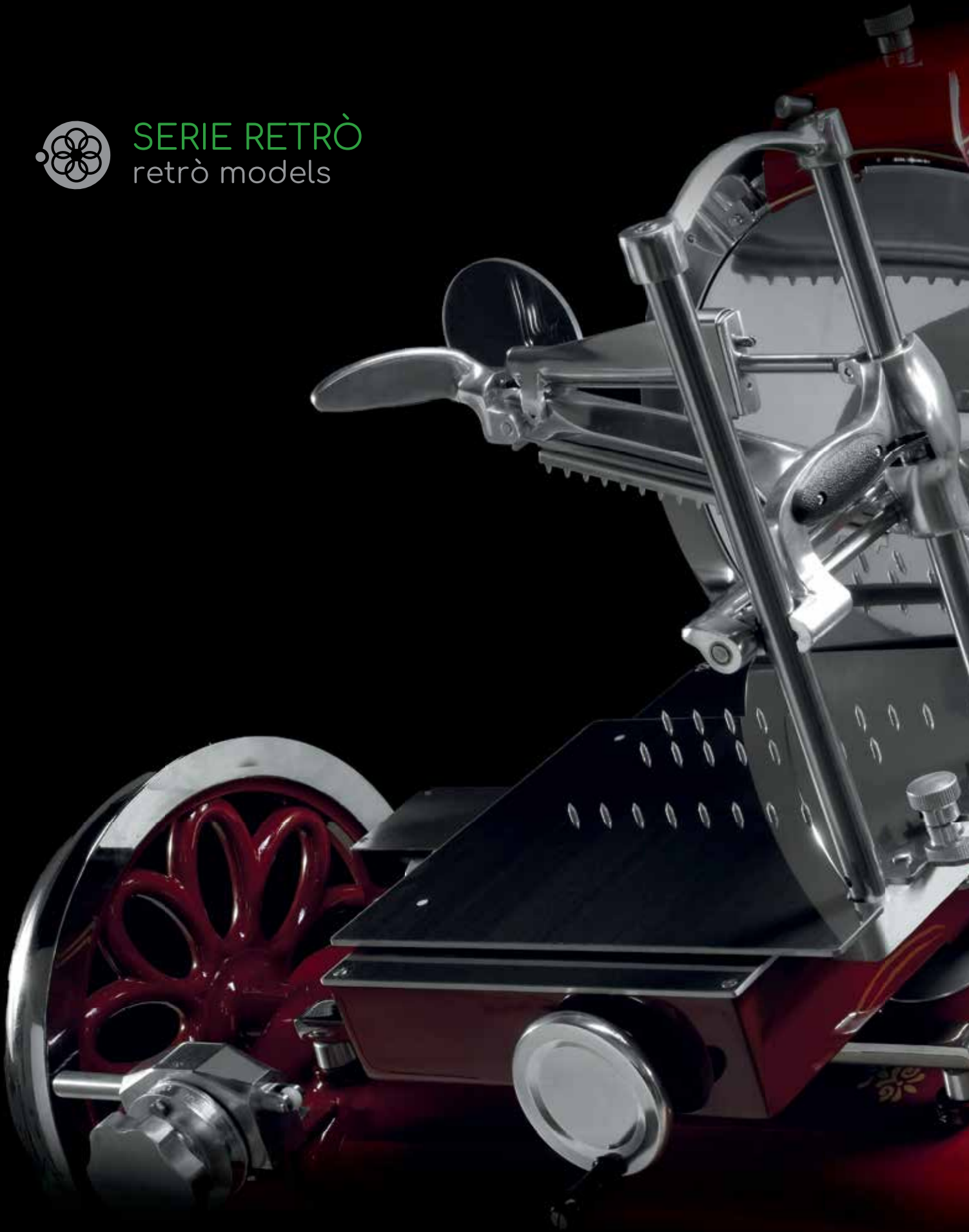



RICORDANDO ANTICHI SAPORI
CON CLASSE ED ELEGANZA

OLD TIME FL AVOURS
HIGH-CLASS AND GRACE

SERIE RETRÒ MIGNON
RETRÒ MIGNON MODELS

SERIE RETRÒ PROFESSIONAL
RETRÒ PROFESSIONAL MODELS

AFFETTATRICI VOLANO RETRÒ
RETRÒ FLYWHEEL SLICER

AFFETTATRICI RETRÒ SERIE R
RETRÒ SLICING MACHINES R MODELS

AFFETTATRICI RETRÒ SERIE GR
RETRÒ SLICING MACHINES GR MODELS





RETRÒ SERIE MIGNON

RETRÒ MIGNON MODELS

- Apparecchi per uso semiprofessionale e domestico • Ideale per abitazioni e piccoli ristoranti • Corpo in lega di alluminio pressofuso e verniciato • Sistema di riduzione ad ingranaggi elicoidali a bagno d'olio • Robusto motore a induzione di produzione nazionale • Termica di protezione • Gruppo macinazione carne "enterprise" asportabile in alluminio o in acciaio inox • Dimensioni carico tritacarne 52x 120 mm • Dimensioni scarico tritacarne 60 mm • Trafilte auto affilanti in acciaio inox di serie • Tramoggia in acciaio inox • Rullo grattugia in acciaio • Disponibile in AISI 304 • Micro di protezione al carico della bocca grattugia • Grata di protezione allo scarico della bocca grattugia in acciaio inox • Scodella raccolta formaggio inox • Pestello in ABS • Comandi a 24 volt • Norme CE • Fabbricata in Italia

- Household and semi-professional equipment • Ideally suited for the small restaurants and home use • Pressure die cast aluminium alloy and varnished case • Speed reducer with oil immersed gears • Italian make heavy duty induction motor • Thermal protection • Easy-removable "ENTERPRISE" mincing unit available in stainless steel or aluminium • Loading meat inlet dimensions: 52x120 mm • Output mouth dimensions: 60 mm • Stainless steel self-sharpening draw-plates • Stainless steel hopper • Stainless steel grating roll • AISI 304 option is also available • Safety micro switch placed on the mouth inlet • Safety stainless steel protection grid placed at the bottom of the grating mouth • Stainless steel cheese bowl • ABS pestle • 24 volt controls • CE approved • Proudly Made in Italy



Gruppi di macinazione - Mincing Groups

	Inox - S/Steel	Alluminio - Aluminium	Ghisa - Cast Iron
TS 8 R	•	•	•
TG 8 R	•	•	•

	Alimentazione Power supply (Volt/Hz)	Potenza Motor power (Kwatt/Hp)	Giri/m tritacarne Meat mincer (RPM)	Giri/m grattugia Grater (RPM)	Produzione oraria tritacarne Meat mincer production per hour (kg)	Produzione oraria grattugia Grater production per hour (kg)	Piastra in dotazione Standard plate (mm)
TS 8 R	230/50	0,38 (0,50)	80	-	15	-	ø6
TG 8 R			80	1400	15	30	
GM R			-	1400	-	30	

TS 8 R



Bocca d'uscita
Barrel (mm)
Ø 60



Peso netto
Net weight (kg)
9,0 kg



Dimensioni prodotto
Product dimension (mm)
D. 260 / B. 270 / H. 360



TG 8 R



Bocca d'uscita
Barrel (mm)
Ø 60



Peso netto
Net weight (kg)
10,0 kg



Dimensioni prodotto
Product dimension (mm)
D. 260 / B. 380 / H. 360



GM R



Bocca grattugia
Grater mouth (mm)
110x65



Peso netto
Net weight (kg)
8,0 kg



Dimensioni prodotto
Product dimension (mm)
D. 170 / B. 280 / H. 310



NORME CE / CE APPROVED

Gruppo Macinazione

TS 8 R 230V monofase single phase

codice prodotto product code

TG 8 R 230V monofase single phase

codice prodotto product code

GM R 230V monofase single phase

codice prodotto product code

MRIM rullo in acciaio inox s/steel roll

Alluminio Alimentare

Acciaio Inox

FTSMR101

FTSMR126

FTGMR102

FTGMR126

FGMR113

su richiesta / on request



RETRÒ SERIE PROFESSIONAL

RETRÒ PROFESSIONAL SERIES

- Apparecchi per uso professionale • Ideale per ristoranti e macellerie in "stile" • Corpo in lega di alluminio pressofuso e verniciato • Sistema di riduzione ad ingranaggi elicoidali a bagno d'olio • Robusto motore a induzione di produzione nazionale • Termica di protezione • Gruppo macinazione carne "enterprise" asportabile • In ghisa alimentare o acciaio inox • Dimensioni carico tritacarne 52x120 mm • Dimensioni scarico tritacarne 70 mm • Trafle auto affilanti in acciaio inox di serie • Tramoggia in acciaio inox • Rullo grattugia in acciaio • Disponibile in AISI 304 • Micro di protezione al carico della bocca grattugia • Grata di protezione allo scarico della bocca grattugia in acciaio inox • Scodella raccolta formaggio inox • Pestello in ABS • Comandi a 24 volt • Norme CE • Fabbricata in Italia

- Professional equipment • Particularly suitable for "stylish" restaurants and butcheries • Pressure die cast aluminium alloy and varnished case • Speed reducer with oil immersed gears • Italian make heavy duty induction motor • Thermal protection • Easy-removable "ENTERPRISE" mincing unit • Available in cast iron or stainless steel • Loading meat inlet dimensions: 52x120 mm • Output mouth dimensions: 70 mm • Stainless steel self-sharpening draw-plates • Stainless steel hopper • Stainless steel grating roll • AISI 304 option is also available • Safety micro switch placed on the mouth inlet • Safety Stainless steel protection grid placed at the bottom of the grating mouth • Stainless steel cheese bowl • ABS pestle • 24 volt controls • CE approved • Proudly Made in Italy



Gruppi di macinazione - Mincing Groups

	Inox - S/Steel	Alluminio - Aluminium	Ghisa - Cast Iron
TS 12 R	•	•	•
TG 12 R	•	•	•

	Alimentazione Power supply (Volt/Hz)	Potenza Motor power (Kwatt/Hp)	Giri/m tritacarne Meat mincer (RPM)	Giri/m grattugia Grater (RPM)	Produzione oraria tritacarne Meat mincer production per hour (kg)	Produzione oraria grattugia Grater production per hour (kg)	Piastra in dotazione Standard plate (mm)
TS 12 R	230/50 230-400/50	0,75 (1,00)	200	-	150/200	-	ø6
TG 12 R			200	1400	200	50	ø6
GSR			-	1400	-	50	-

TS 12 R



Bocca d'uscita
Barrel (mm)
Ø 70



Peso netto (mono/trifase)
Net weight single/three phase (kg)
19,0 / 19,0 kg



Dimensioni prodotto
Product dimension (mm)
D. 220 / B. 370 / H. 440



TG 12 R



Bocca d'uscita
Barrel (mm)
Ø 70



Peso netto (mono/trifase)
Net weight single/three phase (kg)
22,0 / 22,0 kg



Dimensioni prodotto
Product dimension (mm)
D. 220 / B. 550 / H. 460



GS R



Bocca grattugia
Grater mouth (mm)
140x80



Peso netto (mono/trifase)
Net weight single/three phase (kg)
18,0 / 18,0 kg



Dimensioni prodotto
Product dimension (mm)
D. 220 / B. 380 / H. 380



NORME CE / CE APPROVED

Gruppo Macinazione

	Ghisa Alimentare	Acciaio Inox
TS 12 R 230/400V trifase three phase codice prodotto <i>product code</i>	FTSR106	FTSR126
TS 12 R 230V monofase single phase codice prodotto <i>product code</i>	FTSR107	FTSR127
TG 12 R 230/400V trifase three phase codice prodotto <i>product code</i>	FTGR126	FTGR102
TG 12 R 230V monofase single phase codice prodotto <i>product code</i>	FTGR127	FTGR103
FINV inversione di marcia <i>gear reverse option</i>	su richiesta / on request	
GSR 230/400V trifase three phase codice prodotto <i>product code</i>	FGSR106	
GS R 230V monofase single phase codice prodotto <i>product code</i>	FGSR107	
MRI supplemento per rullo in acciaio inox <i>s/steel roll</i>	su richiesta / on request	



RETRÒ AFFETTATRICI A VOLANO

RETRÒ FLOWER WHEEL VOLANO MANUAL SLICERS

• Apparecchi per uso professionale • Ideale per hotel, negozi, bar, ristoranti e macellerie in "stile" • Funzionamento manuale • Struttura in lega di alluminio con fusione in conchiglia per garantire una durata nel tempo ed elevata affidabilità • Superficie verniciata a "fuoco" per ottenere una lucentezza ed un'igiene ottimali • Affilatoio superiore di serie e di facile utilizzo • Anello paralama fisso • Rapida pulizia • Norme CE • Fabbriata in Italia

• Professional equipment • Particularly suitable for "stylish" restaurants, butcheries, hotel, bar, shops • This unit is fully hand-operated • Heavy structure with aluminium with chilled casting to grant life and a good reliability • Fire painted surface to get a sheen and optimum hygiene • Upper sharpener standard and easy to use • Fixed blade protecting ring • Rapid cleaning • CE approved • Proudly Made in Italy



Capacità di taglio Cutting capacity (mm)	Spessore di taglio Slice thickness (mm)	Base d'appoggio affettatrice Slicer cutting area (mm)	Dimensione pedistallo Pedestal dimensions (mm)
---	--	---	---

VOLANO 250 R

185x150

0=2,3 - (8 posizioni)

380x290

650x800

VOLANO 300 R

230x190

0=2,5 - (9 posizioni)

400x340

650x800

VOLANO 350 R

270x240

0=2,5 - (9 posizioni)

650x400

650x800

250 R



Lama
Blade size (mm)
Ø 250



Peso netto affettatrice
Slicer net weight (kg)
33,0 kg

Peso netto colonna
Slicer net weight (kg)
43,0 kg



Dimensioni prodotto
Product dimension (mm)
D. 520 / B. 680 / H. 510



300 R



Lama
Blade size (mm)
Ø 300



Peso netto affettatrice
Slicer net weight (kg)
46,0 kg

Peso netto colonna
Slicer net weight (kg)
46,0 kg



Dimensioni prodotto
Product dimension (mm)
D. 600 / B. 670 / H. 950

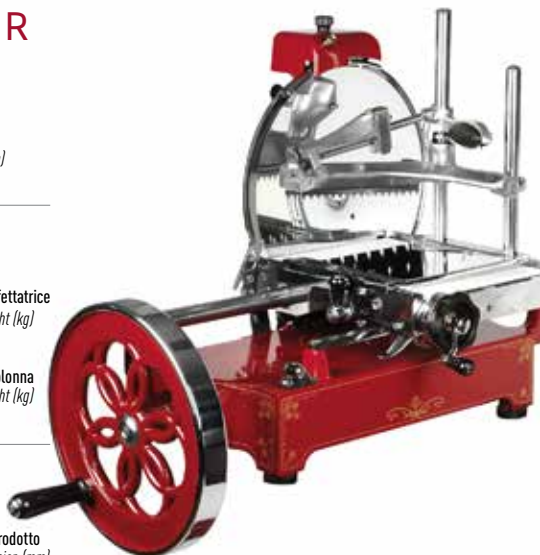

350 R



Lama
Blade size (mm)
Ø 350



Peso netto affettatrice
Slicer net weight (kg)
81,0 kg

Peso netto colonna
Slicer net weight (kg)
54,0 kg



Dimensioni prodotto
Product dimension (mm)
D. 710 / B. 870 / H. 800



VOLANO 250 R

codice prodotto product code

VOLANO 300 R

codice prodotto product code

VOLANO 350 R

codice prodotto product code

BASAMENTO PER VOLANO 250 R / 300 R

codice prodotto product code

BASAMENTO PER VOLANO 350 R

codice prodotto product code

SENZA DECORAZIONI / WITHOUT DECORATIONS

FAV250

FAV300

FAV350

FBAS

FBAS350

CON DECORAZIONI / WITH DECORATIONS

FAV250D

FAV300D

FAV350D

FBASD

FBAS350D



RETRÒ AFFETTATRICI GRAVITÀ SERIE R GRAVITY RETRÒ STYLE SLICERS R SERIES

• Macchinario per uso professionale • Realizzata in lega di alluminio trattata anodicamente • Motore asincrono ventilato • Lama di produzione nazionale • Anello di protezione • Boccole carrello autolubrificanti • Ampio piatto porta salumi • Protezione in plastica al carrello • Curata nei dettagli • Trasmissione a cinghia • Affilatoio incorporato • Facile da pulire • Norme CE • Fabbricata in Italia

• Professional equipment • Slicer made from highly food-grade aluminium • Ventilated asynchronous motor • Italian made blades • Safety ring • Permanently lubricated carriage ball bearings • Capacious food plate • Safety carriage plastic cover • High quality gravity feed slicer • Belt transmission • Sharpening accessory included • Easy clean up • CE approved • Proudly Made in Italy



	Alimentazione Power supply (Volt/Hz)	Potenza Motor power (Kwatt/Hp)	Capacità di taglio Cutting capacity (mm)	Giri/m lama al minuto Blade revolution (RPM)	Corsa Carrello Carriage sliding (mm)	Spessore di taglio Slice thickness (mm)	Base d'appoggio affettatrice Slicer cutting area (mm)
220 R	230 / 50-60	0,18 (0,25)	190x160	300	240	0÷15	415x280
250 R		0,18 (0,25)	220x190		260	0÷16	440x290
275 R		0,22 (0,35)	220x210		270	0÷16	440x290

220 R



Lama
Blade size (mm)
Ø 220



Peso netto
Net weight (kg)
13,5 kg



Dimensioni prodotto
Product dimension (mm)
D. 580 / B. 405 / H. 340



250 R



Lama
Blade size (mm)
Ø 250



Peso netto
Net weight (kg)
15,5 kg



Dimensioni prodotto
Product dimension (mm)
D. 620 / B. 425 / H. 360



275 R



Lama
Blade size (mm)
Ø 275



Peso netto
Net weight (kg)
16,5 kg



Dimensioni prodotto
Product dimension (mm)
D. 620 / B. 440 / H. 390



220 ROSSA 230V monofase *single phase*

codice prodotto *product code*

250 ROSSA 230V monofase *single phase*

codice prodotto *product code*

275 ROSSA 230V monofase *single phase*

codice prodotto *product code*

NORME CE / CE APPROVED

FAFR223

FAFR253

FAFR279

SENZA NORME CE / NON CE APPROVED

FAFR223E

FAFR253E

FAFR279E



RETRÒ AFFETTATRICI GRAVITÀ SERIE GR

GRAVITY RETRÒ STYLE SLICERS GR SERIES

- Macchinario per uso professionale • Fusione in lega di alluminio anodizzato • Motore asincrono ventilato • Lama forgiata di produzione nazionale • Anello di protezione alla lama • Boccole carrello autolubrificanti • Blocco al carrello come da normativa • Supporto vela maggiorato • Ampio piatto porta salumi • Curata nei dettagli • Protezione in plastica al carrello • Trasmissione con robusta cinghia in poliesteri • Scheda elettrica a 24 volt • Interruttore digitale • Affilatoio incorporato • Norme CE • Fabbricata in Italia

- Professional equipment • Made from highly polished anodised food-grade aluminium • Ventilated asynchronous motor • Italian made forged blade • Blade safety ring • Permanently lubricated carriage ball bearings • CE approved carriage locking • Capacious food plate • High quality gravity feed slicer • Safety carriage plastic cover • Powerful polyester belt driven transmission • 24 volt low tension card • Digital ON/OFF switch • Sharpening accessory included • CE approved • Proudly Made in Italy



Alimentazione Power supply (Volt/Hz)	Potenza Motor power (Kwatt/Hp)	Capacità di taglio Cutting capacity (mm)	Giri/m lama al minuto Blade revolution (RPM)	Corsa Carrello Carriage sliding (mm)	Spessore di taglio Slice thickness (mm)	Base d'appoggio affettatrice Slicer cutting area (mm)
---	-----------------------------------	---	---	---	--	---

275 GR	230/50 230-400/50	0,26 (0,35)	230x160	300	270	0÷15	470x320
300 GR				280			
330 GR		0,38 (0,50)	240x250	280	330		600x420
350 GR				260			

275 GR



Lama
Blade size (mm)
Ø 275



Peso netto
Net weight (kg)
22,0 kg



Dimensioni prodotto
Product dimension (mm)
D. 630 / B. 500 / H. 420



300 GR



Lama
Blade size (mm)
Ø 300



Peso netto
Net weight (kg)
23,0 kg



Dimensioni prodotto
Product dimension (mm)
D. 630 / B. 500 / H. 420



330 GR



Lama
Blade size (mm)
Ø 330



Peso netto
Net weight (kg)
38,0 kg



Dimensioni prodotto
Product dimension (mm)
D. 780 / B. 500 / H. 480



350 GR



Lama
Blade size (mm)
Ø 350



Peso netto
Net weight (kg)
40,0 kg



Dimensioni prodotto
Product dimension (mm)
D. 800 / B. 500 / H. 480



	NORME CE / CE APPROVED	SENZA NORME CE / NON CE APPROVED
275 ROSSA 230/400V trifase <i>three phase</i> codice prodotto <i>product code</i>	FAR276	FAR276E
275 ROSSA 230V monofase <i>single phase</i> codice prodotto <i>product code</i>	FAR275	FAR275E
300 ROSSA 230/400V trifase <i>three phase</i> codice prodotto <i>product code</i>	FAR301	FAR301E
300 ROSSA 230V monofase <i>single phase</i> codice prodotto <i>product code</i>	FAR300	FAR300E
330 ROSSA 230/400V trifase <i>three phase</i> codice prodotto <i>product code</i>	FAR331	FAR331E
330 ROSSA 230V monofase <i>single phase</i> codice prodotto <i>product code</i>	FAR330	FAR330E
350 ROSSA 230/400V trifase <i>three phase</i> codice prodotto <i>product code</i>	FAR351	FAR351E
350 ROSSA 230V monofase <i>single phase</i> codice prodotto <i>product code</i>	FAR350	FAR350E
FPAA supplemento per pomelleria in alluminio <i>extra charge for aluminium knob</i>	su richiesta / <i>on request</i>	su richiesta / <i>on request</i>



GRATTUGIE
groters



SEMPLICEMENTE EFFICACI
PER OGNI TIPO DI PRODOTTO

SIMPLY EFFECTIVE
FOR ANY KIND OF FOODSTUFF

GRATTUGIE
GRATERS

GRATTUGIE MAXI
MAXI GRATERS





GRATTUGIE MIGNON GRATER MIGNON

• Macchinario per uso professionale • Struttura in acciaio INOX • Corpo in lega di alluminio pressofuso e verniciato • Robusto motore asincrono ventilato di produzione nazionale con termica di protezione • Rullo in acciaio con trattamento electroless nikel plating • Rullo in acciaio Inox AISI 304 (disponibile a richiesta) • Scodella formaggio in acciaio Inox • Grata di protezione allo scarico della bocca grattugia in acciaio inox • Micro di protezione alla grattugia • Norme CE

• Professional equipment • Structured in stainless steel • Pressure die cast aluminium alloy and varnished case • Heavy duty Italian make, ventilated asynchronous motor with thermal protection included • Stainless steel grating roll plated with nikel electroless • AISI 304 roll option available on demand • Stainless steel cheese bowl • Safety stainless steel protection grid placed at the bottom of the grating mouth • Safety micro switch placed on the mouth inlet • CE approved



Alimentazione
Power supply (Volt/Hz)

Potenza
Motor power (Kwatt/Hp)

Giri/m grattugia
Grater (RPM)

Rullo punzonato
grattugia
Stamped grater roll
(mm)

Produzione oraria
grattugia
Grater production per
hour (kg)

	Alimentazione Power supply (Volt/Hz)	Potenza Motor power (Kwatt/Hp)	Giri/m grattugia Grater (RPM)	Rullo punzonato grattugia Stamped grater roll (mm)	Produzione oraria grattugia Grater production per hour (kg)
GM	230/50	0,38 (0,50)	1400	110x60	30
GM R					
GM B					

GM



Bocca grattugia
Grater mouth (mm)
110x65



Peso netto
Net weight (kg)
8,0 kg



Dimensioni prodotto
Product dimension (mm)
D. 170 / B. 280 / H. 310



GM R



Bocca grattugia
Grater mouth (mm)
110x65



Peso netto
Net weight (kg)
8,0 kg



Dimensioni prodotto
Product dimension (mm)
D. 170 / B. 280 / H. 310



GMB



Bocca grattugia
Grater mouth (mm)
110x65



Peso netto
Net weight (kg)
8,0 kg



Dimensioni prodotto
Product dimension (mm)
D. 170 / B. 280 / H. 310



	NORME CE / CE APPROVED	SENZA NORME CE / NON CE APPROVED Non vendibili in Europa - Not suitable for EC countries
GM 230V monofase single phase codice prodotto product code	FGM113	FGM113E
GMR ROSSA 230V monofase single phase codice prodotto product code	FGM113R	FGM113RE
GMB BIANCA 230V monofase single phase codice prodotto product code	FGM113B	FGM113BE
MRIM supplemento per rullo in acciaio inox s/steel roll	su richiesta / on request	su richiesta / on request



GRATTUGIE GRATER

- Macchinario per uso professionale • Costruito in lega di alluminio pressofuso e lucidato • Elegante fascia in acciaio inossidabile sulla carcassa motore • Robusto motore asincrono di produzione nazionale con termica di protezione • Freno motore • Rullo in acciaio con trattamento electroless nickel plating • Rullo in acciaio Inox AISI 304 (disponibile a richiesta) • Rullo fresato (disponibile a richiesta) • Scodella formaggio in acciaio Inox • Grata di protezione allo scarico della bocca grattugia in acciaio inox • Micro di protezione alla grattugia • Comandi a bassata tensione (24 Volt) • Norme CE • Fabbriato in Italia

- Professional equipment • Structured in polished pressure die cast aluminium alloy • Elegant stainless steel motor cover band • Heavy duty Italian make asynchronous motor with thermal protection included • With motor brake • Stainless steel grating roll plated with nickel electroless • AISI 304 roll option available on demand • Milled roll available on request • Stainless steel cheese bowl • Safety stainless steel protection grid placed at the bottom of the grating mouth • Safety micro switch placed on the mouth inlet • 24 volt controls • CE approved • Proudly Made in Italy



	Alimentazione Power supply (Volt/Hz)	Potenza Motor power (Kwatt/Hp)	Giri/m grattugia Grater (RPM)	Rullo punzonato grattugia Stamped grater roll (mm)	Produzione oraria grattugia Grater production per hour (kg)
GS	230/50 230-400/50	0,75 (1,00)	1400	140x75	70
GSD		0,75 (1,00)	1400		70
GSM		1,10 (1,50)	900		90
GD		0,75 (1,00)	1400		70
GG - HP2		1,50 (2,00)		210x107	100
GG - HP4	230-400/50	3,00 (4,00)		309x158	130

GS
Grattugia semplice
 Grater GS



Bocca grattugia
 Grater mouth (mm)
 140x80



Peso netto (mono/trifase)
 Net weight single/three phase (kg)
 18,0 / 18,0 kg



Dimensioni prodotto
 Product dimension (mm)
 D. 220 / B. 380 / H. 380



GSD
Grattugia bocca destra
 Grater GSD right mouthed



Bocca grattugia
 Grater mouth (mm)
 140x80



Peso netto (mono/trifase)
 Net weight single/three phase (kg)
 18,0 / 18,0 kg



Dimensioni prodotto
 Product dimension (mm)
 D. 220 / B. 380 / H. 380



GSM
Grattugia motore maggiorato (HP 1,5)
 Grater GSM higher power motor (HP 1,5)



Bocca grattugia
 Grater mouth (mm)
 140x80



Peso netto (mono/trifase)
 Net weight single/three phase (kg)
 20,0 / 20,0 kg



Dimensioni prodotto
 Product dimension (mm)
 D. 220 / B. 420 / H. 380



GD
Grattugia doppia
 Double grater GD



Bocca grattugia
 Grater mouth (mm)
 140x80



Peso netto (mono/trifase)
 Net weight single/three phase (kg)
 21,0 / 21,0 kg



Dimensioni prodotto
 Product dimension (mm)
 D. 220 / B. 540 / H. 380



GG - HP2
Grattugia Maxi
 Maxi grater HP2



Bocca grattugia
 Grater mouth (mm)
 185x110



Peso netto (mono/trifase)
 Net weight single/three phase (kg)
 38,0 / 38,0 kg



Dimensioni prodotto
 Product dimension (mm)
 D. 280 / B. 500 / H. 570



GG - HP4
Grattugia gigante
 Maxi grater HP4



Bocca grattugia
 Grater mouth (mm)
 300x160



Peso netto (mono/trifase)
 Net weight single/three phase (kg)
 80,0 / 80,0 kg



Dimensioni prodotto
 Product dimension (mm)
 D. 400 / B. 700 / H. 600



APPLICAZIONI

ACCESSORIES



RULLO STANDARD

Realizzato in acciaio ferroso, presenta le punte affilate ed adatto a pane o parmigiano stagionato.

Ironed steel drum (supplied as standard): features sharp ends. Only suitable for grating hard cheese (i.e. parmesan) and bread.



RULLO INOX - MRI

Rullo interamente in acciaio inox AISI 304, presenta punte affilate.

S/steel drum: entirely made of stainless steel features sharp ends.



RULLO FRESATO - MRF

Realizzato in acciaio inox non presenta punte affilate, ma ha dei tronchi di cono adatti a parmigiano poco stagionato, come Pecorino romano o pecorino sardo. Il tipo di grattugiato realizzato è molto simile a quello che si ottiene con la Grattugia a mano.

Milled drum: made of s/steel comes with cone shaped ends. Suitable for grating not too matured cheese (i.e. pecorino romano/sardo). Features coarse grating.

	NORME CE / CE APPROVED	SENZA NORME CE / NON CE APPROVED
GS 230/400V trifase three phase <i>codice prodotto product code</i>	FGS106	FGS106E
GS 230V monofase single phase <i>codice prodotto product code</i>	FGS107	FGS107E
GSD 230/400V trifase three phase <i>codice prodotto product code</i>	FGSD106	FGSD106E
GSD 230V monofase single phase <i>codice prodotto product code</i>	FGSD107	FGSD107E
GSM 230/400V trifase three phase <i>codice prodotto product code</i>	FGSM106	FGSM106E
GSM 230V monofase single phase <i>codice prodotto product code</i>	FGSM107	FGSM107E
GD 230/400V trifase three phase <i>codice prodotto product code</i>	FGD100	
GD 230V monofase single phase <i>codice prodotto product code</i>	FGD101	
MRI supplemento per rullo in acciaio inox s/steel stamped roll	su richiesta / on request	su richiesta / on request
MRF supplemento per rullo in acciaio inox fresato <i>Milled s/steel stamped roll</i>	su richiesta / on request	su richiesta / on request
GG HP2 230/400V trifase three phase <i>codice prodotto product code</i>	FGG108	
GG HP2 230V monofase single phase <i>codice prodotto product code</i>	FGG109	
GG HP4 230/400V trifase three phase <i>codice prodotto product code</i>	FGG106	

• I macchinari senza norme CE sono destinati ai paesi fuori dalla Comunità Europea / Not suitable for EC countries • Le illustrazioni sono riferite ai modelli CE / Pictures refer to CE approved models





MIXER A IMMERSIONE

stick blenders





UNA GAMMA COMPLETA PER LA SCELTA DEI PROFESSIONISTI

A FULL RANGE FOR
THE PROFESSIONAL'S CHOICE

MIXER A IMMERSIONE
SERIE HEAVYPRO
STICK BLENDERS
HEAVY DUTY PRO LINE

MIXER A IMMERSIONE
SERIE LIGHT
STICK BLENDERS
LIGHT DUTY LINE

MIXER A IMMERSIONE
SERIE LIGHT MINI
STICK BLENDERS
LIGHT DUTY LINE MINI





*MioMix*TM

MIXER HEAVY^{PRO}
MIXER LIGHT
MIXER LIGHT MINI

Serie Giò

Una gamma completa e funzionale,
adatta ad ogni tipo di lavorazione in cucina

Wide of range of processing tools to cover
all your processing needs



MESCOLATORE
BLENDER TUBE



EMULSIONATORE
EMULSIFIER TUBE

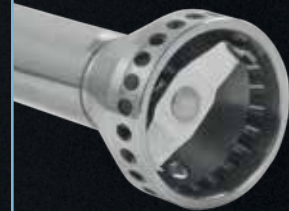

OMOGENEIZZATORE
HOMOGENIZER TUBE



MULTIFUNZIONE
MULTIPURPOSE TUBE



FRUSTA
WHISK

HEAVYPRO

LIGHT

MESCOLATORE BLENDER TUBE

Lame in acciaio INOX. Ideale per frullare zuppe di verdura, purè, salse, ecc.

Stainless steel blade. Ideal for blending vegetable soups, purees, sauces, etc



EMULSIONATORE EMULSIFIER TUBE

Disco in acciaio INOX. Ideale per emulsionare le salse, rendendole leggere e soffici

Stainless steel disc. Ideal for emulsifying sauces, making them light and soft



OMOGENEIZZATORE HOMOGENIZER TUBE

In acciaio INOX. Ideale per ottenere un prodotto liscio e setoso, grazie alla riduzione delle particelle fino a 2 micron

Made of stainless steel. Ideal for smoothing products as particles can be reduced down to 2 microns



MULTIFUNZIONE MULTIPURPOSE TUBE



Quadrilama in acciaio INOX. Trita, taglia e mescola in poco tempo. Ideale per la preparazione di gelati e glasse a specchio

Four-blade stainless steel knife. To chop, cut and mix effortlessly. Ideal for preparing ice cream and icing



FRUSTA WHISK

Con elementi interamente in Acciaio INOX, facilmente smontabili per una pulizia ottimale. Ideale per montare a neve (albumi d'uovo, panna, ecc.)

Stainless steel whisk, easy to remove for cleaning. Ideal for whipping (egg whites, cream, etc.)





MioMix™

SCEGLI IL TUO!
choose yours!

Dai 20 anni di esperienza di Fama sui mixer nasce Miomix. Prodotto completamente Made in Italy.

Miomix delivers Fama's 20 years expertise in hand mixer manufacturing. Made in Italy quality and design.

- Macchinario per uso professionale • Corpo realizzato in plastica con disegno innovativo • Macchinario dal peso contenuto e di facile utilizzo • Motore ventilato di produzione nazionale • Termica di protezione al motore • Variatore di velocità • Sistema elettronico di stabilizzazione di velocità e potenza SRS (self-regulating-speed) • Giunti di connessione in polimero ad alta resistenza • Accessori disponibili in due misure: 200-250 mm • Apparecchio certificato da ente di controllo • Norme CE • Fabbriato in Italia

- Professional equipment • Exclusive body design made from plastic • User friendly and light tool for comfortable use • Italian make ventilated motor • Thermal overload protection included • Variable speed • Control board equipped with SRS (self-regulating-speed) device for power and speed stabilization • High grade joints made from polymer • Accessories tubes available in 2 lengths: 200-250 mm • Patented machine • CE approved • Proudly Made in Italy



SRS Self-Regulating Speed

La tecnologia SRS consente di ottenere composti estremamente omogenei.

SRS device grants high-quality homogeneous mixtures.



CORPO MOTORE

BODY MOTOR

MIOMIX



Diametro corpo
Body diameter
Ø 75



Peso netto
Net weight (kg)
1,1 kg



Dimensioni prodotto
Product dimension (mm)
H. 285x75



COD. V



COD. B



COD. A



COD. R

	Codice Model code	Alimentazione Power supply (Volt/Hz)	Potenza Motor power (Watt)	Velocità/giri Speed (RPM)	Diametro corpo Diameter body	Peso netto Net weight (kg)	Dimensione prodotto Product dimension (mm)
Velocità variabile variable speed	MIOMIX*	230 / 50-60	250	2.500 max 15.000	Ø 75	1,1 kg	H. 290

*Ad ogni ordine, indicare la lettera del colore desiderato / Please mention colour code when ordering ● B ● R ● V ● A

COMPONENTI - MESCOLATORI

BLENDER TUBE

FM 200



Capacità
Capacity (lt)
1/15



Peso netto
Net weight (kg)
0,4 kg



Dimensioni prodotto
Product dimension (mm)
H. 220 / B. 75



FM 250



Capacità
Capacity (lt)
1/20



Peso netto
Net weight (kg)
0,45 kg



Dimensioni prodotto
Product dimension (mm)
H. 270 / B. 75



INOX



Codice
Model code

FM 200

Mescolatore 200 mm
Blender tube 200 mm

FM 250

Mescolatore 250 mm
Blender tube 250 mm

COMPONENTI - EMULSIONATORI

EMULSIFIER TUBE

FE 200



Capacità
Capacity (lt)
1/15



Peso netto
Net weight (kg)
0,4 kg



Dimensioni prodotto
Product dimension (mm)
H. 220 / B. 75



FE 250



Capacità
Capacity (lt)
1/20



Peso netto
Net weight (kg)
0,45 kg



Dimensioni prodotto
Product dimension (mm)
H. 270 / B. 75



INOX



Codice
Model code

FE 200

Emulsionatore 200 mm
Emulsifier tube 200 mm

FE 250

Emulsionatore 250 mm
Emulsifier tube 250 mm

COMPONENTI - FRUSTA

WHISK

FAFLM



Capacità
Capacity (lt)
10



Peso netto
Net weight (kg)
0,45 kg



Dimensioni prodotto
Product dimension (mm)
B. 290 / H. 90



INOX



Fruste in acciaio
inox smontabili
S/steel whisks that
can be dismantled

Codice
Model code

FAFLM

Frusta
Whisk

COMPONENTI - OMOGENEIZZATORI

HOMOGENIZER TUBE

FO 200



Capacità
Capacity (lt)
1/3



Peso netto
Net weight (kg)
0,35 kg



Dimensioni prodotto
Product dimension (mm)
H. 220 / B. 75



FO 250



Capacità
Capacity (lt)
1/5



Peso netto
Net weight (kg)
0,40 kg



Dimensioni prodotto
Product dimension (mm)
H. 270 / B. 75



Codice
Model code

FO 200

Omogeneizzatore 200 mm
Homogenizer tube 200 mm

FO 250

Omogeneizzatore 250 mm
Homogenizer tube 250 mm

COMPONENTI - MULTIFUNZIONE

MULTIPURPOSE TUBE

FMU 200



Capacità
Capacity (lt)
1/8



Peso netto
Net weight (kg)
0,36 kg



Dimensioni prodotto
Product dimension (mm)
H. 220 / B. 75



FMU 250



Capacità
Capacity (lt)
1/12



Peso netto
Net weight (kg)
0,40 kg



Dimensioni prodotto
Product dimension (mm)
H. 270 / B. 75



Codice
Model code

FMU 200

Multifunzione 200 mm
Multipurpose tube 200 mm

FMU 250

Multifunzione 250 mm
Multipurpose tube 250 mm

CARAFFA GRADUATA

GRADUATED JUG



Capacità
Capacity (lt)
1,5



Peso netto
Net weight (kg)
0,3 kg



Dimensioni prodotto
Product dimension (mm)
B. 120 / H. 190



Codice
Model code

F3557

Caraffa graduata
Graduated jug

FSPM
SUPPORTO PARETE SINGOLO MINI
SINGLE WALL SUPPORT



FSPCM
SUPPORTO PARETE PER COMBI MINI
WALL SUPPORT MINI FOR COMBI



MIOMIX TOPCHEF

Mixer Velocità Variabile 230V-50/60 Hz
+ Mescolatore 250 mm
+ Omogeneizzatore 250 mm
+ Multifunzione 250 mm
+ Frusta
+ Caraffa graduata
+ Supporto parete

Mixer Variable speed 230V-50/60 Hz
+ Blender Tube 250 mm
+ Homogenizer Tube 250 mm
+ Multipurpose Tube 250 mm
+ Whisk
+ Graduated jug
+ Wall support



Codice
Model code

Peso netto
Net Weight kg

Supporto parete singolo mini / Single wall support

FSPM

0,10

Supporto parete per combi mini / Wall support mini for combi

FSPCM

0,25

Miomix Top Chef / Miomix Top Chef

MIOMIX.TOPCHEF

4,3





MIXER A IMMERSIONE SERIE HEAVY PRO VELOCITÀ VARIABILE e VELOCITÀ FISSA

STICK BLENDERS HEAVY DUTY PRO LINE VARIABLE & FIXED SPEED

• Macchinario per uso professionale • Corpo motore in acciaio inox • Motore ventilato di produzione nazionale • Termica di protezione al motore • Impugnatura ergonomica per un maggiore comfort d'utilizzo • Display a cristalli liquidi • Regolatore a 9 velocità (solo velocità variabile) • Sistema elettronico di stabilizzazione di velocità e potenza SRS (self-regulating-speed) • Giunti di connessione in polimero ad alta resistenza • Mescolatore in acciaio inox disponibile in 4 lunghezze: 300-400-500-600 mm • Innesto mescolatore a vite • Apparecchio certificato da ente di controllo • Norme CE • Fabbriato in Italia

• Professional equipment • Stainless steel motor cover • Italian make ventilated motor • Thermal overload protection included • Ergonomic handle for comfortable use • Liquid crystal digital display • 9 speed regulator (only for variable speed) • Control board equipped with SRS (self-regulating-speed) device for power and speed stabilization • High grade joints made from polymer • Fully detachable stainless steel shafts available in 4 lengths: 300-400-500 and 600 mm • Tube screw fitting • Patented machine • CE approved • Proudly Made in Italy



**Pulsantiera
velocità variabile**

*Variable speed
models control
panel*



**Pulsantiera
velocità fissa**

*Fixed speed
models control
panel*



SRS Self-Regulating
Speed

La tecnologia SRS consente di ottenere
composti estremamente omogenei.

*SRS device grants high-quality
homogeneous mixtures.*

CORPO MOTORE - SERIE HEAVY^{PRO} VV / VF^{PRO}

BODY MOTOR HEAVY DUTY VV / VF PRO LINE

350



Diametro corpo
Body diameter
Ø 130



Peso netto
Net weight (kg)
2,6 kg



Dimensioni prodotto
Product dimension (mm)
H. 360



450



Diametro corpo
Body diameter
Ø 130



Peso netto
Net weight (kg)
3,2 kg



Dimensioni prodotto
Product dimension (mm)
H. 380



550



Diametro corpo
Body diameter
Ø 130



Peso netto
Net weight (kg)
3,4 kg



Dimensioni prodotto
Product dimension (mm)
H. 390



650



Diametro corpo
Body diameter
Ø 130



Peso netto
Net weight (kg)
3,6 kg



Dimensioni prodotto
Product dimension (mm)
H. 400



	Codice Model code	Alimentazione Power supply (Volt/Hz)	Potenza Motor power (Watt)	Velocità/giri Speed (RPM)	
Velocità variabile variable speed	FM350VV	230 / 50-60	350	2.000 - 9.000 max 15.000	
	FM450VV		450	2.000 - 11.000 max 17.000	
	FM550VV		550	2.000 - 9.000 max 15.000	
	FM650VV		650	2.000 - 9.000 max 13.000	
Velocità fissa fixed speed	FM350VF			350	15.000
	FM450VF			450	17.000
	FM550VF			550	15.000
	FM650VF			650	13.000

COMPONENTI - MESCOLATORI

SERIE HEAVY^{PRO} - VELOCITÀ VARIABILE E FISSA

BLENDER HEAVY DUTY PRO LINE - VARIABLE AND FIXED SPEED COMPONENTS

FM 300



Capacità
Capacity (lt)
30/80



Peso netto
Net weight (kg)
1,2 kg



Dimensioni prodotto
Product dimension (mm)
H. 330 / B. 95



FM 400



Capacità
Capacity (lt)
30/120



Peso netto
Net weight (kg)
1,45 kg



Dimensioni prodotto
Product dimension (mm)
H. 430 / B. 95



FM 500



Capacità
Capacity (lt)
30/230



Peso netto
Net weight (kg)
1,65 kg



Dimensioni prodotto
Product dimension (mm)
H. 530 / B. 95



FM 600



Capacità
Capacity (lt)
30/330



Peso netto
Net weight (kg)
1,9 kg



Dimensioni prodotto
Product dimension (mm)
H. 630 / B. 95



Codice
Model code

FM 300	Mescolatore 300 mm Blender tube 300 mm
FM 400	Mescolatore 400 mm Blender tube 400 mm
FM 500	Mescolatore 500 mm Blender tube 500 mm
FM 600	Mescolatore 600 mm Blender tube 600 mm



COMPONENTI - OMOGENEIZZATORI

SERIE HEAVY^{PRO} - VELOCITÀ VARIABILE E FISSA

HOMOGENIZER HEAVY DUTY PRO LINE - VARIABLE AND FIXED SPEED COMPONENTS

Nuovi omogeneizzatori:
riduzione dei globuli fino a 2 micron
New homogenizers:
reduce products up to two microns



Preparato con
mescolatore tradizionale
Processed with the standard
blending tube

FO 300



Capacità
Capacity (lt)
2/20



Peso netto
Net weight (kg)
1,2 kg



Dimensioni prodotto
Product dimension (mm)
H. 330 / B. 60



FO 400



Capacità
Capacity (lt)
2/30



Peso netto
Net weight (kg)
1,45 kg



Dimensioni prodotto
Product dimension (mm)
H. 430 / B. 60



FO 500



Capacità
Capacity (lt)
2/40



Peso netto
Net weight (kg)
1,7 kg



Dimensioni prodotto
Product dimension (mm)
H. 530 / B. 60



FO 600



Capacità
Capacity (lt)
2/50



Peso netto
Net weight (kg)
1,9 kg



Dimensioni prodotto
Product dimension (mm)
H. 630 / B. 60



Codice
Model code

FO 300	Omoogeneizzatore 300 mm Homogenizer tube 300 mm
FO 400	Omoogeneizzatore 400 mm Homogenizer tube 400 mm
FO 500	Omoogeneizzatore 500 mm Homogenizer tube 500 mm
FO 600	Omoogeneizzatore 600 mm Homogenizer tube 600 mm



COMPONENTI - MULTIFUNZIONE SERIE HEAVY^{PRO} - VELOCITÀ VARIABILE E FISSA

MULTIPURPOSE HEAVY DUTY PRO LINE - VARIABLE AND FIXED SPEED COMPONENTS

FMU 300



Capacità
Capacity (lt)
15/50



Peso netto
Net weight (kg)
1,2 kg



Dimensioni prodotto
Product dimension (mm)
H. 330 / B. 95



FMU 400



Capacità
Capacity (lt)
15/80



Peso netto
Net weight (kg)
1,45 kg



Dimensioni prodotto
Product dimension (mm)
H. 430 / B. 95



FMU 500



Capacità
Capacity (lt)
15/110



Peso netto
Net weight (kg)
1,7 kg



Dimensioni prodotto
Product dimension (mm)
H. 530 / B. 95



FMU 600



Capacità
Capacity (lt)
15/140



Peso netto
Net weight (kg)
1,9 kg



Dimensioni prodotto
Product dimension (mm)
H. 630 / B. 95



Codice
Model code

FMU 300	Multifunzione 300 mm Multipurpose tube 300 mm
FMU 400	Multifunzione 400 mm Multipurpose tube 400 mm
FMU 500	Multifunzione 500 mm Multipurpose tube 500 mm
FMU 600	Multifunzione 600 mm Multipurpose tube 600 mm

COMPONENTI - FRUSTA SERIE HEAVY^{PRO} - VELOCITÀ VARIABILE

WHISK HEAVY DUTY PRO LINE - ONLY VARIABLE SPEED COMPONENTS

FAF



Capacità
Capacity (lt)
80



Peso netto
Net weight (kg)
0,9 kg



Dimensioni prodotto
Product dimension (mm)
B. 120 / H. 360



INOX



Fruste in acciaio
inox smontabili
S/steel whisks that
can be dismantled

Codice
Model code

FAF	Frusta Whisk
-----	-----------------

CARATTERISTICHE MIXER HEAVY^{PRO} VV / VF

FEATURES MIXER HEAVY DUTY PRO LINE VV / VF MODEL



IMPUGNATURA ERGONOMICA
ERGONOMIC HANDLE



DISPLAY DIGITALE CON TASTO DI AVVIO (MODELLO VF)
DIGITAL DISPLAY WITH START BUTTON (VF MODEL)



REGOLATORE A 9 VELOCITÀ CON DISPLAY LUMINOSO (MODELLO VV)
LUMINOUS DISPLAY WITH 9 SPEEDS REGULATOR (VV MODEL)



CORPO CENTRALE IN ACCIAIO INOX PIÙ ROBUSTO E RESISTENTE
S/STEEL STURDY MAIN BLOCK



ESTREMA FACILITÀ DI CAMBIO ACCESSORI
EASY ACCESSORY CHANGING CLUTCH



BLOCCO GHIERA
NEW SLIDING JOINT LOCK



GIUNTO IN POLIMERO
POLYMER JOINT



ACCESSORI MIXER HEAVY^{PRO} VV / VF

ACCESSORIES MIXER HEAVY DUTY PRO LINE VV / VF MODEL



FSPS

SUPPORTO PARETE SINGOLO

SINGLE WALL SUPPORT



FSPC

SUPPORTO PARETE COMBI

WALL SUPPORT

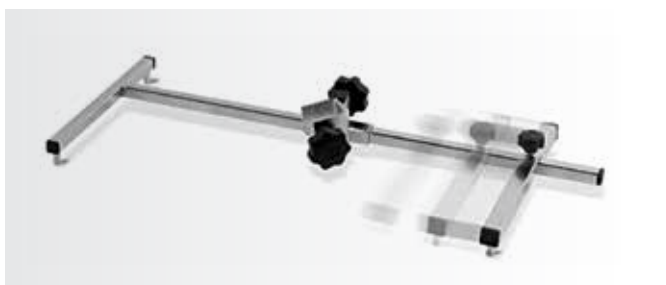

FSP

SUPPORTO PENTOLA REGOLABILE E CON SNODO LIBERO

ADJUSTABLE POT SUPPORT WITH FREE ARTICULATED JOINT

	Codice Model code	Peso netto Net Weight kg
Supporto parete singolo / Single wall support	FSPS	0,15
Supporto parete per mixer combi / Wall support for mixer combi	FSPC	0,30
Supporto pentola ø 400 mm / Pot support ø 400 mm	FSP400	1,95
Supporto pentola ø 600 mm / Pot support ø 600 mm	FSP600	2,15
Supporto pentola ø 800 mm / Pot support ø 800 mm	FSP800	2,35
Supporto pentola ø 1000 mm / Pot support ø 1000 mm	FSP1000	2,65
Supporto pentola ø 1200 mm / Pot support ø 1200 mm	FSP1200	2,75



MIXER A IMMERSIONE SERIE LIGHT 300 · 400 · 500 VELOCITÀ VARIABILE

STICK BLENDERS LIGHT
DUTY LINE 300 · 400 · 500
VARIABLE SPEED

- Macchinario per uso professionale • Corpo realizzato in plastica con disegno innovativo • Macchinario dal peso contenuto e di facile utilizzo • Motore ventilato di produzione nazionale • Termica di protezione al motore • Impugnatura ergonomica per un maggiore comfort d'utilizzo • Display a cristalli liquidi • Regolatore a 9 velocità • Sistema elettronico di stabilizzazione di velocità e potenza SRS (self-regulating-speed) • Giunti di connessione in polimero ad alta resistenza • Mescolatore disponibile in 3 misure: 300-400-500 mm • Innesto mescolatore a baionetta • Apparecchio certificato da ente di controllo • Norme CE • Fabbriato in Italia

- Professional equipment • Exclusive body design made from plastic • User friendly and light tool for comfortable use • Italian make ventilated motor • Thermal overload protection included • Ergonomic handle for comfortable use • Liquid crystal digital display • Variable speed • Control board equipped with SRS (self-regulating-speed) device for power and speed stabilization • High grade joints made from polymer • Fully detachable stainless steel shafts available in 3 lengths 300-400-500 mm • Tube bayonet fitting • Patented machine • CE approved • Proudly Made in Italy



SRS Self-Regulating Speed

La tecnologia SRS consente di ottenere composti estremamente omogenei.

SRS device grants high-quality homogeneous mixtures.

CORPO MOTORE - SERIE LIGHT VV

BODY MOTOR LIGHT DUTY VV LINE

300 VV



Diametro corpo
Body diameter
Ø 100



Peso netto
Net weight (kg)
1,8 kg



Dimensioni prodotto
Product dimension (mm)
H. 350



400 VV



Diametro corpo
Body diameter
Ø 100



Peso netto
Net weight (kg)
2,1 kg



Dimensioni prodotto
Product dimension (mm)
H. 350



500 VV



Diametro corpo
Body diameter
Ø 100



Peso netto
Net weight (kg)
2,4 kg



Dimensioni prodotto
Product dimension (mm)
H. 350



ACCESSORI

ACCESSORIES



mescolatore - *blender tube*



omogeneizzatore - *homogenizer tube*



frusta - *whisk*



multifunzione - *multipurpose tube*



	Codice Model code	Alimentazione Power supply (Volt/Hz)	Potenza Motor power (Watt)	Velocità/giri Speed (RPM)
Velocità variabile variable speed	FM300VV	230 / 50-60	300	2.000 - 9.000 max 13.000
	FM400VV		400	2.000 - 9.000 max 15.000
	FM500VV		500	2.000 - 9.000 max 15.000

COMPONENTI - MESCOLATORI

SERIE LIGHT 300 · 400 · 500 - VELOCITÀ VARIABILE

BLENDER LIGHT DUTY LINE 300 400 500 VARIABLE SPEED COMPONENTS

FM 300L



Capacità
Capacity (lt)
20/50



Peso netto
Net weight (kg)
0,85 kg



Dimensioni prodotto
Product dimension (mm)
H. 340 / B. 85



FM 400L



Capacità
Capacity (lt)
20/80



Peso netto
Net weight (kg)
1,0 kg



Dimensioni prodotto
Product dimension (mm)
H. 440 / B. 85



FM 500L



Capacità
Capacity (lt)
20/100



Peso netto
Net weight (kg)
1,2 kg



Dimensioni prodotto
Product dimension (mm)
H. 540 / B. 85



Codice
Model code

FM 300 L	Mescolatore 300 mm Blender tube 300 mm
FM 400 L	Mescolatore 400 mm Blender tube 400 mm
FM 500 L	Mescolatore 500 mm Blender tube 500 mm



COMPONENTI - OMOGENEIZZATORI

SERIE LIGHT 300 · 400 · 500 - VELOCITÀ VARIABILE

HOMOGENIZER LIGHT DUTY LINE 300 400 500 VARIABLE SPEED COMPONENTS

Nuovi omogeneizzatori:
riduzione dei globuli fino a 2 micron
New homogenizers:
reduce products up to two microns



Preparato con
mescolatore tradizionale
Processed with the standard
blending tube

FO 300L



Capacità
Capacity (lt)
2/10



Peso netto
Net weight (kg)
0,89 kg



Dimensioni prodotto
Product dimension (mm)
H. 340 / B. 55



FO 400L



Capacità
Capacity (lt)
2/20



Peso netto
Net weight (kg)
1,0 kg



Dimensioni prodotto
Product dimension (mm)
H. 440 / B. 55



FO 500L



Capacità
Capacity (lt)
2/30



Peso netto
Net weight (kg)
1,2 kg



Dimensioni prodotto
Product dimension (mm)
H. 540 / B. 55



Codice
Model code

FO 300L	Omoogeneizzatore 300 mm Homogenizer tube 300 mm
FO 400 L	Omoogeneizzatore 400 mm Homogenizer tube 400 mm
FO 500 L	Omoogeneizzatore 500 mm Homogenizer tube 500 mm



COMPONENTI - MULTIFUNZIONE

SERIE LIGHT 300 · 400 · 500 - VELOCITÀ VARIABILE

MULTIPURPOSE LIGHT DUTY LINE 300 400 500 VARIABLE SPEED COMPONENTS

FMU 300L



Capacità
Capacity (lt)
10/30



Peso netto
Net weight (kg)
0,85 kg



Dimensioni prodotto
Product dimension (mm)
H. 340 / B. 85



FMU 400L



Capacità
Capacity (lt)
10/50



Peso netto
Net weight (kg)
1,0 kg



Dimensioni prodotto
Product dimension (mm)
H. 440 / B. 85



FMU 500L



Capacità
Capacity (lt)
10/70



Peso netto
Net weight (kg)
1,2 kg



Dimensioni prodotto
Product dimension (mm)
H. 540 / B. 85



Codice
Model code

FMU 300L	Multifunzione 300 mm Multipurpose tube 300 mm
FMU 400L	Multifunzione 400 mm Multipurpose tube 400 mm
FMU 500L	Multifunzione 500 mm Multipurpose tube 500 mm

COMPONENTI - FRUSTA

SERIE LIGHT 300 · 400 · 500

VELOCITÀ VARIABILE

WHISK LIGHT DUTY LINE 300 400 500 VARIABLE SPEED COMPONENTS

FAFL



Capacità
Capacity (lt)
40



Peso netto
Net weight (kg)
0,8 kg



Dimensioni prodotto
Product dimension (mm)
B. 330 / H. 120



INOX



Fruste in acciaio inox smontabili
S/steel whisks that can be dismantled

Codice
Model code

FAFL	Frusta Whisk
------	-----------------

CARATTERISTICHE MIXER LIGHT

FEATURES MIXER LIGHT DUTY LINE 300 400 500 VV MODEL



**INNESTO A SGANCIO RAPIDO
CHE SEMPLIFICA L'INSERIMENTO
DEGLI ACCESSORI**

QUICK-AND-EASY CLUTCH



**PULSANTE IN DIMENSIONI
OTTIMALI. DISPLAY DIGITALE
CON REGOLATORE A 9 VELOCITÀ**

*HANDY STARTER. DIGITAL DISPLAY WITH
9 SPEEDS REGULATOR*



GIUNTO IN POLIMERO

POLYMER JOINT



ACCESSORI MIXER LIGHT

ACCESSORIES MIXER LIGHT DUTY LINE 300 400 500 VV MODEL



FSPC

SUPPORTO PARETE COMBI

WALL SUPPORT

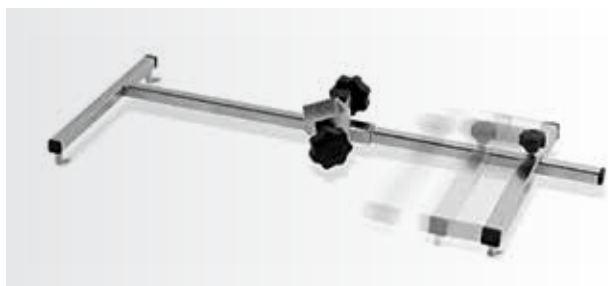

FSP

SUPPORTO PENTOLA REGOLABILE E CON SNODO LIBERO

ADJUSTABLE POT SUPPORT WITH FREE ARTICULATED JOINT



FMCG400

GELATO COMBI MIXER 400

GELATO COMBI MIXER 400

Mixer 400 Velocità Variabile 230V-50/60 Hz
+ Mescolatore da 400 mm
+ Omogeneizzatore 400 mm

Mixer 400 Variable Speed 230V-50/60 Hz
+ Blender tube 400 mm
+ Homogenizer tube 400 mm

	Codice Model code	Peso netto Net Weight kg
Supporto parete per mixer combi / Wall support for mixer combi	FSPC	0,30
Supporto pentola ø 400 mm / Pot support ø 400 mm	FSP 400	1,95
Supporto pentola ø 600 mm / Pot support ø 600 mm	FSP 600	2,15
Supporto pentola ø 800 mm / Pot support ø 800 mm	FSP 800	2,35
Supporto pentola ø 1000 mm / Pot support ø 1000 mm	FSP 1000	2,65
Supporto pentola ø 1200 mm / Pot support ø 1200 mm	FSP 1200	2,75
Gelato combi mixer 400 / Gelato combi mixer 400	FMCG 400	3,5



MIXER A IMMERSIONE SERIE LIGHT MINI 250 VELOCITÀ VARIABILE e VELOCITÀ FISSA

STICK BLENDERS LIGHT MINI DUTY LINE 250 VARIABLE AND FIXED SPEED

- Macchinario per uso professionale • Corpo realizzato in plastica con disegno innovativo • Macchinario dal peso contenuto e di facile utilizzo • Motore ventilato di produzione nazionale • Termica di protezione al motore • Variatore di velocità (solo nel modello VV) • Sistema elettronico di stabilizzazione di velocità e potenza SRS (self-regulating-speed) • Giunti di connessione in polimero ad alta resistenza • Mescolatori ed emulsionatori disponibili in due misure: 200-250 mm • Apparecchio certificato da ente di controllo • Norme CE • Fabbricato in Italia

- Professional equipment • Exclusive body design made from plastic • User friendly and light tool for comfortable use • Italian made ventilated motor • Thermal overload protection included • Variable speed (only model VV) • Control board equipped with SRS (self-regulating-speed) device for power and speed stabilization • High grade joints made from polymer • Blender and emulsifying tubes available in 2 lengths: 200-250 mm • Patented machine • CE approved • Proudly Made in Italy



La tecnologia SRS consente di ottenere
composti estremamente omogenei.

*SRS device grants high-quality
homogeneous mixtures.*

CORPO MOTORE - SERIE LIGHT MINI VV/ VF

BODY MOTOR LIGHT MINI DUTY VV / VF LINE

250 VF



Diametro corpo
Body diameter
Ø 75



Peso netto
Net weight (kg)
1,0 kg



Dimensioni prodotto
Product dimension (mm)
H. 285x75



250 VV



Diametro corpo
Body diameter
Ø 75



Peso netto
Net weight (kg)
1,0 kg



Dimensioni prodotto
Product dimension (mm)
H. 285x75



ACCESSORI

ACCESSORIES



mescolatore - *blender tube*

emulsionatore - *emulsifying tube*

frusta - *whisk*

omogeneizzatore - *homogenizer tube*

multifunzione - *multipurpose tube*



	Codice Model code	Alimentazione Power supply (Volt/Hz)	Potenza Motor power (Watt)	Velocità/giri Speed (RPM)
Velocità variabile / <i>variable speed</i>	FM250VV	230 / 50-60	250	2.500 max 15.000
Velocità fissa / <i>fixed speed</i>	FM250VF		250	15.000

COMPONENTI - MESCOLATORI

SERIE LIGHT MINI 250 VELOCITÀ FISSA E VELOCITÀ VARIABILE

BLENDER LIGHT MINI DUTY LINE 250 FIXED AND VARIABLE SPEED COMPONENTS

FM 200



Capacità
Capacity (lt)
1/15



Peso netto
Net weight (kg)
0,4 kg



Dimensioni prodotto
Product dimension (mm)
H. 220 / B. 75



FM 250



Capacità
Capacity (lt)
1/20



Peso netto
Net weight (kg)
0,45 kg



Dimensioni prodotto
Product dimension (mm)
H. 270 / B. 75



INOX



Codice
Model code

FM 200

Mescolatore 200 mm
Blender tube 200 mm

FM 250

Mescolatore 250 mm
Blender tube 250 mm

COMPONENTI - EMULSIONATORI

SERIE LIGHT MINI 250 VELOCITÀ VARIABILE

EMULSIFYING LIGHT MINI DUTY LINE 250 VARIABLE SPEED COMPONENTS

FE 200



Capacità
Capacity (lt)
1/15



Peso netto
Net weight (kg)
0,4 kg



Dimensioni prodotto
Product dimension (mm)
H. 220 / B. 75



FE 250



Capacità
Capacity (lt)
1/20



Peso netto
Net weight (kg)
0,45 kg



Dimensioni prodotto
Product dimension (mm)
H. 270 / B. 75



INOX



Codice
Model code

FE 200

Emulsionatore 200 mm
Emulsifying tube 200 mm

FE 250

Emulsionatore 250 mm
Emulsifying tube 250 mm

COMPONENTI - FRUSTA

SERIE LIGHT MINI 250 VELOCITÀ VARIABILE

WHISK LIGHT MINI DUTY LINE 250 VARIABLE SPEED COMPONENTS

FAFLM



Capacità
Capacity (lt)
10



Peso netto
Net weight (kg)
0,45 kg



Dimensioni prodotto
Product dimension (mm)
B. 290 / H. 90



INOX



Fruste in acciaio
inox smontabili
S/steel whisks that
can be dismantled

Codice
Model code

FAFLM

Frusta
Whisk

COMPONENTI - OMOGENEIZZATORI

SERIE LIGHT MINI 250 VELOCITÀ FISSA E VELOCITÀ VARIABILE

HOMOGENIZER LIGHT MINI DUTY LINE 250 FIXED AND VARIABLE SPEED COMPONENTS

FO 200



Capacità
Capacity (lt)
1/3



Peso netto
Net weight (kg)
0,35 kg



Dimensioni prodotto
Product dimension (mm)
H. 220 / B. 75



FO 250



Capacità
Capacity (lt)
1/5



Peso netto
Net weight (kg)
0,40 kg



Dimensioni prodotto
Product dimension (mm)
H. 270 / B. 75



Codice
Model code

FO 200	Omoogeneizzatore 200 mm Homogenizer tube 200 mm
FO 250	Omoogeneizzatore 250 mm Homogenizer tube 250 mm

COMPONENTI - MULTIFUNZIONE

SERIE LIGHT MINI 250 VELOCITÀ FISSA E VELOCITÀ VARIABILE

MULTIPURPOSE LIGHT MINI DUTY LINE 250 FIXED AND VARIABLE SPEED COMPONENTS

FMU 200



Capacità
Capacity (lt)
1/8



Peso netto
Net weight (kg)
0,36 kg



Dimensioni prodotto
Product dimension (mm)
H. 220 / B. 75



FMU 250



Capacità
Capacity (lt)
1/12



Peso netto
Net weight (kg)
0,40 kg



Dimensioni prodotto
Product dimension (mm)
H. 270 / B. 75



Codice
Model code

FMU 200	Multifunzione 200 mm Multipurpose tube 200 mm
FMU 250	Multifunzione 250 mm Multipurpose tube 250 mm



CARATTERISTICHE MIXER LIGHT MINI VV / VF

FEATURES MIXER LIGHT MINI DUTY LINE VV / VF MODEL



**ESTREMA FACILITÀ
DI SMONTAGGIO UTENSILE.
IMPUGNATURA ERGONOMICA**

*EASY ACCESSORY CHANGING CLUTCH.
ERGONOMIC HANDLE*



SEMPLICITÀ D'USO

USER FRIENDLY



**SOLO PER MIXER VV VARIATORE DI
VELOCITÀ**

ONLY VV MODEL SPEED VARIATOR



ACCESSORI MIXER LIGHT MINI VV / VF

ACCESSORIES LIGHT MINI DUTY LINE VV / VF MODEL



FSPM

SUPPORTO PARETE SINGOLO MINI

SINGLE WALL SUPPORT



FSPCM

SUPPORTO PARETE PER COMBI MINI

WALL SUPPORT MINI FOR COMBI





FMCG250
GELATO COMBI MIXER 250

Mixer Velocità Variabile 230V-50/60 Hz
+ Mescolatore da 250 mm
+ Omogeneizzatore 250 mm

*Mixer Variable speed 230V-50/60 Hz
+ Blender tube 250 mm
+ Homogenizer tube 250 mm*





FRULLUOTTO

Mixer Velocità Variabile 230V-50/60 Hz
+ Mescolatore da 250 mm
+ Omogeneizzatore 250 mm
+ Frusta

*Mixer Variable speed 230V-50/60 Hz
+ Blender tube 250 mm
+ Homogenizer tube 250 mm
+ Whisk*

	Codice Model code	Peso netto Net Weight kg
Supporto parete singolo mini / Single wall support	FSPM	0,10
Supporto parete per combi mini / Wall support mini for combi	FSPCM	0,25
Gelato combi mixer 250 / Gelato combi mixer 250	FMCG 250	2
Frullotto / Frullotto	FRULLUOTTO	2,5



AFFETTATRICI
slicing machines

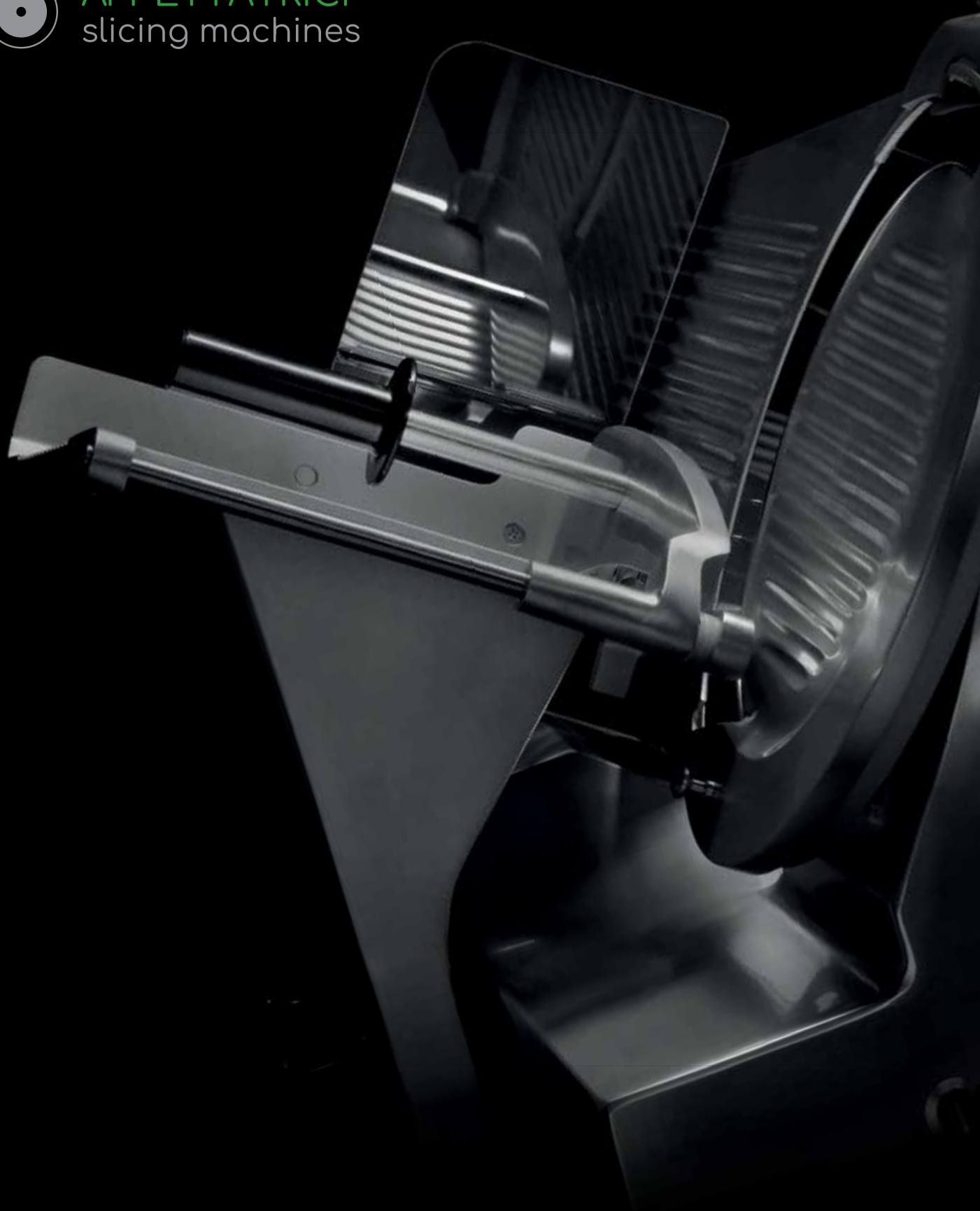

PRECISIONE E SICUREZZA
UNA SERIE DI GRANDE SPESSORE

ACCURACY AND SAFETY
A THICK SET

AFFETTATRICI GRAVITÀ
GRAVITY SLICERS

AFFETTATRICI GRAVITÀ LUXURY
LUXURY GRAVITY SLICERS

AFFETTATRICI VERTICALI
VERTICAL SLICERS

AFFETTATRICI VERTICALI LUXURY
LUXURY VERTICAL SLICERS

AFFETTACARNE
MEAT SLICER





AFFETTATRICI GRAVITÀ GRAVITY SLICERS

- Macchinario per uso professionale • Macchina realizzata in lega di alluminio anodizzato • Motore asincrono ventilato • Lama di produzione nazionale • Anello di protezione • Boccole carrello autolubrificanti • Protezione in plastica al carrello • Trasmissione a cinghia • Affilatoio incorporato • Facile da pulire • Curata nei dettagli • Norme CE • Fabbricata in Italia

- Professional equipment • Slicer made from highly polished anodised food-grade aluminium • Ventilated asynchronous motor • Italian made blades • Safety ring • Permanently lubricated carriage ball bearings • Safety carriage plastic cover • Belt transmission • Sharpening accessory included • Easy clean up • CE approved • Proudly Made in Italy



	Alimentazione Power supply (Volt/Hz)	Potenza Motor power (Kwatt/Hp)	Capacità di taglio Cutting capacity (mm)	Giri/m lama al minuto Blade revolution (RPM)	Corsa Carrello Carriage sliding (mm)	Spessore di taglio Slice thickness (mm)	Base d'appoggio affettatrice Slicer cutting area (mm)
220 ECO	230 / 50-60	0,18 (0,25)	190x160	300	240	0÷15	415x280
250 ECO		0,22 (0,30)	220x190		260		440x290
250	230/50	0,26 (0,35)	220x160		260	0÷16	470x310
275 ECO	230 / 50-60	0,22 (0,30)	220x220		260		440x290
300 ECO base piccola		0,24 (0,33)	220x210		270		440x290

220 GRAVITÀ ECO



Lama
Blade size (mm)
Ø 220



Peso netto
Net weight (kg)
13,5 kg



Dimensioni prodotto
Product dimension (mm)
D. 450 / B. 450 / H. 370



250 GRAVITÀ ECO



Lama
Blade size (mm)
Ø 250



Peso netto
Net weight (kg)
15,5 kg



Dimensioni prodotto
Product dimension (mm)
D. 490 / B. 430 / H. 400



250 GRAVITÀ



Lama
Blade size (mm)
Ø 250



Peso netto
Net weight (kg)
16,0 kg



Dimensioni prodotto
Product dimension (mm)
D. 510 / B. 430 / H. 390



275 GRAVITÀ ECO



Lama
Blade size (mm)
Ø 275



Peso netto
Net weight (kg)
17,0 kg



Dimensioni prodotto
Product dimension (mm)
D. 500 / B. 430 / H. 410



300 GRAVITÀ ECO BASE PICCOLA



Lama
Blade size (mm)
Ø 300



Peso netto
Net weight (kg)
19,0 kg



Dimensioni prodotto
Product dimension (mm)
D. 490 / B. 470 / H. 340



	NORME CE CE APPROVED	SENZA NORME CE NON CE APPROVED
220 ECO 230V monofase single phase codice prodotto product code	FAF223	FAF223E
250 ECO 230V monofase single phase codice prodotto product code	FAFG253	FAFG253E
250 230V monofase single phase codice prodotto product code	FA253	FA253E
275 ECO 230V monofase single phase codice prodotto product code	FAF279	FAF279E
300 ECO BASE PICCOLA 230V monofase single phase codice prodotto product code	FAF303	FAF303E



AFFETTATRICI GRAVITÀ LUXURY LUXURY GRAVITY SLICER

- Macchinario per uso professionale • Fusione in lega di alluminio anodizzato • Motore asincrono ventilato • Lama tornita di produzione nazionale • Anello di protezione alla lama • Boccole carrello autolubrificanti • Blocco al carrello • Protezione al carrello in plastica • Supporto vela maggiorato • Ampio piatto porta salumi • Scheda elettrica a 24 volt • Trasmissione a cinghia in poliestere • Affilatoio incorporato • Facile da pulire • Curata nei dettagli • Norme CE • Fabbricata in Italia

- Professional equipment • Anodised food-grade aluminium • Ventilated asynchronous motor • Italian make turned blade • Blade safety ring • Permanently lubricated carriage ball bearings • CE approved carriage locking • Safety carriage plexiglass cover • Capacious feeding pan • 24 Low tension card included • High quality gravity feed slicer • Powerful polyester belt driven transmission • Sharpening accessory included • Easy clean up • CE approved • Proudly Made in Italy



Alimentazione Power supply (Volt/Hz)	Potenza Motor power (Kwatt/Hp)	Capacità di taglio Cutting capacity (mm)	Giri/m lama al minuto Blade revolution (RPM)	Corsa Carrello Carriage sliding (mm)	Spessore di taglio Slice thickness (mm)	Base d'appoggio affettatrice Slicer cutting area (mm)
---	-----------------------------------	---	---	---	--	---

LUXURY 275	230/50 230-400/50	0,27 (0,36)	230x160	300	270	470x320
LUXURY 300			250x190	280		
LUXURY 330	230-400/50	0,38 (0,50)	240x250	280	330	600x420
LUXURY 350			320x230	260		

275 LUXURY



Lama
Blade size (mm)
Ø 275



Peso netto
Net weight (kg)
22,0 kg



Dimensioni prodotto
Product dimension (mm)
D. 640 / B. 490 / H. 460



300 LUXURY



Lama
Blade size (mm)
Ø 300



Peso netto
Net weight (kg)
23,0 kg



Dimensioni prodotto
Product dimension (mm)
D. 640 / B. 490 / H. 460



330 LUXURY



Lama
Blade size (mm)
Ø 330



Peso netto
Net weight (kg)
38,0 kg



Dimensioni prodotto
Product dimension (mm)
D. 760 / B. 540 / H. 510



350 LUXURY



Lama
Blade size (mm)
Ø 350



Peso netto
Net weight (kg)
39,0 kg



Dimensioni prodotto
Product dimension (mm)
D. 780 / B. 540 / H. 510



	NORME CE / CE APPROVED	SENZA NORME CE / NON CE APPROVED
275 B300 230/400V trifase <i>three phase</i> codice prodotto <i>product code</i>	FA278	FA278E
275 B300 230V monofase <i>single phase</i> codice prodotto <i>product code</i>	FA277	FA277E
300 230/400V trifase <i>three phase</i> codice prodotto <i>product code</i>	FA302	FA302E
300 230V monofase <i>single phase</i> codice prodotto <i>product code</i>	FA303	FA303E
330 230/400V trifase <i>three phase</i> codice prodotto <i>product code</i>	FA332	FA332E
330 230V monofase <i>single phase</i> codice prodotto <i>product code</i>	FA333	FA333E
350 230/400V trifase <i>three phase</i> codice prodotto <i>product code</i>	FA352	FA352E
350 230V monofase <i>single phase</i> codice prodotto <i>product code</i>	FA353	FA353E



AFFETTATRICI VERTICALI

VERTICAL SLICERS

- Macchinario per uso professionale • Fusione in lega di alluminio anodizzato • Lama forgiata in acciaio temperato • Anello di protezione alla lama • Motore asincrono ventilato • Boccole carrello autolubrificanti • Blocco al carrello • Scorrevole piatto porta salumi con braccio a cigno • Trasmissione a cinghia in poliestere • Affilatoio incorporato • Facile da pulire • Curata nei dettagli • Norme CE • Fabbricata in Italia

- Professional equipment • Anodised food-grade aluminium • Forged and hardened blade • Blade safety ring • Ventilated asynchronous motor with thermal protection • Permanently lubricated carriage ball bearings • CE approved carriage locking • Swan shaped clamp lever • Polyester Belt transmission • Sharpening accessory included • Easy clean up • CE approved • Proudly Made in Italy



300



Lama
Blade size (mm)
Ø 300



Peso netto
Net weight (kg)
24,0 kg



Dimensioni prodotto
Product dimension (mm)
D. 820 / B. 650 / H. 640

	Alimentazione Power supply (Volt/Hz)	Potenza Motor power (Kwatt/Hp)	Capacità di taglio Cutting capacity (mm)	Giri/m lama al minuto Blade revolution (RPM)	Corsa Carrello Carriage sliding (mm)	Spessore di taglio Slice thickness (mm)	Base d'appoggio affettatrice Slicer cutting area (mm)
300	230/50 230-400/5	0,30 (0,40)	270x190	280	300	0÷15	470x350

	NORME CE / CE APPROVED	SENZA NORME CE / NON CE APPROVED
300 230/400V trifase three phase codice prodotto product code	FA300	FA300E
300 230V monofase single phase codice prodotto product code	FA301	FA301E

• I macchinari senza norme CE sono destinati ai paesi fuori dalla Comunità Europea / Not suitable for EC countries • Le illustrazioni sono riferite ai modelli CE / Pictures refer to CE approved models





AFFETTATRICI VERTICALI LUXURY

LUXURY VERTICAL SLICERS

• Macchinario per uso professionale • Fusione in lega di alluminio anodizzato • Lama forgiata in acciaio temperato • Anello di protezione alla lama • Motore asincrono ventilato • Boccole carrello autolubrificanti • Blocco al carrello • Scorrevole piatto porta salumi con braccio a cigno • Trasmissione a cinghia in poliestere • Affilatoio incorporato • Facile da pulire • Curata nei dettagli • Norme CE • Fabbricata in Italia

• Professional equipment • Anodised food-grade aluminium • Forged and hardened blade • Blade safety ring • Ventilated asynchronous motor with thermal protection • Permanently lubricated carriage ball bearings • CE approved carriage locking • Swan shaped clamp lever • Polyester Belt transmission • Sharpening accessory included • Easy clean up • CE approved • Proudly Made in Italy



	Alimentazione Power supply (Volt/Hz)	Potenza Motor power (Kwatt/Hp)	Capacità di taglio Cutting capacity (mm)	Giri/m lama al minuto Blade revolution (RPM)	Corsa Carrello Carriage sliding (mm)	Spessore di taglio Slice thickness (mm)	Base d'appoggio affettatrice Slicer cutting area (mm)
LUXURY 330	230/50 230-400/50	0,38 (0,50)	340	280	340	0÷16	605x445
LUXURY 350			390	260	390		605x445
LUXURY 370			420		420		610x460

330 LUXURY



Lama
Blade size (mm)
Ø 330



Peso netto
Net weight (kg)
40,0 kg



Dimensioni prodotto
Product dimension (mm)
D. 690 / B. 620 / H. 520



350 LUXURY



Lama
Blade size (mm)
Ø 350



Peso netto
Net weight (kg)
45,0 kg



Dimensioni prodotto
Product dimension (mm)
D. 710 / B. 640 / H. 540



370 LUXURY



Lama
Blade size (mm)
Ø 370



Peso netto
Net weight (kg)
47,0 kg



Dimensioni prodotto
Product dimension (mm)
D. 770 / B. 650 / H. 580



	NORME CE / CE APPROVED	SENZA NORME CE / NON CE APPROVED
330 230/400V trifase three phase codice prodotto product code	FA330	
330 230V monofase single phase codice prodotto product code	FA331	
350 230/400V trifase three phase codice prodotto product code	FA350	
350 230V monofase single phase codice prodotto product code	FA351	
370 230/400V trifase three phase codice prodotto product code	FA370	
370 230V monofase single phase codice prodotto product code	FA371	



AFFETTACARNE MEAT SLICER

- Macchinario per uso professionale • Robusta fusione di lega di alluminio alimentare anodizzato • Lama forgiata e temprata • Motore asincrono ventilato • Grande capacità di taglio • Boccole carrello autolubrificanti • Blocco al carrello • Ampio piatto porta carne • Braccio stringi carne a cigno • Trasmissione a cinghia • Interruttore digitale • Scheda a 24 volt • Affilatoio incorporato • Curata nei dettagli • Norme CE • Fabbricato in Italia

- Professional equipment • Heavy duty slicer made from highly polished anodised food-grade aluminium • Forged and hardened blade • Ventilated asynchronous motor • Wide cutting capacity • Permanently lubricated carriage ball bearings • CE models with carriage locking option • Large product support • Swan shaped clamp lever • Belt transmission • Digital ON/OFF switch • 24 Low tension card included • Sharpener included • CE approved • Proudly Made in Italy



	Alimentazione Power supply (Volt/Hz)	Potenza Motor power (Kwatt/Hp)	Capacità di taglio Cutting capacity (mm)	Giri/m lama al minuto Blade revolution (RPM)	Corsa Carrello Carriage sliding (mm)	Spessore di taglio Slice thickness (mm)	Base d'appoggio affettatrice Slicer cutting area (mm)
300	230/50 230-400/50	0,27 (0,36)	270x190	280	300	0÷16	495x360
350		0,38 (0,50)	300x245	260	340		605x445
370			340x255		400		610x460

300



Lama
Blade size (mm)
Ø 300



Peso netto
Net weight (kg)
35,0 kg



Dimensioni prodotto
Product dimension (mm)
D. 640 / B. 530 / H. 500



350



Lama
Blade size (mm)
Ø 350



Peso netto
Net weight (kg)
43,0 kg



Dimensioni prodotto
Product dimension (mm)
D. 740 / B. 750 / H. 550



370



Lama
Blade size (mm)
Ø 370



Peso netto
Net weight (kg)
46,0 kg



Dimensioni prodotto
Product dimension (mm)
D. 750 / B. 750 / H. 570



NORME CE / CE APPROVED

AFFETTACARNE 300 230/400V trifase *three phase*
codice prodotto *product code*

FAC300

AFFETTACARNE 300 230V monofase *single phase*
codice prodotto *product code*

FAC301

AFFETTACARNE 350 230/400V trifase *three phase*
codice prodotto *product code*

FAC350

AFFETTACARNE 350 230V monofase *single phase*
codice prodotto *product code*

FAC351

AFFETTACARNE 370 230/400V trifase *three phase*
codice prodotto *product code*

FAC370

AFFETTACARNE 370 230V monofase *single phase*
codice prodotto *product code*

FAC371



PREPARAZIONE DINAMICA

dynamic processing





TUTTO PRONTO
IN BREVISSIMO TEMPO

EVERYTHING READY
IN THE TWINKLING OF AN EYE

PELAPATATE
POTATO PEELER

PULISCICOZZE
MUSSEL WASHER

LAVATARTUFO
TRUFFLE WASHER

TAGLIAVERDURE ÉLITE
ÉLITE VEGETABLE CUTTER

CUTTER
CUTTER

TAGLIAMOZZARELLA
MOZZARELLA CHEESE CUTTER





PELATATE SERIE 5 kg POTATO PEELER 5 kg RANGE

- Macchinario per uso professionale • Struttura completamente in acciaio inossidabile AISI 304 • Motore asincrono ventilato di produzione nazionale
- Pareti abrasive facilmente sostituibili senza l'utilizzo di attrezzi • Elettrovalvola elettronica per ingresso acqua • Micro al coperchio e sportello
- Coperchio in plastica trasparente infrangibile • Coperchio in acciaio inox (a richiesta) • Cassette filtro allo scarico di serie • Visibili e pratici comandi digitali • Apparato elettrico esterno protetto da scatola di plastica isolata • Timer digitale multifunzione • Pulsante manuale per scarico prodotto • Collettore di scarico a terra o parete • Trasmissione a cinghia
- Norme CE • Fabbriato in Italia

- Professional equipment • Entirely structured in AISI 304 s/steel • Ventilated asynchronous Italian make motor • Abrasives designed to enable the user to operate, clean and maintain with the minimum of effort • Water jets electronic valve • Safety micro switch assembled on the cover and chute
- Unbreakable transparent plastic cover • Waste filter drawer included • Digital and user-friendly control panel • Electric parts covered by safety ergonomic plastic case • Multifunction digital timer • Manual discharge button • Wall or floor discharge outlet • Belt transmission • CE approved • Proudly Made in Italy



Alimentazione
Power supply (Volt/Hz)

Potenza
Motor power (Kwatt/
Hp)

Giri piatto
Peeler dish
revolutions (RPM)

Produzione oraria
Production per hour
(kg/h)

Tempo ciclo
pulitura
Peeling cycle (sec)

Carico massimo
Maximum charge (kg)

Temperatura acqua
Water
temperature (°C)

Alimentazione tubo
flessibile
Flexible pipe feeding
(inch)

Collettore scarico
laterale
Side discharge
manifold (mm)

5 KG

230/50 230-400/50

0,37 (0,50)

270

150

60-90

5

5-20

3/4

ø50

DA BANCO

BENCHTOP MODEL



Collettore scarico laterale
Side discharge manifold (mm)
Ø 50



Peso netto
Net weight (kg)
26,0 kg



Dimensioni prodotto
Product dimension (mm)
B. 530 / D. 530 / H. 530

Dimensione imballo
Packing dimensions (mm)
B. 600 / D. 660 / H. 740



CON PIEDI

WITH BLACK LEGS



Collettore scarico inferiore
Lower discharge manifold (mm)
Ø 50



Peso netto
Net weight (kg)
30,0 kg



Dimensioni prodotto
Product dimension (mm)
B. 530 / D. 530 / H. 660

Dimensione imballo
Packing dimensions (mm)
B. 600 / D. 660 / H. 800



SUPPORTO STANDARD

CON CASSETTO E FILTRO INCLUSO
INCLUSIVE OF WASTE FILTER DRAWER



Collettore scarico inferiore
Lower discharge manifold (mm)
Ø 40



Peso netto
Net weight (kg)
34,0 kg



Dimensioni prodotto
Product dimension (mm)
B. 530 / D. 530 / H. 720

Dimensione imballo
Packing dimensions (mm)
B. 660 / D. 600 / H. 800



SUPPORTO ALTO

CON CASSETTO E FILTRO INCLUSO
WITH HIGH STAND INCLUSIVE OF WASTE FILTER DRAWER



Collettore scarico inferiore
Lower discharge manifold (mm)
Ø 50



Peso netto
Net weight (kg)
38,0 kg



Dimensioni prodotto
Product dimension (mm)
B. 530 / D. 530 / H. 970

Dimensione imballo
Packing dimensions (mm)
B. 600 / D. 660 / H. 1020



	NORME CE / CE APPROVED		SENZA NORME CE / NON CE APPROVED	
	Trifase / Three phase V. 230/400	Monofase / Single phase V. 230	Trifase / Three phase V. 230/400	Monofase / Single phase V. 230
5 KG BANCO 0,37 Kw (0,50 Hp) codice prodotto product code	FP105	FP104	FP105E	FP104E
5 KG CON PIEDI 0,37 Kw (0,50 Hp) codice prodotto product code	FP107P	FP106P	FP107PE	FP106PE
5 KG SUPPORTO STANDARD 0,37 Kw (0,50 Hp) codice prodotto product code	FP107	FP106	FP107E	FP106E
5 KG SUPPORTO ALTO 0,37 Kw (0,50 Hp) codice prodotto product code	FP109	FP108	FP109E	FP108E
CI supplemento per coperchio inox optional for stainless steel lid	su richiesta / on request		su richiesta / on request	
CF cassetto e filtro optional for drawer-filter	di serie / included		La versione non CE di base non prevede cassetto e filtro Non Ce approved model is not inclusive of waste filter drawer	



PELATATE SERIE 10 kg POTATO PEELER 10 kg RANGE

• Macchinario per uso professionale • Struttura completamente in acciaio inossidabile AISI 304 • Motore asincrono ventilato di produzione nazionale • Pareti abrasive facilmente sostituibili senza l'utilizzo di attrezzi • Elettrovalvola elettronica per ingresso acqua • Micro al coperchio e sportello • Coperchio in plastica trasparente infrangibile • Coperchio in acciaio inox (a richiesta) • Cassetto filtro allo scarico di serie • Visibili e pratici comandi digitali • Apparato elettrico esterno protetto da scatola di plastica isolata • Timer digitale multifunzione • Pulsante manuale per scarico prodotto • Collettore di scarico a terra o parete • Trasmissione a cinghia • Norme CE • Fabbriato in Italia

• Professional equipment • Entirely structured in AISI 304 s/steel • Ventilated asynchronous Italian make motor • Abrasives designed to enable the user to operate, clean and maintain with the minimum of effort • Water jets electronic valve • Safety micro switch assembled on the cover and chute • Unbreakable transparent plastic cover • Waste filter drawer included • Digital and user-friendly control panel • Electric parts covered by safety ergonomic plastic case • Multifunction digital timer • Manual discharge button • Wall or floor discharge outlet • Belt transmission • CE approved • Proudly Made in Italy



Alimentazione
Power supply (Volt/Hz)

Potenza
Motor power
(Kwatt/HP)

Giri piatto
Peeler dish
revolutions (RPM)

Produzione oraria
Production per hour
(kg/h)

Tempo ciclo
pulitura
Peeling cycle (sec)

Carico massimo
Maximum charge (kg)

Temperatura acqua
Water
temperature (°C)

Alimentazione tubo
flessibile
Flexible pipe feeding
(inch)

Collettore scarico
laterale
Side discharge
manifold (mm)

10 KG

230/50 230-400/50

0,55 (0,75)

320

300

90-120

10

5-20

3/4

ø50

CON PIEDI

WITH BLACK LEGS



Collettore scarico inferiore
Lower discharge manifold (mm)
Ø 50



Peso netto
Net weight (kg)
35,0 kg



Dimensioni prodotto
Product dimension (mm)
B. 530 / D. 670 / H. 790

Dimensione imballo
Packing dimensions (mm)
B. 600 / D. 660 / H. 920



SUPPORTO STANDARD

CON CASSETTO E FILTRO INCLUSO

INCLUSIVE OF WASTE FILTER DRAWER



Collettore scarico inferiore
Lower discharge manifold (mm)
Ø 40



Peso netto
Net weight (kg)
39,0 kg



Dimensioni prodotto
Product dimension (mm)
B. 530 / D. 670 / H. 850

Dimensione imballo
Packing dimensions (mm)
B. 600 / D. 660 / H. 920



SUPPORTO ALTO

CON CASSETTO E FILTRO INCLUSO

WITH HIGH STAND INCLUSIVE OF WASTE FILTER DRAWER



Collettore scarico inferiore
Lower discharge manifold (mm)
Ø 50



Peso netto
Net weight (kg)
43,0 kg



Dimensioni prodotto
Product dimension (mm)
B. 530 / D. 670 / H. 1100

Dimensione imballo
Packing dimensions (mm)
B. 600 / D. 660 / H. 1130



	NORME CE / CE APPROVED		SENZA NORME CE / NON CE APPROVED	
	Trifase / Three phase V. 230/400	Monofase / Single phase V. 230	Trifase / Three phase V. 230/400	Monofase / Single phase V. 230
10 KG CON PIEDI 0,55 Kw (0,75 Hp) codice prodotto product code	FP101P	FP100P	FP101PE	FP100PE
10 KG SUPPORTO STANDARD 0,55 Kw (0,75 Hp) codice prodotto product code	FP101	FP100	FP101E	FP100E
10 KG SUPPORTO ALTO 0,55 Kw (0,75 Hp) codice prodotto product code	FP111	FP110	FP111E	FP110E
CI supplemento per coperchio inox optional for stainless steel lid	su richiesta / on request		su richiesta / on request	
CF cassetto e filtro optional for drawer-filter	di serie / included		La versione non CE di base non prevede cassetto e filtro Non Ce approved model is not inclusive of waste filter drawer	

• I macchinari senza norme CE sono destinati ai paesi fuori dalla Comunità Europea / Not suitable for EC countries • Le illustrazioni sono riferite ai modelli CE / Pictures refer to CE approved models



PELATATATE SERIE 18 kg POTATO PEELER 18 kg RANGE

- Macchinario per uso professionale • Struttura completamente in acciaio inossidabile AISI 304 • Motore asincrono ventilato di produzione nazionale
- Pareti abrasive facilmente sostituibili senza l'utilizzo di attrezzi • Elettrovalvola elettronica per ingresso acqua • Micro al coperchio e sportello
- Coperchio in plastica trasparente infrangibile • Coperchio in acciaio inox (a richiesta) • Cassetto filtro allo scarico di serie • Visibili e pratici comandi digitali • Apparato elettrico esterno protetto da scatola di plastica isolata • Timer digitale multifunzione • Pulsante manuale per scarico prodotto • Collettore di scarico a terra o parete • Trasmissione a cinghia
- Norme CE • Fabbriato in Italia

- Professional equipment • Entirely structured in AISI 304 s/steel • Ventilated asynchronous Italian make motor • Abrasives designed to enable the user to operate, clean and maintain with the minimum of effort • Water jets electronic valve • Safety micro switch assembled on the cover and chute • Unbreakable transparent plastic cover • Waste filter drawer included • Digital and user-friendly control panel • Electric parts covered by safety ergonomic plastic case • Multifunction digital timer • Manual discharge button • Wall or floor discharge outlet • Belt transmission • CE approved • Proudly Made in Italy



Alimentazione
Power supply (Volt/Hz)

Potenza
Motor power
(Kwatt/Hp)

Giri piatto
Peeler dish
revolutions (RPM)

Produzione oraria
Production per hour
(kg/h)

Tempo ciclo
pulitura
Peeling cycle (sec)

Carico massimo
Maximum charge (kg)

Temperatura acqua
Water
temperature (°C)

Alimentazione tubo
flessibile
Flexible pipe feeding
(inch)

Collettore scarico
laterale
Side discharge
manifold (mm)

18 KG

230/50 230-400/50

0,90 (1,20)

320

500

120-150

18

5-20

3/4

ø50

CON PIEDI

WITH BLACK LEGS



Collettore scarico inferiore
Lower discharge manifold (mm)
Ø 50



Peso netto
Net weight (kg)
39,0 kg



Dimensioni prodotto
Product dimension (mm)
B. 530 / D. 670 / H. 890

Dimensione imballo
Packing dimensions (mm)
B. 600 / D. 660 / H. 1020



SUPPORTO STANDARD

CON CASSETTO E FILTRO INCLUSO

INCLUSIVE OF WASTE FILTER DRAWER



Collettore scarico inferiore
Lower discharge manifold (mm)
Ø 40



Peso netto
Net weight (kg)
44,0 kg



Dimensioni prodotto
Product dimension (mm)
B. 530 / D. 670 / H. 950

Dimensione imballo
Packing dimensions (mm)
B. 600 / D. 660 / H. 1020



SUPPORTO ALTO

CON CASSETTO E FILTRO INCLUSO

WITH HIGH STAND INCLUSIVE OF WASTE FILTER DRAWER



Collettore scarico inferiore
Lower discharge manifold (mm)
Ø 50



Peso netto
Net weight (kg)
47,0 kg



Dimensioni prodotto
Product dimension (mm)
B. 530 / D. 670 / H. 1200

Dimensione imballo
Packing dimensions (mm)
B. 600 / D. 660 / H. 1270



	NORME CE / CE APPROVED		SENZA NORME CE / NON CE APPROVED	
	Trifase / Three phase V. 230/400	Monofase / Single phase V. 230	Trifase / Three phase V. 230/400	Monofase / Single phase V. 230
18 KG CON PIEDI 0,90 Kw (1,2 Hp) <i>codice prodotto product code</i>	FP103P	FP102P	FP103PE	FP102PE
18 KG SUPPORTO STANDARD 0,90 Kw (1,2 Hp) <i>codice prodotto product code</i>	FP103	FP102	FP103E	FP102E
18 KG SUPPORTO ALTO 0,90 Kw (1,2 Hp) <i>codice prodotto product code</i>	FP113	FP112	FP113E	FP112E
CI supplemento per coperchio inox <i>optional for stainless steel lid</i>	su richiesta / on request		su richiesta / on request	
CF cassetto e filtro <i>optional for drawer-filter</i>	di serie / included		La versione non CE di base non prevede cassetto e filtro	Non Ce approved model is not inclusive of waste filter drawer

• I macchinari senza norme CE sono destinati ai paesi fuori dalla Comunità Europea / Not suitable for EC countries • Le illustrazioni sono riferite ai modelli CE / Pictures refer to CE approved models



PELATATATE SERIE 30 kg POTATO PEELER 30 kg RANGE

- Macchinario per uso professionale • Struttura completamente in acciaio inossidabile AISI 304 • Motore asincrono ventilato di produzione nazionale
- Pareti abrasive facilmente sostituibili senza l'utilizzo di attrezzi • Elettrovalvola elettronica per ingresso acqua • Micro al coperchio e sportello
- Coperchio in acciaio inox con oblò • Cassetto filtro allo scarico di serie
- Visibili e pratici comandi digitali • Apparato elettrico esterno protetto da scatola di plastica isolata • Timer digitale multifunzione • Pulsante manuale per scarico prodotto • Collettore di scarico a terra o parete • Trasmissione a cinghia • Norme CE • Fabbriato in Italia

- Professional equipment • Entirely structured in AISI 304 s/steel • Ventilated asynchronous Italian make motor • Abrasives designed to enable the user to operate, clean and maintain with the minimum of effort • Water jets electronic valve • Safety micro switch assembled on the cover and chute
- Stainless steel lid with porthole window • Waste filter drawer included • Digital and user-friendly control panel • Electric parts covered by safety ergonomic plastic case • Multifunction digital timer • Manual discharge button • Wall or floor discharge outlet • Belt transmission • CE approved • Proudly Made in Italy



Coperchio in acciaio INOX 30 KG
30 KG Stainless Steel lid
Di serie / Included

Alimentazione Power supply (Volt/Hz)	Potenza Motor power (Kwatt/Hp)	Giri piatto Peeler dish revolutions (RPM)	Produzione oraria Production per hour (kg/h)	Tempo ciclo pulitura Peeling cycle (sec)	Carico massimo Maximum charge (kg)	Temperatura acqua Water temperature (°C)	Alimentazione tubo flessibile Flexible pipe feeding (inch)	Collettore scarico laterale Side discharge manifold (mm)
---	--------------------------------------	---	--	--	---------------------------------------	--	---	---

30 KG	230/50 230-400/50	0,96 (1,30)	240	700	120-150	30	5-20	3/4	ø50
--------------	-------------------	-------------	-----	-----	---------	----	------	-----	-----

CON PIEDI

WITH BLACK LEGS



Collettore scarico inferiore
Lower discharge manifold (mm)
Ø 50



Peso netto
Net weight (kg)
53,0 kg



Dimensioni prodotto
Product dimension (mm)
B. 640 / D. 780 / H. 910

Dimensione imballo
Packing dimensions (mm)
B. 700 / D. 800 / H. 1050



SUPPORTO STANDARD

CON CASSETTO E FILTRO INCLUSO
INCLUSIVE OF WASTE FILTER DRAWER



Collettore scarico inferiore
Lower discharge manifold (mm)
Ø 40



Peso netto
Net weight (kg)
61,0 kg



Dimensioni prodotto
Product dimension (mm)
B. 640 / D. 780 / H. 970

Dimensione imballo
Packing dimensions (mm)
B. 700 / D. 800 / H. 1050



SUPPORTO ALTO

CON CASSETTO E FILTRO INCLUSO
WITH HIGH STAND INCLUSIVE OF WASTE FILTER DRAWER



Collettore scarico inferiore
Lower discharge manifold (mm)
Ø 50



Peso netto
Net weight (kg)
66,0 kg



Dimensioni prodotto
Product dimension (mm)
B. 640 / D. 780 / H. 1220

Dimensione imballo
Packing dimensions (mm)
B. 700 / D. 800 / H. 1300



30 CON PIEDI KG 0,90 Kw (1,2 Hp)

codice prodotto product code

30 KG SUPPORTO STANDARD 0,90 Kw (1,2 Hp)

codice prodotto product code

30 KG SUPPORTO ALTO 0,90 Kw (1,2 Hp)

codice prodotto product code

CF cassetto e filtro optional for drawer-filter

NORME CE / CE APPROVED

Trifase / Three phase V. 230/400

Monofase / Single phase V. 230

SENZA NORME CE / NON CE APPROVED

Trifase / Three phase V. 230/400

Monofase / Single phase V. 230

FP116P

FP114P

FP116PE

FP114PE

FP116

FP114

FP116E

FP114E

FP117

FP115

FP117E

FP115E

di serie / included

La versione non CE di base non prevede cassetto e filtro

Non Ce approved model is not inclusive of waste filter drawer

COMPONENTI E ACCESSORI PELAPATATE

POTATO PEELER COMPONENTS AND ACCESSORIES

COPERCHIO TRASPARENTE

5-10-18 KG

5-10-18 KG

TRANSPARENT LID

Di serie / Included



COPERCHIO IN ACCIAIO

INOX 5-10-18 KG

5-10-18 KG STAINLESS

STEEL LID

Optional



COPERCHIO IN ACCIAIO

INOX 30 KG

30 KG STAINLESS STEEL LID

Di serie / Included



PARETE ABRASIVA SU TUTTI
I MODELLI FACILMENTE
SMONTABILE PER UNA CORRETTA
PULIZIA SENZA L'UTILIZZO
DI UTENSILI

*EASY ACCESSORY CHANGING
CLUTCH AND DISASSEMBLY
FOR CLEANING ON
ALL MODELS*



PIATTO PELAPATATE

5-10-18 KG

5-10-18 KG POTATO PEE-

LER PLATE

Di serie / Included



TELA ABRASIVA

5-10-18 KG

5-10-18 KG ABRASIVE WALL

Di serie / Included



PIATTO PELAPATATE

30 KG

30 KG POTATO PEELER

PLATE

Di serie / Included



TELA ABRASIVA

30 KG

30 KG ABRASIVE WALL

Di serie / Included

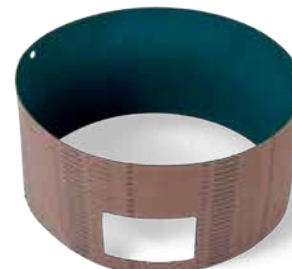

ALTEZZA SUPPORTO ALTO 460 MM

ALTEZZA SUPPORTO

STANDARD 210 MM

*Higher support 460 mm
Standard support 210 mm*







PULISCICOZZE SERIE 5 kg 5 kg MUSSEL WASHER

- Macchinario per uso professionale • Struttura completamente in acciaio inossidabile AISI 304 • Motore asincrono ventilato di produzione nazionale • Pareti abrasive facilmente sostituibili senza l'utilizzo di attrezzi • Elettrovalvola elettronica per ingresso acqua • Micro al coperchio e sportello • Coperchio in plastica trasparente infrangibile • Coperchio in acciaio inox (a richiesta) • Cassetto filtro allo scarico di serie • Visibili e pratici comandi digitali • Apparato elettrico esterno protetto da scatola di plastica isolata • Timer digitale multifunzione • Pulsante manuale per scarico prodotto • Collettore di scarico a terra o parete • Trasmissione a cinghia • Esclusivo piatto per lavorazione cozze brevettato • Norme CE • Fabbricato in Italia

- Professional equipment • Entirely structured in AISI 304 s/steel • Ventilated asynchronous Italian make motor • Abrasives designed to enable the user to operate, clean and maintain with the minimum of effort • Water jets electronic valve • Safety micro switch assembled on the cover and chute • Unbreakable transparent plastic cover • Waste filter drawer included • Digital and user-friendly control panel • Electric parts covered by safety ergonomic plastic case • Multifunction digital timer • Manual discharge button • Wall or floor discharge outlet • Belt transmission • Licensed mussel washer plate • CE approved • Proudly Made in Italy



Alimentazione
Power supply (Volt/Hz)

Potenza
Motor power (Kwatt/
Hp)

Giri piatto
Peeler dish
revolutions (RPM)

Produzione oraria
Production per hour
(kg/h)

Tempo ciclo
pulitura
Peeling cycle (sec)

Carico massimo
Maximum charge (kg)

Temperatura acqua
Water
temperature (°C)

Alimentazione tubo
flessibile
Flexible pipe feeding
(inch)

Collettore scarico
laterale
Side discharge
manifold (mm)

5 KG

230/50 230-400/50

0,35 (0,50)

145

75

90-120

5

5-20

3/4

ø50

DA BANCO

BENCHTOP MODEL



Collettore scarico inferiore
Lower discharge manifold (mm)



Peso netto
Net weight (kg)
25,0 kg



Dimensioni prodotto
Product dimension (mm)
B. 530 / D. 520 / H. 520



SUPPORTO STANDARD

CON CASSETTO E FILTRO INCLUSO
INCLUSIVE OF WASTE FILTER DRAWER



Collettore scarico inferiore
Lower discharge manifold (mm)
Ø40



Peso netto
Net weight (kg)
32,0 kg



Dimensioni prodotto
Product dimension (mm)
B. 530 / D. 520 / H. 700



SUPPORTO ALTO

CON CASSETTO E FILTRO INCLUSO
WITH HIGH STAND INCLUSIVE OF WASTE FILTER DRAWER



Collettore scarico inferiore
Lower discharge manifold (mm)
Ø 50



Peso netto
Net weight (kg)
35,0 kg



Dimensioni prodotto
Product dimension (mm)
B. 530 / D. 520 / H. 950



	NORME CE / CE APPROVED		SENZA NORME CE / NON CE APPROVED	
	Trifase / Three phase V. 230/400	Monofase / Single phase V. 230	Trifase / Three phase V. 230/400	Monofase / Single phase V. 230
5 KG BANCO 0,35 Kw (0,50 Hp) <i>codice prodotto product code</i>	FPC301	FPC300	FPC301E	FPC300E
5 KG SUPPORTO STANDARD 0,35 Kw (0,50 Hp) <i>codice prodotto product code</i>	FPC303	FPC302	FPC303E	FPC302E
5 KG SUPPORTO ALTO 0,35 Kw (0,50 Hp) <i>codice prodotto product code</i>	FPC305	FPC304	FPC305E	FPC304E
CI supplemento per coperchio inox <i>optional for stainless steel lid</i>	su richiesta / on request		su richiesta / on request	
CF cassetto e filtro <i>optional for drawer-filter</i>	di serie / included		La versione non CE di base non prevede cassetto e filtro	Non Ce approved model is not inclusive of waste filter drawer

• I macchinari senza norme CE sono destinati ai paesi fuori dalla Comunità Europea / Not suitable for EC countries • Le illustrazioni sono riferite ai modelli CE / Pictures refer to CE approved models



PULISCICOZZE SERIE 10-18 kg

10-18 kg MUSSEL WASHER



- Macchinario per uso professionale • Struttura completamente in acciaio inossidabile AISI 304 • Motore asincrono ventilato di produzione nazionale • Pareti abrasive facilmente sostituibili senza l'utilizzo di attrezzi • Elettrovalvola elettronica per ingresso acqua • Micro al coperchio e sportello • Coperchio in plastica trasparente infrangibile • Coperchio in acciaio inox (a richiesta) • Cassetto filtro allo scarico di serie • Visibili e pratici comandi digitali • Apparato elettrico esterno protetto da scatola di plastica isolata • Timer digitale multifunzione • Pulsante manuale per scarico prodotto • Collettore di scarico a terra o parete • Trasmissione a cinghia • Esclusivo piatto per lavorazione cozze brevettato • Norme CE • Fabbricato in Italia

- Professional equipment • Entirely structured in AISI 304 s/steel • Ventilated asynchronous Italian make motor • Abrasives designed to enable the user to operate, clean and maintain with the minimum of effort • Water jets electronic valve • Safety micro switch assembled on the cover and chute • Unbreakable transparent plastic cover • Waste filter drawer included • Digital and user-friendly control panel • Electric parts covered by safety ergonomic plastic case • Multifunction digital timer • Manual discharge button • Wall or floor discharge outlet • Belt transmission • Licensed mussel washer plate • CE approved • Proudly Made in Italy

	Alimentazione Power supply (Volt/Hz)	Potenza Motor power (Kwatt/ Hp)	Giri piatto Peeler dish revolutions (RPM)	Produzione oraria Production per hour (kg/h)	Tempo ciclo pulitura Peeling cycle (sec)	Carico massimo Maximum charge (kg)	Temperatura acqua Water temperature (°C)	Alimentazione tubo flessibile Flexible pipe feeding (inch)	Collettore scarico laterale Side discharge manifold (mm)
10 KG	230/50 230-400/50	0,35 (0,50)	180	150	120-150	10	5-20	3/4	ø50
18 KG	230/50 230-400/50	0,90 (1,20)	180	250	150-180	18	5-20	3/4	ø50

10 KG SUPPORTO STANDARD CON CASSETTO E FILTRO INCLUSO

INCLUSIVE OF WASTE FILTER DRAWER



Collettore scarico inferiore
Lower discharge manifold (mm)
Ø 40



Peso netto
Net weight (kg)
37,0 kg



Dimensioni prodotto
Product dimension (mm)
B. 530 / D. 660 / H. 850



10 KG SUPPORTO ALTO CON CASSETTO E FILTRO INCLUSO

WITH HIGH STAND INCLUSIVE OF WASTE FILTER DRAWER



Collettore scarico inferiore
Lower discharge manifold (mm)
Ø 50



Peso netto
Net weight (kg)
40,0 kg



Dimensioni prodotto
Product dimension (mm)
B. 530 / D. 660 / H. 1100



18 KG SUPPORTO STANDARD CON CASSETTO E FILTRO INCLUSO

INCLUSIVE OF WASTE FILTER DRAWER



Collettore scarico inferiore
Lower discharge manifold (mm)
Ø 40



Peso netto
Net weight (kg)
42,0 kg



Dimensioni prodotto
Product dimension (mm)
B. 530 / D. 660 / H. 950



Collettore scarico inferiore
Lower discharge manifold (mm)
Ø 50



Peso netto
Net weight (kg)
45,5 kg



Dimensioni prodotto
Product dimension (mm)
B. 530 / D. 660 / H. 1200



	NORME CE / CE APPROVED		SENZA NORME CE / NON CE APPROVED	
	Trifase / Three phase V. 230/400	Monofase / Single phase V. 230	Trifase / Three phase V. 230/400	Monofase / Single phase V. 230
10 KG SUPPORTO STANDARD 0,35 Kw (0,50 Hp) codice prodotto product code	FPC107	FPC106	FPC107E	FPC106E
10 KG SUPPORTO ALTO 0,35 Kw (0,50 Hp) codice prodotto product code	FPC307	FPC306	FPC307E	FPC306E
18 KG SUPPORTO STANDARD 0,65 Kw (0,90 Hp) codice prodotto product code	FPC109	FPC108	FPC109E	FPC108E
18 KG SUPPORTO ALTO 0,65 Kw (0,90 Hp) codice prodotto product code	FPC309	FPC308	FPC309E	FPC308E
CI supplemento per coperchio inox optional for stainless steel lid	su richiesta / on request		su richiesta / on request	
CF cassetto e filtro optional for drawer-filter	di serie / included		La versione non CE di base non prevede cassetto e filtro	Non Ce approved model is not inclusive of waste filter drawer

• I macchinari senza norme CE sono destinati ai paesi fuori dalla Comunità Europea / Not suitable for EC countries • Le illustrazioni sono riferite ai modelli CE / Pictures refer to CE approved models

COMPONENTI E ACCESSORI PULISCICOZZE

MUSSEL WASHER ACCESSORIES



PIATTO PULISCICOZZE 5 KG
5 KG MUSSEL WASHER PLATES

Di serie / Included



PIATTO PULISCICOZZE 10/18 KG
10/18 KG MUSSEL WASHER PLATES

Di serie / Included



TELA ABRASIVA
ABRASIVE WALL

Di serie / Included



PARETE ABRASIVA SU TUTTI I MODELLI
FACILMENTE SMONTABILE PER UNA CORRETTA
PULIZIA SENZA L'UTILIZZO DI UTENSILI

EASY ACCESSORY CHANGING CLUTCH AND
DISASSEMBLY FOR CLEANING ON ALL MODELS



COPERCHIO IN ACCIAIO INOX
STAINLESS STEEL LID

Optional



ALTEZZA SUPPORTO STANDARD 210 MM
ALTEZZA SUPPORTO ALTO 460 MM

STANDARD SUPPORT 210 MM
HIGHER SUPPORT 460 MM





LAVATARTUFO TRUFFLE WASHER



- Apparecchio per uso professionale • Struttura completamente in acciaio inossidabile AISI 304 • Motore asincrono ventilato di produzione nazionale • Elettrovalvola elettronica per ingresso acqua • Micro di sicurezza al coperchio e allo sportello di scarico • Coperchio in plastica trasparente infrangibile di serie su modello 10/18 kg Base • Coperchio in acciaio inox nei modelli IDRO e IDRO VV di serie • Coperchio in acciaio inox su modello 10/18 kg Base optional • I modelli IDRO e IDRO VV sono dotati di pompa idraulica da 8 Bar • Il modello IDRO VV è dotato di controllo continuo della velocità di rotazione tramite scheda inverter integrata da 50 a 300 giri/minuto • Doppio ugello con spruzzo a ventaglio • Piatto con setole (Optional) • Cassetto scorie e filtro di serie • Visibili e pratici comandi digitali • Apparato elettrico esterno protetto da ergonomica scatola di plastica isolata • Timer digitale multifunzione • Pulsante manuale per scarico prodotto • Scheda elettronica protetta con scatola in plastica IP 55 • Collettore di scarico a terra o parete • Trasmissione a cinghia • Norme CE • Fabbricato in Italia

- Professional equipment • AISI 304 s/steel construction • Premium made in Italy asynchronous ventilated motor • Electronic electrovalve water inlet • Lid and door safety microswitch • Robust see-through plastic lid on model 10/18 kg Base included • S/steel lid included for models IDRO/IDROVV • S/steel lid for model 10/18 kg Base optional • 8 bar hydraulic pump on models IDRO/IDROVV • IDRO VV model comes with INVERTER speed rotation control board ranging from 50 to 300 RPM. • Double nozzle with fanlike water spray • Optional brush plate • Supplied with waste filter drawer • Digital user-friendly control panel • Plastic box housed electrical system • Multifunctions digital timer • Manual discharge button • IP55 plastic box control board protection • Floor or side waste collector • Belt driven • CE approved • Proudly Made in Italy

Le versioni base necessitano per un ottimale lavaggio del tartufo una pressione di acqua di rete da 8-10 bar
"BASE" models must be operated with water pressure not lower than 8-10 bar for proper truffle cleaning

Alimentazione Power supply (Volt/Hz)	Potenza Motor power (Kwatt/Hp)	Giri piatto Peeler dish revolutions (RPM)	Produzione oraria Production per hour (kg/h)	Tempo ciclo pulitura Peeling cycle (sec)	Carico massimo Maximum charge (kg)	Temperatura acqua Water temperature (°C)	Alimentazione tubo flessibile Flexible pipe feeding (inch)	Collettore scarico laterale Side discharge manifold (mm)
--	--------------------------------------	---	--	--	--	---	---	---

18 KG IDRO	230/50	1,10 (1,50)	180	250	120-150	5-20	3/4	ø50
18 KG IDRO VV			65-220					
30 KG IDRO VV			350	30				

18 KG



Collettore scarico inferiore
Lower discharge manifold (mm)
Ø 50



Peso netto
Net weight (kg)
48,0 / 56,0 / 57,0 kg



Dimensioni prodotto
Product dimension (mm)
B. 530 / D. 660 / H. 1200



30 KG



Collettore scarico inferiore
Lower discharge manifold (mm)
Ø 50



Peso netto
Net weight (kg)
72 kg



Dimensioni prodotto
Product dimension (mm)
B. 640 / D. 780/850 / H. 1460



NORME CE / CE APPROVED

Trifase / Three phase V. 230/400

Monofase / Single phase V. 230

LAVARTUFO 18 KG IDRO 0,65 Kw (0,90 Hp)

codice prodotto product code

FLTI112

LAVARTUFO 18 KG IDRO VV 1,10 Kw (1,50 Hp)

codice prodotto product code

FLTI112VV

LAVARTUFO 30 KG IDRO VV 1,10 Kw (1,50 Hp)

codice prodotto product code

FLTI114VV

COMPONENTI E ACCESSORI LAVATARTUFO

TRUFFLE WASHER ACCESSORIES



PIATTO LAVATARTUFI
TRUFFLE WASHER PLATE

Di serie / Included



UGELLI PER LAVAGGIO TARTUFI
TRUFFLE WASH NOZZLES

Di serie / Included



MODELLO IDRO VV
CON VARIATORE DI VELOCITÀ

IDRO VV MODEL
WITH SPEED VARIATOR



CASSETTO E FILTRO
DRAWER AND FILTER

Di serie / Included



COPERCHIO INOX
STAINLESS STEEL LID

Di serie / Included



PIATTO SPAZZOLA LAVATARTUFI
(0,3 E 0,5 MM)

Optional solo per 18kg

TRUFFLE WASHER BRUSH PLATE
(0,3 AND 0,5 MM)

For model 18kg only



KIT RUOTE
WHEELS KIT

Optional

NORME CE / CE APPROVED

Piatto setole extra morbide 0,3 mm
Plate with extra soft bristles 0.3 mm

F3312

Piatto setole morbide 0,5 mm
Plate with soft bristles 0.5 mm

F3323

Kit N.4 ruote
Kit n.4 wheels

F3322





TAGLIAVERDURE VEGETABLE SHREDDER

- Macchinario per uso professionale • Vasta scelta di dischi dal più semplice al più creativo • Cambio dischi semplice e rapido • Carena in acciaio inox 304 • Coperchio in acciaio inox e vaschetta di taglio facilmente rimovibili per una più semplice e accurata pulizia • Bocca di scarico inclinata per una maggior produttività • Maniglia ergonomica con funzione start/stop e bloccaggio in posizione di carico • Tutte le parti a contatto con gli alimenti sono in acciaio inox o plastica alimentare • Tastiera digitale con indicazioni luminose a led • Comando ad impulsi per una maggiore precisione di taglio • Motore potente e ventilato adatto ad un uso intensivo • Trasmissione a cinghia • Microinterruttore di protezione • Chiusura al basamento • Pestello in ABS • Facile da smontare e pulire • Dispositivi di sicurezza a norma CE per la massima protezione dell'operatore • Fabricato in Italia

- Professional heavy duty equipment • Full range of cutting, slicing and grating discs available • Fast blade change • AISI 304 S/steel casing • Frame and lid made from stainless steel • Cutting bowl designed for easy cleaning • Ergonomic handle equipped with on/o safety interlocking switch • All cutting parts made from stainless steel or food suitable plastic • S/steel lid easy removable for cleaning • Led lights digital keyboard • Pulse controls for precise cut • Heavy duty asynchronous ventilated motor • Belt transmission • Safety micro switch • All moving parts fully interlocked giving additional safety to the user • ABS pestle • Easy clean up • CE approved • Proudly Made in Italy



Produzione oraria 250-450 kg/h
Production per hour 250-450 kg/h

Produzione oraria 450-600 kg/h
Production per hour 450-600 kg/h

	Alimentazione Power supply (Volt/Hz)	Potenza Motor power (Kwatt/Hp)	Produzione oraria Production per hour (kg/h)
ÉLITE	230/50	0,58 (0,80)	250-450
ÉLITE PRO	230-400/50		450-600

ÉLITE

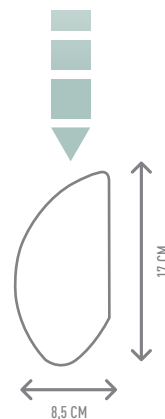

INGRESSO CAPACITÀ STANDARD
STANDARD CAPACITY INLET

ÉLITE PRO

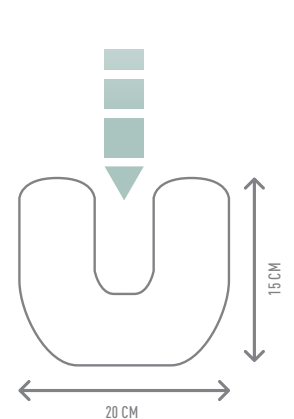

INGRESSO AD ALTA CAPACITÀ
HIGH CAPACITY INLET

ÉLITE



Collettore scarico inferiore
Lower discharge manifold (mm)
Ø 40



Peso netto
Net weight (kg)
20,0 kg



Dimensioni prodotto
Product dimension (mm)
B. 300 / D. 500 / H. 540



Ingresso capacità standard
Standard capacity inlet

ÉLITE PRO



Collettore scarico inferiore
Lower discharge manifold (mm)
Ø 40



Peso netto
Net weight (kg)
20,0 kg



Dimensioni prodotto
Product dimension (mm)
B. 300 / D. 500 / H. 540



Ingresso ad alta capacità
High capacity inlet



	NORME CE / CE APPROVED		SENZA NORME CE / NON CE APPROVED	
	Trifase / Three phase V. 230/400	Monofase / Single phase V. 230		Monofase / Single phase V. 230
TAGLIAVERDURE ÉLITE 0,58 Kw (0,80 Hp) codice prodotto <i>product code</i> Senza dischi + disco espulsore Without discs + ejectable disc	FTV401	FTV400		FTV400E
TAGLIAVERDURE ÉLITE 0,58 Kw (0,80 Hp) codice prodotto <i>product code</i> Con dischi: E2 - E10 - D10X10 - B10 - Z3 - Z7 + disco espulsore With discs: E2 - E10 - D10X10 - B10 - Z3 - Z7 + ejectable disc	FTV301	FTV300		FTV300E
TAGLIAVERDURE ÉLITE PRO 0,58 Kw (0,80 Hp) codice prodotto <i>product code</i> Senza dischi + disco espulsore Without discs + ejectable disc	FTV701	FTV700		FTV700E
TAGLIAVERDURE ÉLITE PRO 0,58 Kw (0,80 Hp) codice prodotto <i>product code</i> Con dischi: E2 - E10 - DP10X10 - BP10 - Z3 - Z7 + disco espulsore With discs: E2 - E10 - DP10X10 - BP10 - Z3 - Z7 + ejectable disc	FTV601	FTV600		FTV600E

INTERAMENTE SMONTABILE PER MIGLIORE PULIZIA

EASE OF CLEANING WITH MANUALLY
REMOVABLE PARTS

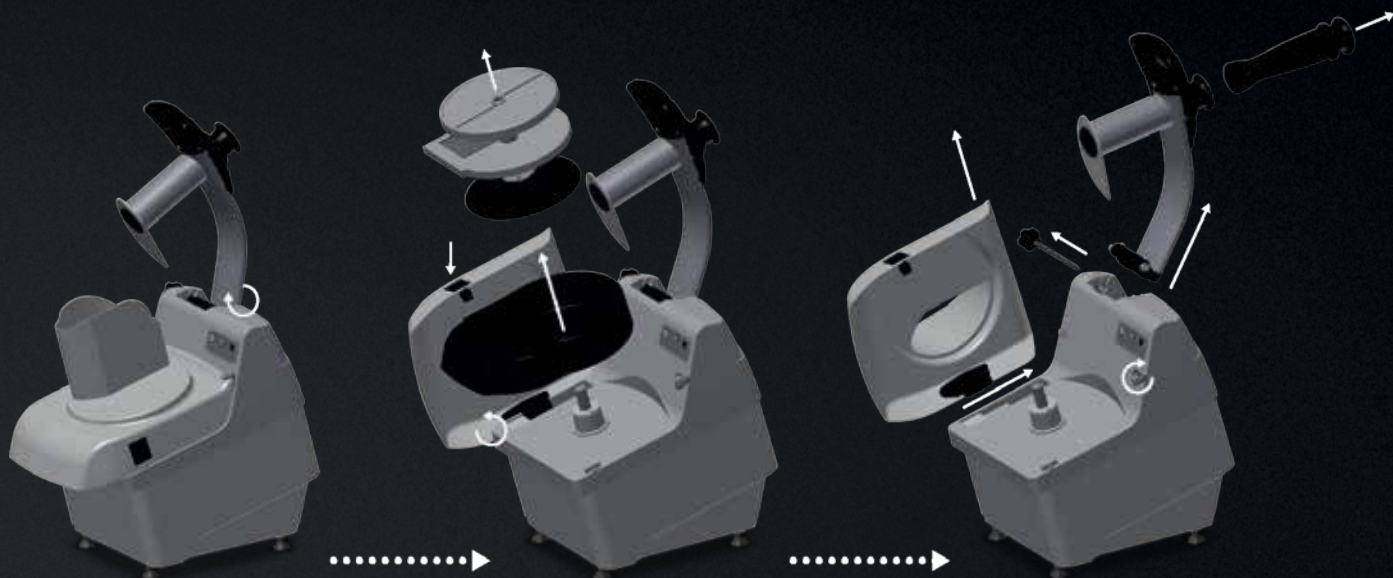

DIMENSIONI TAGLIAVERDURE ÈLITE DIMENSION ÈLITE VEGETABLE SHREDDER

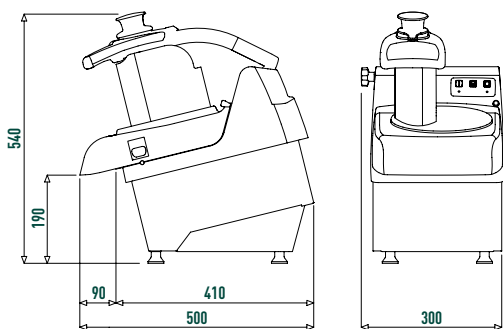

DIMENSIONI TAGLIAVERDURE ÈLITE PRO DIMENSION ÈLITE PRO VEGETABLE SHREDDER

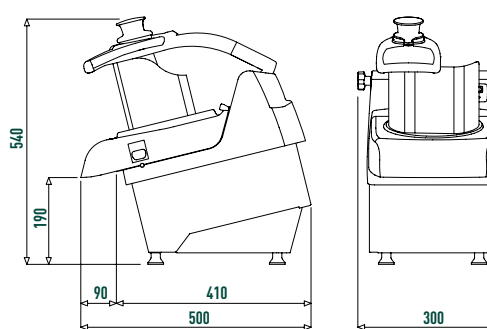

DISCHI TAGLIAVERDURE VEGETABLE SHREDDER DISCS

Tutti i dischi sono compatibili con entrambe le versioni **ÈLITE** ed **ÈLITE PRO**,

ad esclusione delle serie "**B Pro**" e "**D Pro**", adatte solo al tagliaverdure **ÈLITE PRO**

All discs are compatible with both ÈLITE and ÈLITE PRO versions, with the exception of the "B Pro" and "D Pro" series, suitable only for the ÈLITE PRO vegetable shredder

PORTADISCHI 8 PEZZI
DISK RACK 8 PIECES



X

CODICE

FTV191

SERIE X / X SERIES

dischi per taglio fette regolabili 1x8 da 1 a 8 mm adjustable slicing disc variable from 1-8 mm

ARTICOLO

X

CODICE

FTV174



E8 E10 E14

E1 E2 E3 E4 E5 E6

SERIE E / E SERIES

dischi per taglio fette delicate *slicing discs*

ARTICOLO	CODICE	ARTICOLO	CODICE
E1	FTV175	E2	FTV176
E3	FTV177	E4	FTV178
E5	FTV179	E6	FTV180
E8	FTV115	E10	FTV116
E14	FTV117		

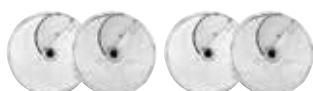

S1 S2 S4 S10

SERIE S / S SERIES

dischi per taglio fette delicate *slicing discs*

ARTICOLO	CODICE	ARTICOLO	CODICE
S1	FTV181	S2	FTV182
S4	FTV203	S10	FTV204

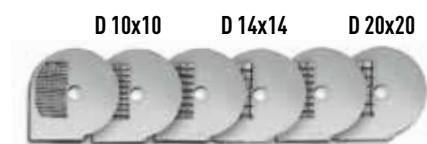

D 8x8 D 12x12 D 16x16

SERIE D / D SERIES

dischi per cubettare (vanno sempre abbinati alla serie E) *cube cutting discs to be purchased with E disk*

ARTICOLO	CODICE	ARTICOLO	CODICE
D 8x8	FTV183	D 10x10	FTV184
D 12x12	FTV185	D 14x14	FTV202
D 16x16	FTV194	D 20x20	FTV186



DP 8x8 DP 10x10 DP 14x14



SERIE D PRO - SOLO PER ÈLITE PRO / D PRO SERIES - ONLY FOR ÈLITE PRO

dischi per cubettare (vanno sempre abbinati alla serie E) *cube cutting discs to be purchased with E disk*

ARTICOLO	CODICE	ARTICOLO	CODICE
DP 8x8	FTV206	DP 10x10	FTV207
DP 14x14	FTV208		



B6 B8 B10

SERIE B / B SERIES

dischi per taglio listelli (vanno sempre abbinati alla serie E) *chipper discs to be purchased with E disk*

ARTICOLO	CODICE	ARTICOLO	CODICE
B6	FTV130	B8	FTV131
B10	FTV132		

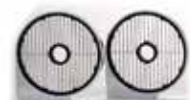

BP 8 BP 10



SERIE B PRO - SOLO PER ÈLITE PRO / B PRO SERIES - ONLY FOR ÈLITE PRO

dischi per taglio listelli (vanno sempre abbinati alla serie E) *chipper discs to be purchased with E disk*

ARTICOLO	CODICE	ARTICOLO	CODICE
BP8	FTV209	BP10	FTV210



H4 H6 H8 H10

SERIE H / H SERIES

dischi per taglio listelli ricurvi *staw cutting discs*

ARTICOLO	CODICE	ARTICOLO	CODICE
H4	FTV187	H6	FTV188
H8	FTV189	H10	FTV190



Z2 Z3 Z4 Z7 Z10

SERIE Z / Z SERIES

dischi per sfilacciare *shredding discs*

ARTICOLO	CODICE	ARTICOLO	CODICE
Z2	FTV118	Z3	FTV119
Z4	FTV120	Z7	FTV121
Z10	FTV199		



V

SERIE V / V SERIES

dischi per grattugiare pane e formaggio *grating discs suitable for cheese and bread*

ARTICOLO	CODICE
V	FTV122

TAGLIAVERDURE

VEGETABLE CUTTER



• Macchinario per uso professionale • Struttura in fusione di alluminio e lega di magnesio • Coperchio in alluminio smontabile per pulizia • Motore ventilato • Trasmissione a cinghia • Comandi start/stop con scheda elettronica in bassa tensione • Microinterruttore di protezione su coperchio e leva pressamerce • Inclusi 5 dischi per taglio (due dischi per affettare da 2 e 4mm di spessore e tre dischi per sfilacciare, da 3, 4 e 7mm di spessore) • Pestello in ABS • Norme CE

• Professional equipment • Structure in cast aluminium and magnesium alloy • Completely removable aluminium cover for easy cleaning • Ventilated motor • Belt transmission • Start/stop switches with low voltage electronic board • Safety switches on both cover and lever • 5 cutting discs included (two for slicing, 2 and 4mm thickness; three for grating/julienne: 3, 4 and 7mm thickness) • ABS pestle • CE approved

TAGLIAVERDURE TV25K

Dimensioni prodotto
Product dimension (mm)
B. 230 mm / D. 570 mm / H. 510 mm



DISCHI OPZIONALI
AVAILABLE PLATES



Alimentazione Power supply (Volt/Hz)	Assorbimento Power input (Kwatt)	Velocità Speed (RPM)	Produzione oraria Production per hour (kg/h)	Peso netto Net weight (kg)
230 / 50	0,55	270	200	22,5

TV 25K

NORME CE / CE APPROVED

Monofase / Single phase V. 230

FTV500

SENZA NORME CE / NON CE APPROVED

Monofase / Single phase V. 230

FTV500E

TV25K 0,55 Kw
codice prodotto product code







CUTTER CON VARIAZIONE DI VELOCITÀ

BOWL CUTTER

• Macchinario per uso professionale • Robusta struttura in acciaio inox AISI 430 • Motore e vasca affiancati che permettono di isolare dal calore il prodotto lavorato • Vasche in acciaio inox con fondo termico e manici • Motori ventilati ad alto rendimento per uso continuo • Robusti coltelli a lame curve in acciaio temprato da coltelleria • Sicurezza garantita da un sistema a doppio microinterruttore sul coperchio • Coperchio in Lexan trasparente che permette ottima visibilità durante la lavorazione • Foro di aggiunta ingredienti su coperchio • Variatore di velocità stabilizzato con controllo di potenza • Modelli L4VV-6-9 disponibili con variatore continuo di velocità (di serie su L9VV) • In dotazione: spatola e piastra affilatura lame • Opzionali mozzi con lame: dentate, forate, per pesto, per impasti • Norme CE • Fabbriato in Italia

• Professional equipment • Strong AISI 430 steel construction • Detached motor and bowl for a better thermal insulation • S/S bowl with handles and heavy bottom • High efficiency ventilated motor for continuous operation • Strong cutlery steel knives • Safe operations ensured by a system of micro switches on the lid • See-through lexan lid • Lid with opening to add ingredients during operation • Speed control with stabilizer • L4, L6 and L9 available with steplessly variable-speed drive • Standard: spatula and sharpening stones • Optional: serrated knives, emulsifying knives, knives for pesto sauce and knives to mix dough • CE approved • Proudly Made in Italy



	Alimentazione Power supply (Volt/Hz)	Potenza Motor power (Kwatt/Hp)	Giri motore Motor revolutions (g/m)	Volume vasca Tank diameter (lt)	Capienza utile vasca Bowl filling capacity (lt)
4 LITRI	230/50	0,35 (0,50)	1500/2800	3,3	1,5
6 LITRI				5,3	3,1
9 LITRI		0,35 (0,50) x2		9,4	5,4

4 LITRI

4 LITERS



Peso netto
Net weight (kg)
10,0 kg



Dimensioni prodotto
Product dimension (mm)
B. 365 / D. 305 / H. 255



6 LITRI

6 LITERS



Peso netto
Net weight (kg)
11,0 kg



Dimensioni prodotto
Product dimension (mm)
B. 365 / D. 305 / H. 320



9 LITRI

9 LITERS



Peso netto
Net weight (kg)
23,0 kg



Dimensioni prodotto
Product dimension (mm)
B. 455 / D. 225 / H. 380



NORME CE / CE APPROVED

Monofase / Single phase V. 230

L4V 0,35 Kw (0,50 Hp)

codice prodotto product code

FL4V

L6V 0,35 Kw (0,50 Hp)

codice prodotto product code

FL6V

L9V 0,35 + 0,35 Kw (0,50 + 0,50 Hp)

codice prodotto product code

FL9V



CUTTER BOWL CUTTER

- Macchinario per uso professionale • Corpo macchina realizzato in acciaio inox 304 • Vasca estraibile • Motore asincrono ventilato • Freno motore • Termica di protezione • Micro al coperchio • Comandi digitali a 24 volt • Coltelli in acciaio inox • Coperchio in plastica trasparente • Norme CE • Fabbricato in Italia

- Professional equipment • Casing entirely made from AISI 304 s/steel • Removable tank • Asynchronous ventilated motor • Motor brake • Thermal overload protection included • Safety micro switch on the lid • 24 volt digital controls • S/steel blades • Transparent lid • CE approved • Proudly Made in Italy

3 LITRI
3 LITERS



Peso netto
Net weight (kg)
13,5 kg



Dimensioni prodotto
Product dimension (mm)
B. 200 / D. 230 / H. 410



Alimentazione
Power supply
(Volt/Hz)

Potenza
Motor power
(Kwatt/Hp)

Giri motore
Motor revolutions
(g/m)

Volume vasca
Tank diameter (lt)

Capienza utile
vasca
Bowl filling capacity
(lt)

3 LITRI	230/50 230-400/50	0,55 (0,75)	1400	3	1,45
----------------	----------------------	-------------	------	---	------

NORME CE / CE APPROVED

Trifase / Three phase V. 230/400

Monofase / Single phase V. 230

FCU102

FCU100

L3 cutter 3 litri cutter 3 ltr
codice prodotto product code

MOTORE A DUE VELOCITÀ SOLO TRIFASE DOUBLE SPEED OPTION IS AVAILABLE FOR THREE-PHASE MODELS ONLY

IN DOTAZIONE, MOZZO CON LAME TAGLIENTI SUPPLIED WITH PLAIN CUTTING ASSEMBLY

LAME PER CUTTER

CUTTING BLADE FOR CUTTER



Passato di pomodoro
Tomato sauce



Pane grattugiato
Breadcrumbs



Mozzarella pizza
Mozzarella grating



Passato verdure
Vegetables purée

LAMA TAGLIENTE

CUTTING BLADE



Carne per ragù
Meat mincing



Frutta secca
Dried fruit-nuts

LAMA SEGHETTATA

SAW - TOOTHED BLADE



Maionese
Mayonnaise



Cioccolato
Chocolate



Impasti teneri per dolci
Soft mixtures

LAMA FORATA

PUNCHED BLADE

RICAMBI PER CUTTER

ACCESSORIES FOR CUTTER

Mozzi completi (taglienti, dentate o forate) per L3 L3 cutting blade assembly (please mention plain, serrated or perforated)

FCU 112

Coperchio in plastica per L3 L3 cutter plastic lid

FCU 114M



TAGLIAMOZZARELLA

MOZZARELLA CHEESE CUTTER

- Macchinario per uso professionale • Robusta struttura in lamiera di acciaio inox 304 • Riduttore ingranaggi elicoidali a bagno d'olio • Robusto motore asincrono di produzione nazionale • Termica di protezione • Sportello allo scarico in ABS con micro di protezione • Cono taglia mozzarella in acciaio inox • Disponibili varie misure di coni • Tramoggia e piatto raccolta in acciaio inox • Pestello in ABS • Comandi a 24 volt • Norme CE • Fabbricato in Italia

- Professional equipment • Stiffened structure made from AISI 304 s/steel • Oil immersed gears reducer • Italian make heavy duty asynchronous motor • Thermal overload protection included • ABS discharging chute equippe with safety micro switch • Stainless steel cutting cones • Different cutting cones dimensions • S/steel hopper and tray • ABS pestle • 24 volt control panel ensures safety during operation, and gives the operator maximum security • CE approved • Proudly Made in Italy



Alimentazione
Power supply (Volt/Hz)

Potenza
Motor power
(Kwatt/Hp)

Giri motore
Motor revolutions
(g/m)

Produzione oraria
Production per hour
(kg/h)

TMC

230/50 - 230-400/50

0,75 (1,00)

1400

50

TMC



Peso netto
Net weight (kg)
18 kg



Dimensioni prodotto
Product dimension (mm)
B. 220 / D. 420 / H. 440



NORME CE / CE APPROVED		SENZA NORME CE / NON CE APPROVED	
Trifase / Three phase V. 230/400	Monofase / Single phase V. 230	Trifase / Three phase V. 230/400	Monofase / Single phase V. 230
FTMC100	FTMC102	FTMC100E	FTMC102E

TMC carenato inox *faired stainless steel*
codice prodotto *product code*

IL TAGLIAMOZZARELLA VIENE DOTATO DEL CONO DA 7 MM. SUPPLIED WITH STAINLESS STEEL 7 MM CONE

CONI INOX TAGLIAMOZZARELLA STAINLESS STEEL CONES



N.1

Lame spess. mm. 2 - Per affettare, ideale per funghi, zucchine ecc.

Hole 2 mm. - For slicing mushrooms, courgettes, etc.



N.2

Foro mm. 2,5 - Per sfilacciare formaggi teneri o poco stagionati

Hole 2.5 mm - For fraying tender soft or not too mature cheese



N.3

Foro mm. 4 - Per antipasti, realizza verdure a taglio Julienne

Hole 4 mm - For appetizers and, Julienne cut vegetables



N.4

Foro mm. 7 - Per sfilacciare mozzarella

Hole 7 mm - For fraying mozzarella cheese

N.1 codice prodotto <i>product code</i>	F2282
N.2 codice prodotto <i>product code</i>	F2280
N.3 codice prodotto <i>product code</i>	F2281
N.4 codice prodotto <i>product code</i>	F2182

• I macchinari senza norme CE sono destinati ai paesi fuori dalla Comunità Europea / *Not suitable for EC countries* • Le illustrazioni sono riferite ai modelli CE / *Pictures refer to CE approved models*



LAVORAZIONE CARNE
meat processing



PROFESSIONALITÀ ARTIGIANA
SU TUTTE LE LAVORAZIONI

CRAFTSMAN SKILL
IN FOOD PROCESSING

IMPASTACARNE
MEAT KNEADER

INSACCATRICI
SAUSAGE FILLERS

SEGAOSSA
BAND BONE SAW

SOTTOVUOTO A BARRA SALDANTE
SEALING BAR VACUUM MACHINE

SOTTOVUOTO CAMPANA
BELL SHAPED VACUUM MACHINE

TERMOSIGILLATRICI
THERMOSEALING MACHINES

PRESSHAMBURGER
BURGER PRESS





IMPASTACARNE MEAT KNEADERS

• Macchinario per uso professionale • Struttura in acciaio inox • Potente motore asincrono ventilato • Centralina a 24 volt • Ingranaggi elicoidali a bagno d'olio • Coperchio con micro di sicurezza • Vasca di lavorazione ribaltabile 90° • Pala di lavorazione in acciaio inox • Disponibili ruote con blocco • Norme CE • Fabbricato in Italia

• Professional equipment • Stainless steel bodywork • Powerful asynchronous ventilated motor • 24volt control panel ensures safety during operation, and gives the operator maximum security • Oil immersed gears • Safety micro switch on the lid • Folding mixing tank • Stainless steel mixing shovel • Wheels available • CE approved • Proudly Made in Italy



Alimentazione
Power supply (Volt/Hz)

Potenza
Motor power (Kwatt/Hp)

Capacità
Capacity (kg)

Peso netto mono/tri fase
Net weight single/three phase (kg)

Dimensione prodotto
Product dimensions (kg/h)

	Alimentazione Power supply (Volt/Hz)	Potenza Motor power (Kwatt/Hp)	Capacità Capacity (kg)	Peso netto mono/tri fase Net weight single/three phase (kg)	Dimensione prodotto Product dimensions (kg/h)
FIC 30M	230/50 - 230-400/50	0,75 (1,00)	30	40,0	B. 720 D. 360 H. 570
FIC 30MC				45,0	B. 720 D. 360 H. 1030
FIC 50M		1,50 (2,00)	50	80,0	B. 800 D. 460 H. 1020
FIC 50B		1,80 (2,40)		100,0	B. 800 D. 565 H. 1040
FIC 75M		1,50 (2,00)	75	85,0	B. 980 D. 460 H. 1020
FIC 100B		1,80 (2,40)	100	110,0	B. 1160 D. 565 H. 1040
FIC 120B			120	125,0	B. 1100 D. 630 H. 1080

FIC



	NORME CE / CE APPROVED
FIC 30M 30 kg monopala da banco 30 kg bench top single mixing arm codice prodotto product code	FIC30M
FIC 30MC 30 kg monopala completa di carrello 30 kg single mixing arm fitted on blocking wheels codice prodotto product code	FIC30MC
FIC 50M 50 kg monopala completa di carrello 50 kg single mixing arm fitted on blocking wheels codice prodotto product code	FIC50M
FIC 50B 50 kg bipala completa di carrello 50 kg double mixing arm fitted on blocking wheels codice prodotto product code	FIC50B
FIC 75M 75 kg monopala completa di carrello 75 kg single mixing arm fitted on blocking wheels codice prodotto product code	FIC75M
FIC 100B 100 kg bipala completa di carrello 100 kg double mixing arm fitted on blocking wheels codice prodotto product code	FIC100B
FIC 120B 120kg bipala completa di carrello 120 kg double mixing arm fitted on blocking wheels codice prodotto product code	FIC120B
VERSIONE MOTORE MONOFASE MAGGIORAZIONE SINGLE PHASE MOTOR SURCHARGE	
CARRELLO PER IMPASTACARNE: H. CARRELLO SENZA RUOTE 50CM H. CARRELLO COMPRESO DI RUOTE 95CM MEAT KNEADER TROLLEY: MEAT KNEADER TROLLEY HEIGHT 50 CM MEAT KNEADER TROLLEY HEIGHT INCLUSIVE OF WHEELS 95CM	FICC



INSACCATRICI SAUSAGE FILLERS

- Macchinario per uso professionale • Struttura in acciaio inossidabile • Cilindro in acciaio inox 18/8 – AISI 304 • Pistone in alluminio con speciale guarnizione • Due velocità • Maniglia lavorazione in alluminio • Set 3 imbusti differenti misure in abs • Ingranaggi in acciaio • Cremagliera in acciaio rettificato • Viteria in acciaio inox • Norme CE • Fabbriato in Italia

- Professional equipment • Stainless steel bodywork • 18/8 - AISI 304 stainless steel cylinder • Aluminium piston supplied with a special gasket • Double speed • Aluminium handle • 3 ABS funnels kit available in different sizes • Steel gears • Rectified steel rack • Stainless steel bolts and screws • CE approved • Proudly Made in Italy



Capacità
Capacity (lt.)

L7 V	7
L14 V	14
L7	7
L14	14

L7 V



Cilindro
Cylinder (mm)
Ø 156



Peso netto
Net weight (kg)
20 kg



Dimensioni prodotto
Product dimension (mm)
B. 300 / D. 460 / H. 740



L14 V



Cilindro
Cylinder (mm)
Ø 198



Peso netto
Net weight (kg)
27 kg



Dimensioni prodotto
Product dimension (mm)
B. 350 / D. 480 / H. 900



L7



Cilindro
Cylinder (mm)
Ø 156



Peso netto
Net weight (kg)
19,0 kg



Dimensioni prodotto
Product dimension (mm)
B. 230 / D. 800 / H. 240



L14



Cilindro
Cylinder (mm)
Ø 198



Peso netto
Net weight (kg)
27,0 kg



Dimensioni prodotto
Product dimension (mm)
B. 280 / D. 980 / H. 280



NORME CE / CE APPROVED

L 7

inox - 2 velocità orizzontale - 7 litri (6 kg)
Stainless steel - horizontal with double speed - 7 ltr (6 kg)
codice prodotto product code

FIN101

L 7 ECO

inox - 2 velocità orizzontale - 7 litri (6 kg)
Stainless steel - horizontal with double speed - 7 ltr (6 kg)
codice prodotto product code

FINI101

L 14

inox - 2 velocità orizzontale - 14 litri (13 kg)
Stainless steel - horizontal with double speed - 14 ltr (13 kg)
codice prodotto product code

FIN102

L 7 V

inox - 2 velocità verticale - 7 litri (6 kg)
Stainless steel - vertical with double speed - 7 ltr (6 kg)
codice prodotto product code

FIN103

L 14 V

inox - 2 velocità verticale - 14 litri (13 kg)
Stainless steel - vertical with double speed - 14 ltr (13 kg)
codice prodotto product code

FIN104

Serie 4 imbuti per insaccare 4 pcs. sausage filling kit

FINB



INSACCATRICI SAUSAGE FILLERS

- Macchinario per uso professionale
- Struttura portante in acciaio verniciato
- Cilindro in acciaio inox AISI 304
- Sistema brevettato per lo sfriato aria anteriore, senza l'utilizzo di valvole sul pistone
- Set 4 imbusti differenti misure in abs (15, 23, 28 e 38 mm)
- Ingranaggi in metallo per riduzione/moltiplicazione velocità (lenta per insaccare, veloce per estrarre il pistone)
- Due velocità (solo L5 e L8)
- Norme CE
- Fabbricato in Italia

- Professional equipment
- Painted steel support structure
- AISI 304 stainless steel cylinder
- 4 ABS funnels kit available in different sizes (15, 23, 28 e 38 mm)
- Metal gears
- Double speed (only L5 e L8)
- CE approved
- Proudly Made in Italy



Capacità
Capacity (lt.)

L3	3
L5	5
L8	8

L3 ECO



Cilindro
Cylinder (mm)
Ø 136



Peso netto
Net weight (kg)
7,5 kg



Dimensioni prodotto
Product dimension (mm)
B. 220 / D. 420 / H. 240



L5 ECO



Cilindro
Cylinder (mm)
Ø 136



Peso netto
Net weight (kg)
11,0 kg



Dimensioni prodotto
Product dimension (mm)
B. 255 / D. 590 / H. 250



L8 ECO



Cilindro
Cylinder (mm)
Ø 136



Peso netto
Net weight (kg)
13,0 kg



Dimensioni prodotto
Product dimension (mm)
B. 255 / D. 690 / H. 245



NORME CE / CE APPROVED

L 3
orizzontale - 3 litri
horizontal - 3 ltr
codice prodotto product code

FIN105

L 5
orizzontale - 5 litri
horizontal - 5 ltr
codice prodotto product code

FIN106

L 8
orizzontale - 8 litri
horizontal - 8 ltr
codice prodotto product code

FIN107

Serie 4 imbuti per insaccare 4 pcs. sausage filling kit

FINB



SEGAOSSA BONE BANDSAW



- Macchinario per uso professionale • Fusione di alluminio anodizzato o verniciato • Lama in acciaio di produzione nazionale • Ampio piano di lavoro in acciaio inossidabile • Spingi carne • Pulegge calibrate • Rapido sblocco puleggia superiore • Tendi lama registrabile • Porzionatore di taglio incorporato • Micro di protezione • Apparecchio certificato • Norme CE • Fabbricato in Italia

- Professional equipment • Fusion made from anodized or polished aluminium • Italian make steel blade • Wide stainless steel working surface • Meat pusher • Gauged pulley • Upper pulley easy unlock • Adjustable blade stretcher • Safety micro switch • Certified equipment • CE approved • Proudly Made in Italy

	Alimentazione Power supply (Volt/Hz)	Potenza Motor power (Kwatt/Hp)	Altezza massima di taglio Max cut height (mm)	Larghezza di taglio Cut width (mm)	Piano di lavoro Working table (mm)
1550 A	230/50 230-400/50	0,75 (1,00)	250	170	330x330
1550 V			210	175	380x380
1600 A		1,10 (1,50)			
1600 V			0,75 (1,00)	300	175
1650 A		320		200	410x410
1650 V					
1800 A					
1800 V					
1830 A					
1830 V					

1550 anodizzato *anodized*

<.....>

Lunghezza nastro
Cutting height (mm)
1550 mm



Peso netto
Net weight (kg)
34,0 kg



Dimensioni prodotto
Product dimension (mm)
B. 370 / D. 410 / H. 810



1550 verniciato *polished*

<.....>

Lunghezza nastro
Cutting height (mm)
1550 mm



Peso netto
Net weight (kg)
34,0 kg



Dimensioni prodotto
Product dimension (mm)
B. 370 / D. 410 / H. 810



1600 anodizzato *anodized*

<.....>

Lunghezza nastro
Cutting height (mm)
1610 mm



Peso netto
Net weight (kg)
35,5 kg



Dimensioni prodotto
Product dimension (mm)
B. 480 / D. 520 / H. 880



1600 verniciato *polished*

<.....>

Lunghezza nastro
Cutting height (mm)
1610 mm



Peso netto
Net weight (kg)
35,5 kg



Dimensioni prodotto
Product dimension (mm)
B. 480 / D. 520 / H. 880



1650 anodizzato *anodized*

<.....>

Lunghezza nastro
Cutting height (mm)
1650 mm



Peso netto
Net weight (kg)
33,0 kg



Dimensioni prodotto
Product dimension (mm)
B. 480 / D. 520 / H. 840



1650 verniciato *polished*

<.....>

Lunghezza nastro
Cutting height (mm)
1650 mm



Peso netto
Net weight (kg)
33,0 kg



Dimensioni prodotto
Product dimension (mm)
B. 480 / D. 520 / H. 840



1800 anodizzato anodized

<.....>

Lunghezza nastro
Cutting height (mm)
1800 mm



Peso netto
Net weight (kg)
38,0 kg



Dimensioni prodotto
Product dimension (mm)
B. 480 / D. 520 / H. 970



1800 verniciato polished

<.....>

Lunghezza nastro
Cutting height (mm)
1800 mm



Peso netto
Net weight (kg)
38,0 kg



Dimensioni prodotto
Product dimension (mm)
B. 480 / D. 520 / H. 970



1830 anodizzato anodized

<.....>

Lunghezza nastro
Cutting height (mm)
1830 mm



Peso netto
Net weight (kg)
38,0 kg



Dimensioni prodotto
Product dimension (mm)
B. 420 / D. 530 / H. 910



1830 verniciato polished

<.....>

Lunghezza nastro
Cutting height (mm)
1830 mm



Peso netto
Net weight (kg)
38,0 kg



Dimensioni prodotto
Product dimension (mm)
B. 420 / D. 530 / H. 910



	NORME CE / CE APPROVED		SENZA NORME CE / NON CE APPROVED	
	Trifase / Three phase V. 230/400	Monofase / Single phase V. 230	Trifase / Three phase V. 230/400	Monofase / Single phase V. 230
1550 verniciato - nastro 1550 mm <i>painted finish - 1550 mm bandsaw</i> codice prodotto <i>product code</i>	FSG100	FSGM100	FSG100E	FSGM100E
1550 anodizzato - nastro 1550 mm <i>anodized finish - 1550 mm bandsaw</i> codice prodotto <i>product code</i>	FSG101	FSGM101	FSG101E	FSGM101E
1600 verniciato - nastro 1600 mm <i>painted finish - 1600 mm bandsaw</i> codice prodotto <i>product code</i>	FSG106	FSGM106	FSG106E	FSGM106E
1600 anodizzato - nastro 1600 mm <i>anodized finish - 1600 mm bandsaw</i> codice prodotto <i>product code</i>	FSG107	FSGM107	FSG107E	FSGM107E
1650 verniciato - nastro 1650 mm <i>painted finish - 1650 mm bandsaw</i> codice prodotto <i>product code</i>	FSG112	FSGM112	FSG112E	FSGM112E
1650 anodizzato - nastro 1650 mm <i>anodized finish - 1650 mm bandsaw</i> codice prodotto <i>product code</i>	FSG113	FSGM113	FSG113E	FSGM113E
1800 verniciato - nastro 1800 mm <i>painted finish - 1800 mm bandsaw</i> codice prodotto <i>product code</i>	FSG108	FSGM108	FSG108E	FSGM108E
1800 anodizzato - nastro 1800 mm <i>anodized finish - 1800 mm bandsaw</i> codice prodotto <i>product code</i>	FSG109	FSGM109	FSG109E	FSGM109E
1830 verniciato - nastro 1830 mm <i>painted finish - 1830 mm bandsaw</i> codice prodotto <i>product code</i>	FSG102	FSGM102	FSG102E	FSGM102E
1830 anodizzato - nastro 1830 mm <i>anodized finish - 1830 mm bandsaw</i> codice prodotto <i>product code</i>	FSG103	FSGM103	FSG103E	FSGM103E
FSG CAV - optional cavallo per segaossa 75x50x35 cm - peso 8 kg <i>bonesaw support 75x50x35 cm - weight 8 kg</i>	su richiesta / <i>on request</i>		su richiesta / <i>on request</i>	
FSG CAS - optional cassetto raccogli segatura <i>drawer for sawing</i>	su richiesta / <i>on request</i>		su richiesta / <i>on request</i>	
Ricambio <i>accessories</i> anelli per segaossa mm. 1400-1750 confezione da 10 <i>1400 to 1750 mm bone saw blades 10 pcs box</i>	FSG110			
Ricambio <i>accessories</i> anelli per segaossa mm. 1760-2000 confezione da 10 <i>1760 to 2000 mm bone saw blades 10 pcs box</i>	FSG111			



SOTTOVUOTO A BARRA SALDANTE

BAR VACUUM PACKAGING MACHINE

• Macchinario per uso professionale • Aspirazione esterna ad azione manuale • Vacuometro a lancetta con indicazione del tempo reale e il grado di vuoto raggiunto • Possibilità di usare sia buste lisce che goffrate • Pompa per vuoto auto lubrificata che non richiede manutenzione • Scheda elettronica • Tensione 220 • Norme CE • Fabbriato in Italia

• Professional equipment • Manual external suction • Needle Vacuum measurer • Suitable for smooth and embossed vacuum bags • Self-lubricated Vacuum pump that won't require routine maintenance • Electronic control board • 220 voltage • CE approved • Proudly Made in Italy



	Alimentazione Power supply (Volt/Hz)	Potenza Motor power (Kwatt/Hp)	Pompa per vuoto autolubrificata Vacuum pump (L/min)	Struttura Structured in
FSV 32 T	230 / 50	0,40 (0,55)	15	ABS
FSV 32 IT	230 / 50-60	0,40 (0,55)	15	Inox
FSV 33 IF	230 / 50-60	0,38 (0,50)	13	

FSV 32 T ABS

<.....>

Barra saldante
Sealing bar (mm)
330 mm



Peso netto
Net weight (kg)
5,0 kg



Dimensioni prodotto
Product dimension (mm)
B. 370 / D. 300 / H. 160



FSV 32 IT INOX

<.....>

Barra saldante
Sealing bar (mm)
330 mm



Peso netto
Net weight (kg)
7,0 kg



Dimensioni prodotto
Product dimension (mm)
B. 360 / D. 290 / H. 150



FSV 33 IF INOX

<.....>

Barra saldante
Sealing bar (mm)
330 mm



Peso netto
Net weight (kg)
6,0 kg



Dimensioni prodotto
Product dimension (mm)
B. 390 / D. 300 / H. 180



NORME CE / CE APPROVED

Confezionatrice sottovuoto ABS mm.320
ABS Vacuum packer 320mm welding bar
codice prodotto product code

FSV32T

Confezionatrice sottovuoto INOX mm.320
S/steel Vacuum packer 320mm welding bar
codice prodotto product code

FSV32IT

Confezionatrice sottovuoto INOX mm.330
S/steel Vacuum packer 330mm welding bar
codice prodotto product code

FSV33IF



SOTTOVUOTO A BARRA SALDANTE

BAR VACUUM PACKAGING MACHINE

- Macchinario per uso professionale • Struttura in acciaio inox AISI 304
- Aspirazione esterna ad azione manuale • Elettrovalvola di fine ciclo
- Vacuometro a lancetta con indicazione della pressione e regolazione del tempo di saldatura • Pannello comandi di tipo elettromeccanico • Possibilità di usare sia buste lisce che goffrate • Pompa per vuoto auto lubrificata che non richiede manutenzione • Scheda elettronica • Tensione 220
- Norme CE • Fabbricato in Italia

- Professional equipment • Entirely structured in AISI 304 s/steel • Manual external suction • Cycle ending electric valve • Needle Vacuum measurer • Electromechanical control panel • Suitable for smooth and embossed vacuum bags • Self-lubricated Vacuum pump that won't require routine maintenance • Electronic control board • 220 voltage • CE approved • Proudly Made in Italy



	Alimentazione Power supply (Volt/Hz)	Potenza Motor power (Kwatt/Hp)	Pompa per vuoto autolubrificata Vacuum pump (L/min)	Struttura Structured in
FSV 35 IT	230 / 50	0,40 (0,55)	16	inox
FSV 45 IT	230 / 50	0,50 (0,70)	25	
FSV 52 IT	230 / 50-60	0,55 (0,75)	30	

FSV 35 IT INOX

<.....>

Barra saldante
Sealing bar (mm)
380 mm



Peso netto
Net weight (kg)
8,0 kg



Dimensioni prodotto
Product dimension (mm)
B. 425 / D. 260 / H.150



FSV 45 IT INOX

<.....>

Barra saldante
Sealing bar (mm)
430 mm



Peso netto
Net weight (kg)
10,0 kg



Dimensioni prodotto
Product dimension (mm)
B. 480 / D. 240 / H. 140



FSV 52 IT INOX

<.....>

Barra saldante
Sealing bar (mm)
550 mm



Peso netto
Net weight (kg)
24,0 kg



Dimensioni prodotto
Product dimension (mm)
B. 770 / D. 280 / H. 290



NORME CE / CE APPROVED

Confezionatrice sottovuoto INOXmm.350
Bar vacuum packaging machine INOX mm.350
codice prodotto product code

FSV35IT

Confezionatrice sottovuoto INOXmm.450
Bar vacuum packaging machine INOX mm.450
codice prodotto product code

FSV45IT

Confezionatrice sottovuoto INOXmm.520
Bar vacuum packaging machine INOX mm.520
codice prodotto product code

FSV52IT



SOTTOVUOTO A CAMPANA

BELL SHAPED VACUUM PACKAGING MACHINE

- Macchinario per professionale • Struttura in acciaio inox AISI 304 • Aspirazione interna ad azione automatica • Elettrovalvola di fine ciclo per riapertura automatica • Vacuometro a lancetta con indicazione del tempo reale • Comandi digitali • Possibilità di usare sia buste lisce che gofrate • Pompa per vuoto auto lubrificata che non richiede manutenzione • Controllo elettronico del ciclo • Scheda elettronica digitale monoprogramma • Microinterruttore per partenza automatica del ciclo di lavoro ad abbassamento del coperchio • Ferma campana • Carter apribile a 90° per favorire la manutenzione • Tensione 220 • Norme CE • Fabbriato in Italia

- Professional equipment • Structured in grade AISI 304 s/steel • Cycle ending electric valve • Needle Vacuum measurer • Digital display control • Suitable for smooth and embossed vacuum bags • Self-lubricated Vacuum pump that won't require routine maintenance • Electronic process control • Single-program digital electronic card • Automatic cut-off microswitch for lowered working cycle • Bell stop • 220 voltage • CE approved • Proudly Made in Italy



	Alimentazione Power supply (Volt/Hz)	Potenza Motor power (Kwatt/Hp)	Dimensione Camera Chambre dimensions (mm)	Pulsometro Pulsometer (mq/h)
FSCV 300	230 / 50	0,40 (0,55)	310x350x160	Q=10
FSCV 350		0,45 (0,60)	360x400x190	Q=12
FSCV 400		0,95 (1,30)	410x450x200	Q=20

FSCV 300

<.....>

Barra saldante
Sealing bar (mm)
300 mm



Peso netto
Net weight (kg)
42,0 kg



Dimensioni prodotto
Product dimension (mm)
B. 460 / D. 410 / H. 420



FSCV 350

<.....>

Barra saldante
Sealing bar (mm)
350 mm



Peso netto
Net weight (kg)
50,0 kg



Dimensioni prodotto
Product dimension (mm)
B. 460 / D. 500 / H. 420



FSCV 400

<.....>

Barra saldante
Sealing bar (mm)
400 mm



Peso netto
Net weight (kg)
55,0 kg



Dimensioni prodotto
Product dimension (mm)
B. 510 / D. 560 / H. 450



NORME CE / CE APPROVED

Confezionatrice sottovuoto a campana mm.300
Bell shaped vacuum packaging machine mm.300
codice prodotto product code

FSCV300

Confezionatrice sottovuoto a campana mm.350
Bell shaped vacuum packaging machine mm.350
codice prodotto product code

FSCV350

Confezionatrice sottovuoto a campana mm.400
Bell shaped vacuum packaging machine mm.400
codice prodotto product code

FSCV400

BUSTE GOFFRATE PER SOTTOVUOTO 105 MICRON

105 MICRON EMBOSSED VACUUM BAGS

Confezione da 100 pezzi / 100 pcs box

FSV 1255 - 120x550

FSV 1435 - 140x350

FSV 1530 - 150x300

FSV 1535 - 150x350

FSV 1623 - 160x230

FSV 2030 - 200x300

FSV 2040 - 200x400

FSV 2535 - 250x350

FSV 2550 - 250x500

FSV 3035 - 300x350

FSV 3040 - 300x400

FSV 3545 - 350x450

FSV 3570 - 350x700

FSV 30100 - 300x1000

FSV 4050 - 400x500

FSV 4070 - 400x700

FSV 5060 - 500x600

BUSTE LISCE PER COTTURA 90 MICRON

90 MICRON SMOOTH VACUUM BAGS FOR COOKING

Confezione da 100 pezzi - Riescono a mantenere fino 120° / 100 pcs box - Up to 120°

FSV 2030C - 200x300

FSV 2535C - 250x350

FSV 3040C - 300x400

BUSTE GOFFRATE PER COTTURA 105 MICRON

105 MICRON EMBOSSED VACUUM BAGS FOR COOKING

Confezione da 100 pezzi - Riescono a mantenere fino 150° / 100 pcs box - Up to 150°

FSV 1530 GC - 150x300

FSV 2030 GC - 200x300

FSV 2040 GC - 200x400

FSV 2535 GC - 250x350

FSV 2550 GC - 250x500

FSV 3040 GC - 300x400

FSV 3050 GC - 300x500

FSV 4050 GC - 400x500

FSV 4060 GC - 400x600





TERMOSIGILLATRICE HEATSEALER MACHINE

• Le termosigillatrici sono macchine studiate per il settore della gastronomia e della ristorazione professionale • Le nostre termosigillatrici compatte hanno la funzione di sola saldatura, rapida e sicura • Funzionamento manuale • Struttura della macchina completamente in acciaio inox • Display digitale • Multiform incluso • Norme CE • Fabbricate in Italia

• Professional equipment • Fast and safe welding • Manual operation • Stainless steel structure • Digital display • Multiform included • CE approved • Proudly Made in Italy



	Alimentazione Power supply (Volt/Hz)	Potenza Motor power (Kwatt/Hp)	Dimensione max vasca 1 Max tray dimensions 1 (mm)	Dimensione max vasca 2 Max tray dimensions 2 (mm)	Dimensione max vasca 3 Max tray dimensions 3 (mm)	Spessore pellicola Film thickness (µm)
200	110 V-60 Hz 220/230 V-50/60 Hz	0.7	190 x 260 mm	190 x 230 mm	190x137 mm	65

200

<.....>

Dimensione bobina
Film reel dimensions (mm)
200 x ø 200



Peso netto
Net weight (kg)
15,0 kg



Dimensioni prodotto
Product dimension (mm)
256 x 670 x 630h mm



FINO 3 VASCHEE INSIEME
UP TO THREE TRAYS TOGETHER

NORME CE / CE APPROVED

Termosigillatrice 200
Heatsealer machine 200
codice prodotto *product code*

FTRM20

Bobina 200 mm
Film reel 200 mm
codice prodotto *product code*

FBOB20



PRESSHAMBURGER MANUAL BURGER PRESS

- Macchinario per uso professionale • Struttura in lega di alluminio alimentare anodizzata • Porta cellophane incorporato • Contenitore carne in acciaio inox aisi 304 • Cremagliera in acciaio inox • Ingranaggi in acciaio
- Fondo in plastica • Attrezzo manuale di semplice utilizzo • Macchina molto robusta • Norme CE • Fabbriato in Italia

- Professional equipment • Structured in food-grade anodized aluminium alloy • Cellophane case included • AISI 304 stainless steel meat bowl • S/steel rack • Steel gears • Plastic bottom base • User friendly machine • Strong equipment • CE approved • Proudly Made in Italy



Peso hamburger - Hamburger weight (kg)

100 da 70 a 150 gr

130 da 150 a 250 gr

DUAL da 70 a 250 gr

100



Cilindro
Cylinder (mm)
Ø 100



Peso netto
Net weight (kg)
4,5 kg



Dimensioni prodotto
Product dimension (mm)
B. 190 / D. 250 / H. 320



130



Cilindro
Cylinder (mm)
Ø 130



Peso netto
Net weight (kg)
4,5 kg



Dimensioni prodotto
Product dimension (mm)
B. 190 / D. 300 / H. 280



DUAL



Cilindro
Cylinder (mm)
Ø 100/130



Peso netto
Net weight (kg)
5,5 kg



Dimensioni prodotto
Product dimension (mm)
B. 190 / D. 300 / H. 280



Ø 100 E 130
DISCHI INTERCAMBIABILI
INTERCHANGEABLE DISCS

PRESSHAMBURGER 100 Ø 100 mm.

codice prodotto product code

PRESSHAMBURGER 130 Ø 130 mm.

codice prodotto product code

PRESSHAMBURGER DUAL Ø 100/130 mm.

codice prodotto product code

confezione carta 1kg. (Ø 100 mm.) cellophane discs (1 kg pack)

codice prodotto product code

confezione carta 1kg. (Ø 130 mm.) cellophane discs (1 kg pack)

codice prodotto product code

NORME CE / CE APPROVED

FHA100

FHA400

FHA500

FHA101

FHA201



LAVORAZIONE PASTA

bakery and pasta making



PARTNER INFATICABILI
VERI STRUMENTI DA LAVORO

TIRELESS PARTNER
A REAL WORKING TOOL

MACCHINE PER LA PASTA FRESCA
PASTA MACHINES

IMPASTATRICI A SPIRALE TESTA FISSA
SPIRAL DOUGH MIXER KNEADER

IMPASTATRICI SERIE TESTA SOLLEVABILE
LIFTABLE HEAD DOUGH MIXERS

STENDIPIZZA
PIZZA SHAPING MACHINE

SFOGLIATRICI
DOUGH SHEETER





MACCHINA PER LA PASTA PASTA MACHINE

- Macchina professionale per produzione di pasta fresca • Ideale per piccola, media, grande ristorazione, di ridotto ingombro ma professionale
- Struttura in acciaio • Norme CE • Fabbriata in Italia

Dopo aver versato gli ingredienti nella vasca, la macchina impasta automaticamente per cinque minuti circa, poi inizia la trafilazione (invertitore in posizione 2). Si avrà così in pochissimi minuti pasta nei vari formati inserendo la trafila desiderata.

- Professional machine for homemade fresh pasta production • Ideal for small, medium, large catering, professional with space saving size • Steel structure • CE approved • Made in Italy

Pour the ingredients into the tank and the machine starts kneading for five minutes and shapes different Italian pasta variations (place inverter on position 2), depending on the pasta mould chosen.



	Alimentazione Power supply (Volt/Hz)	Potenza Motor power (Kwatt/Hp)	Produzione oraria Production per hour (kg/h)	Produzione minima Minimum production (kg)	Capacità vasca Tank capacity (kg)
FMPM 102	230/50*	0,4	5,0	0,5	1,5
FMPM 100		0,6	8,0	1,0	2,5
FMPM 100T		0,6	8,0	1,0	2,5
FMPM 101	230 - 400/50*	0,8	13,0	1,5	4,0

* 230/60 disponibile con sovrapprezzo - 230/60 available at extra cost

MINI



Peso netto
Net weight (kg)
17,5 kg



Dimensioni prodotto
Product dimension (mm)
B. 200 / D. 480 / H. 290



CHIAVE SVITA-GHIERA
UNSCREWING KEY

MEDIA

MEDIUM



Peso netto
Net weight (kg)
30,0 kg



Dimensioni prodotto
Product dimension (mm)
B. 260 / D. 600 / H. 350



MEDIA CON TAGLIAPASTA

WITH PASTA CUTTER - MEDIUM



Peso netto
Net weight (kg)
30,0 kg



Dimensioni prodotto
Product dimension (mm)
B. 260 / D. 600 / H. 350



CHIAVE SVITA-GHIERA
UNSCREWING KEY

GRANDE CON TAGLIAPASTA

WITH PASTA CUTTER - LARGE



Peso netto
Net weight (kg)
42,0 kg



Dimensioni prodotto
Product dimension (mm)
B. 280 / D. 650 / H. 450



UNITÀ TAGLIA-PASTA
PASTA CUTTER UNIT

NORME CE / CE APPROVED

MINI 230V monofase single phase

codice prodotto product code

MEDIA 230V monofase single phase

codice prodotto product code

MEDIA C/TAGLIAPASTA 230V monofase single phase

codice prodotto product code

GRANDE C/TAGLIAPASTA 230-400V trifase three phase

codice prodotto product code

Trifase / Three phase V. 230/400

Monofase / Single phase V. 230

FMPM102

FMPM100

FMPM100T

FMPM101

Le trafile sono costruite in bronzo, permettendo così di preservare nella pasta una porosità tale favorire la presa del condimento e mantenere quell'aspetto casereccio tanto ricercato. La macchina lavora con tutti i tipi di farina.

Bronze moulds that preserve pasta porosity for better sauce cling and keep the homemade appearance. All types of flour can be used.



AVVERTENZE
WARNING

Mantenere le trafile a bagno dopo l'utilizzo
Store the moulds in the water after use

TRAFILE PER MACCHINA PER LA PASTA MINI

PASTA MACHINE DRAWN - MINI



CASERECCÉ
FT01S



FUSILLI
FT02S



PAPPARDELLE
FT03S



GNOCCHI
FT04S



BUCATINI
FT05S



MACCHERONI
FT06S



CAPELLI D'ANGELO
FT07S



SPAGHETTI
FT08S



TAGLIOLINI
FT09S



TAGLIATELLE
FT10S



PASTA SFOGLIA
FT11S



GRAMIGNA
FT12S



BIGOLI
FT13S



CHITARRA
FT14S



CANNELLONI
FT15S

TRAFILE PER MACCHINA PER LA PASTA MEDIA E GRANDE

PASTA MACHINE DRAWN - MEDIUM AND LARGE



CASERECCÉ
FT16L



FUSILLI
FT17L



PAPPARDELLE
FT18L



GNOCCHI
FT19L



BUCATINI
FT20L



MACCHERONI
FT21L



CAPELLI D'ANGELO
FT22L



SPAGHETTI
FT23L



TAGLIOLINI
FT24L



TAGLIATELLE
FT25L



PASTA SFOGLIA
FT26L



GRAMIGNA
FT27L



BIGOLI
FT28L



CHITARRA
FT29L



CANNELLONI
FT30L

CONSIGLIO PER L'USO

RECOMMENDATIONS FOR USE

Per poter ottenere un corretto impasto occorre tenere presente che per ogni kg. di farina servono circa 380cl. di liquido (uova, acqua, verdure passate, ecc); una volta versata la farina e poi il liquido nella vasca, si chiude il coperchio e si mette in funzione la macchina. Per l'impasto si può usare qualsiasi tipo di farina, di grano, di semola o misto semola-farina di grano. Può succedere che la farina, a seconda del luogo e della temperatura in cui venga conservata, necessiti di una piccola correzione di acqua da aggiungere o sottrarre all'impasto. Si prevede, inoltre, che il peso medio di un uovo sia di 50g e che per ogni uovo in meno che si metta nell'impasto occorra versare 50 cl. di acqua. I tempi di impasto variano dai 5 ai 8 minuti.

To correctly make the dough, remember that about 300 cl. of liquid (eggs, water, vegetable juice, etc.) are required for each kg. of flour. After introducing the flour and pouring the liquid in the basin. Any type of flour, can be used for the dough - whole wheat, bran or meal. According to where and at what temperature the flour is kept, it may require slightly more or less water to make the dough. On average, an egg weighs 50 g and can be substituted for 50 cl. of water. Kneading time varies from 5 to 8 minutes.

Per ottenere un buon impasto rispettare i seguenti consigli:

The following recommendations are provided to obtain good dough quality:

FARINA FLOUR	+	LIQUIDO LIQUID	=	(UOVA EGGS	+	ACQUA WATER)
0,5 kg	+	190 gr	=	🥚 x 4	+	💧 0 gr	
1,0 kg	+	380 gr	=	🥚 x 7	+	💧 30 gr	
1,5 kg	+	570 gr	=	🥚 x 11	+	💧 20 gr	
2,0 kg	+	760 gr	=	🥚 x 15	+	💧 10 gr	
3,0 kg	+	1140 gr	=	🥚 x 23	+	💧 0 gr	





IMPASTATRICE DA BANCO TABLE-TOP DOUGH MIXER

Trasmissione a catena • Alberi di trasmissione di grosso spessore in acciaio • Pulegge e corone di produzione nazionale • Micro meccanico al coperchio • Vasca, spirale e asta in acciaio inox • Facile da pulire • Comandi a 24 volt • Norme CE • Fabbricata in Italia

Heavy duty durable chain transmission dough kneader • Stiffened Steel Transmission shaft • Italian made pulley and ring • Safety micro switch on the lid • Stainless steel bowl, tank and shaft • Easy to clean • 24volt control panel ensures safety during operation and gives the operator maximum security • CE approved • Proudly Made in Italy

5KG TESTA FISSA



Dimensione vasca
Bowl dimensions (mm)
ø 250x160



Peso netto
Net weight (kg)
23,0 kg



Dimensioni prodotto
Product dimension (mm)
B. 250 / D. 450 / H. 350



5KG TESTA SOLLEVABILE



Dimensione vasca
Bowl dimensions (mm)
ø 250x160



Peso netto
Net weight (kg)
27,0 kg



Dimensioni prodotto
Product dimension (mm)
B. 250 / D. 450 / H. 350



	Alimentazione Power supply (Volt/Hz)	Potenza Motor power (KW)	Volume vasca Tank diameter (lt)	Capacità d'impasto Dough output (kg)	Capacità farina Flour capacity (kg)
5 KG	230/50	0,37	7	5	3

NORME CE / CE APPROVED

Monofase / Single phase V. 230

5 KG 0,37 Kw - 7 litri - testa fissa

codice prodotto product code

FI7M

5 KG 0,37 Kw - 7 litri - testa sollevabile

codice prodotto product code

FIA7M

IMPASTATRICE A SPIRALE TESTA FISSA

FIXED HEAD DOUGH MIXERS



• Macchinario per uso professionale • Vasca, coperchio grigliato della vasca, asta spaccapasta e spirale in acciaio inox • Trasmissione a catena • Micro di sicurezza su coperchio • Comandi laterali • Norme CE

• Professional equipment • Bowl, bowl protection grid, rod and spiral made of stainless steel • Chain transmission • Interlocked bowl protection grid • Lateral control panel • CE approved



4KG



Dimensioni prodotto
Product dimension (mm)
B. 495 / D. 302 / H. 385

	Alimentazione Power supply (Volt/Hz)	Potenza Motor power (Kwatt/Hp)	Dimensione vasca Tank diameter (lt)	Capacità d'impasto Dough output (kg)	Peso netto Net weight (kg)
4 KG	230/50	0,45	8	4	36

NORME CE / CE APPROVED

F18MTM

4 KG 0,45 Kw - 8 litri - testa fissa
codice prodotto product code





IMPASTATRICE A SPIRALE TESTA FISSA

SPIRAL DOUGH MIXER KNEADER

• Macchinario per uso professionale • Testa fissa • Robusta struttura in acciaio • Motoriduttore di grande potenza di produzione italiana • Trasmissione a catena • Alberi di trasmissione di grosso spessore in acciaio • Micro meccanico al coperchio • Vasca, spirale e asta in acciaio inox • Ruote con freno di serie • Facile da pulire • Norme CE • Fabbricato in Italia

• Professional equipment • With fixed head • Stainless steel and enameled bodywork • Powerful and durable Italian make motor reducer • Heavy duty durable chain transmission dough kneader • Stiffened Steel Transmission shaft • Safety micro switch on the lid • Stainless steel bowl, tank and shaft • Wheels with brake included • Easy to clean • CE approved • Proudly Made in Italy



8 KG



Dimensione vasca
Bowl dimensions (mm)
ø 260



Peso netto
Net weight (kg)
42,0 kg



Dimensioni prodotto
Product dimension (mm)
B. 290 / D. 590 / H. 580



	Alimentazione Power supply (Volt/Hz)	Potenza Motor power (KW)	Volume vasca Tank diameter (lt)	Capacità d'impasto Dough output (kg)	Capacità farina Flour capacity (kg)	Altezza ruote Wheel size (cm)
8 KG	230/50	0,37	10	8,0	4	8,5
17 KG	230/50 230-400/50	0,75	22	17,0	8,5	
25 KG		1,10	32	25,0	12,5	
35 KG		1,10	41	35,0	17,5	
42 KG		1,50	48	42,0	21,0	

17KG



Dimensione vasca
Bowl dimensions (mm)
ø 360



Peso netto
Net weight (kg)
63,0 kg



Dimensioni prodotto
Product dimension (mm)
B. 385 / D. 670 / H. 725



25KG



Dimensione vasca
Bowl dimensions (mm)
ø 400



Peso netto
Net weight (kg)
94,0 kg



Dimensioni prodotto
Product dimension (mm)
B. 435 / D. 750 / H. 810



35KG



Dimensione vasca
Bowl dimensions (mm)
ø 450



Peso netto
Net weight (kg)
98,0 kg



Dimensioni prodotto
Product dimension (mm)
B. 480 / D. 820 / H. 850



42KG



Dimensione vasca
Bowl dimensions (mm)
ø 450



Peso netto
Net weight (kg)
105,0 kg



Dimensioni prodotto
Product dimension (mm)
B. 480 / D. 805 / H. 850



NORME CE / CE APPROVED

	Trifase / Three phase V. 230/400	Monofase / Single phase V. 230
8 KG 0,37 Kw - 10 litri codice prodotto <i>product code</i>		FI10M
17 KG 0,75 Kw - 22 litri codice prodotto <i>product code</i>	FI20T	FI20M
17 KG doppia velocità <i>double speed</i> codice prodotto <i>product code</i>	FI20TDV	
25 KG 1,10 Kw - 32 litri codice prodotto <i>product code</i>	FI30T	FI30M
25 KG doppia velocità <i>double speed</i> codice prodotto <i>product code</i>	FI30TDV	
35 KG 1,10 Kw - 41 litri codice prodotto <i>product code</i>	FI40T	FI40M
35 KG doppia velocità <i>double speed</i> codice prodotto <i>product code</i>	FI40TDV	
42 KG 1,50 Kw - 48 litri codice prodotto <i>product code</i>	FI50T	FI50M
42 KG doppia velocità <i>double speed</i> codice prodotto <i>product code</i>	FI50TDV	



IMPASTATRICE A SPIRALE TESTA SOLLEVABILE

LIFTABLE HEAD DOUGH MIXERS

• Macchinario per uso professionale • Testa sollevabile • Robusta struttura in acciaio • Motoriduttore di grande potenza di produzione italiana • Trasmissione a catena • Alberi di trasmissione di grosso spessore in acciaio • Micro meccanico al coperchio • Vasca, spirale e asta in acciaio inox • Vasca estraibile • Ruote con freno di serie • Facile da pulire • Norme CE • Fabbricato in Italia

• Professional equipment • With manual liftable head • Stainless steel and enameled bodywork • Powerful and durable Italian make motor reducer • Heavy duty durable chain transmission dough kneader • Stiffened Steel Transmission shaft • Safety micro switch on the lid • Stainless steel bowl, tank and shaft • Removable tank • Wheels with brake included • Easy to clean • CE approved • Proudly Made in Italy



8 KG



Dimensione vasca
Bowl dimensions (mm)
ø 260



Peso netto
Net weight (kg)
57,0 kg



Dimensioni prodotto
Product dimension (mm)
B. 300 / D. 600 / H. 645



	Alimentazione Power supply (Volt/Hz)	Potenza Motor power (Kw)	Volume vasca Tank diameter (lt)	Capacità d'impasto Dough output (kg)	Capacità farina Flour capacity (kg)	Altezza ruote Wheel size (cm)
8 KG	230/50	0,37	10	8,0	4,0	8,5
17 KG	230/50 230-400/50	0,75	22	17,0	8,5	
25 KG		1,10	32	25,0	12,5	
35 KG		1,10	41	35,0	17,5	
42 KG		1,50	48	42,0	21,0	

17KG



Dimensione vasca
Bowl dimensions (mm)
ø 360



Peso netto
Net weight (kg)
81,0 kg



Dimensioni prodotto
Product dimension (mm)
B. 390 / D. 670 / H. 735



25KG



Dimensione vasca
Bowl dimensions (mm)
ø 400



Peso netto
Net weight (kg)
100,0 kg



Dimensioni prodotto
Product dimension (mm)
B. 435 / D. 750 / H. 810



35KG



Dimensione vasca
Bowl dimensions (mm)
ø 450



Peso netto
Net weight (kg)
115,0 kg



Dimensioni prodotto
Product dimension (mm)
B. 480 / D. 815 / H. 850



42KG



Dimensione vasca
Bowl dimensions (mm)
ø 450



Peso netto
Net weight (kg)
121,0 kg



Dimensioni prodotto
Product dimension (mm)
B. 480 / D. 800 / H. 850



NORME CE / CE APPROVED

	Trifase / Three phase V. 230/400	Monofase / Single phase V. 230
8 KG 0,37 Kw - 10 litri codice prodotto <i>product code</i>		FIA10M
17 KG 0,75 Kw - 22 litri codice prodotto <i>product code</i>	FIA20T	FIA20M
17 KG doppia velocità <i>double speed</i> codice prodotto <i>product code</i>	FIA20TDV	
25 KG 1,10 Kw - 32 litri codice prodotto <i>product code</i>	FIA30T	FIA30M
25 KG doppia velocità <i>double speed</i> codice prodotto <i>product code</i>	FIA30TDV	
35 KG 1,10 Kw - 41 litri codice prodotto <i>product code</i>	FIA40T	FIA40M
35 KG doppia velocità <i>double speed</i> codice prodotto <i>product code</i>	FIA40TDV	
42 KG 1,50 Kw - 48 litri codice prodotto <i>product code</i>	FIA50T	FIA50M
42 KG doppia velocità <i>double speed</i> codice prodotto <i>product code</i>	FIA50TDV	

IMPASTATRICE A SPIRALE TESTA FISSA

FIXED HEAD DOUGH MIXERS



• Macchinario per uso professionale • Vasca, coperchio grigliato della vasca e asta spaccapasta, spirale in acciaio inox • Trasmissione a catena • Micro di sicurezza su coperchio • Comandi laterali con arresto di emergenza • Norme CE

• Professional equipment • Bowl, bowl protection grid, rod and spiral made of stainless steel • Chain transmission • Interlocked bowl protection grid • Lateral control panel with emergency stop button • CE approved



8KG



Dimensioni prodotto
Product dimension (mm)
B. 312 / D. 586 / H. 576

	Alimentazione Power supply (Volt/Hz)	Potenza Motor power (Kwatt/Hp)	Dimensione vasca Tank diameter (mm)	Volume vasca Tank output (lt)	Capacità d'impasto Dough output (kg)	Capacità farina Flour capacity (kg)	Altezza ruote Wheel size (cm)	Peso netto Net weight (kg)
8KG	230/50	0,55	ø260	10	8	4	8,5	52
18KG	230•400/50	1,1	ø355	20	18	9		78
25KG		1,5	ø410	30	25	12,5		106
38KG		2,2	ø450	40	38	19		138



IMPASTATRICE A SPIRALE TESTA FISSA

FIXED HEAD DOUGH MIXERS



18KG



Dimensioni prodotto
Product dimension (mm)
B. 381 / D. 736 / H. 685



25KG



Dimensioni prodotto
Product dimension (mm)
B. 432 / D. 778 / H. 750



38KG



Dimensioni prodotto
Product dimension (mm)
B. 480 / D. 875 / H. 755

NORME CE / CE APPROVED

8 KG 0,55 Kw - 10 litri

codice prodotto product code

18 KG 1,1 Kw - 20 litri

codice prodotto product code

18 KG doppia velocità double speed

codice prodotto product code

25 KG 1,5 Kw - 30 litri

codice prodotto product code

25 KG doppia velocità double speed

codice prodotto product code

38 KG 2,2 Kw - 40 litri

codice prodotto product code

38 KG doppia velocità double speed

codice prodotto product code

Trifase / Three phase V. 230/400

Monofase / Single phase V. 230

FI10MTM

FI20TTM

FI20MTM

FI20DVTM

FI30TTM

FI30MTM

FI30DVTM

FI40TTM

FI40MTM

FI40DVTM

imported

IMPASTATRICE A SPIRALE TESTA SOLLEVABILE

SPIRAL DOUGH MIXER LIFTABLE HEAD



• Macchinario per uso professionale • Vasca, coperchio grigliato della vasca e asta spaccapasta, spirale in acciaio inox • Trasmissione a catena • Micro di sicurezza su coperchio • Comandi laterali con arresto di emergenza • Norme CE

• Professional equipment • Bowl, bowl protection grid, rod and spiral made of stainless steel • Chain transmission • Interlocked bowl protection grid • Lateral control panel with emergency stop button • CE approved



18KG



Dimensioni prodotto
Product dimension (mm)
B. 395 / D. 753 / H. 690

	Alimentazione Power supply (Volt/Hz)	Potenza Motor power (Kwatt/Hp)	Dimensione vasca Tank diameter (mm)	Volume vasca Tank output (lt)	Capacità d'impasto Dough output (kg)	Capacità farina Flour capacity (kg)	Peso netto Net weight (kg)
18KG	230•400/50	1,1	ø360	20	18	9	97
25KG		1,5	ø410	30	25	12,5	134
38KG		2,2	ø450	40	38	19	167



IMPASTATRICE A SPIRALE TESTA SOLLEVABILE

SPIRAL DOUGH MIXER LIFTABLE HEAD



25KG



Dimensioni prodotto
Product dimension (mm)
B. 445 / D. 795 / H. 760



38KG



Dimensioni prodotto
Product dimension (mm)
B. 485 / D. 875 / H. 765

NORME CE / CE APPROVED

18 KG 1,1 Kw - 20 litri

codice prodotto product code

18 KG doppia velocità double speed

codice prodotto product code

25 KG 1,5 Kw - 30 litri

codice prodotto product code

25 KG doppia velocità double speed

codice prodotto product code

38 KG 1,5 Kw - 40 litri

codice prodotto product code

38 KG doppia velocità double speed

codice prodotto product code

Trifase / Three phase V. 230/400

Monofase / Single phase V. 230

FIA20TTM

FIA20MTM

FIA20DVTM

FIA30TTM

FIA30MTM

FIA30DVTM

FIA40TTM

FIA40MTM

FIA40DVTM

imported

PLANETARIE BAKER SERIE PM, PK

PLANETARY MIXERS BAKER PM, PK SERIES



PM5 PM7 • Macchinario per uso professionale • Struttura verniciata antigraffio • Vasca, uncino, spatola e frusta in acciaio inox AISI 304 • Coperchio vasca grigliato inox • Motore asincrono • Utensili e vasca a sgancio rapido • Variatore elettronico di velocità con trasmissione a cinghia ed ingranaggi • Testa sollevabile • Movimento planetario in grado di coprire tutto il volume della ciotola • Facilmente lavabili • In dotazione: vasca, uncino, spatola e frusta • Norme CE • **PK8** • Macchinario per uso professionale • Realizzate in metallo verniciato in smalto cotto inalterabile nel tempo • Motore asincrono ventilato • Termica di protezione • Trasmissione a ingranaggi • Micro alla protezione della vasca di lavorazione • Cambio a 3 velocità • Comandi frontali con pulsante di arresto • Vasca e frusta in acciaio inox AISI 304 • Uncino e spatola in alluminio • Utensili e vasca a sgancio rapido • Movimento planetario in grado di coprire tutto il volume della ciotola • Facilmente lavabili • In dotazione: vasca, uncino, spatola e frusta • Norme CE

PM5 PM7 • Professional equipment • Scratch resistant painted body • Bowl, hook, beater and whisk in AISI 304 stainless steel • AISI 304 bowl protection grid • Asynchronous motor • Tools and bowl with quick unlock mechanism • Electronic speed regulator, transmission with gears and belt • Liffable head • Easy to clean up • Standard equipment: bowl, hook, beater and whisk • CE approved • **PK8** • Professional equipment • Durable enameled bodywork • Asynchronous ventilated motor • Thermal overload protection included • Gears transmission • Fully CE approved with an electrically interlocked • Three speeds • Frontal controls with emergency stop button • Bowl and whisk in AISI 304 stainless steel • Hook and beater in aluminium • Tools and bowl with quick unlock mechanism • Easy to clean up • Standard equipment: bowl, hook, beater and whisk • CE approved

BakerPM

PM 5

Dimensioni prodotto
Product dimension (mm)
B. 230 mm / D. 350 mm / H. 400 mm

BakerPM

PM 7

Dimensioni prodotto
Product dimension (mm)
B. 250 mm / D. 420 mm / H. 420 mm

BakerPK

PK 8

Dimensioni prodotto
Product dimension (mm)
B. 280 mm / D. 470 mm / H. 580 mm



	Alimentazione Power supply (Volt/Hz)	Assorbimento Power input (Kwatt)	Velocità Speed (RPM)	Dim.ciotola Bowl dimensions (mm)	Capacità Capacity	Pasta frolla Pastry (kg)	Pan di spagna Sponge cake	Albumi d'uova Egg whites	Peso netto Net weight (kg)
PM 5	230 / 50	0,30	40/250	ø205x170	5	0,8	5 uova/eggs	7	13
PM 7		0,325	40/250	ø235x205	7	1,0	7 uova/eggs	10	15
PK 8		0,35	132/234/421	ø228x225	8	1,2	10 uova/eggs	12	21

NORME CE / CE APPROVED

Monofase / Single phase V. 230

PM 5 0,3 Kw

codice prodotto product code

PGM5

PM 7 0,325 Kw

codice prodotto product code

PGM7

PK 8 0,35 Kw

codice prodotto product code

PM8.01



PLANETARIE SERIE BAKER PA

PLANETARY MIXERS BAKER PA SERIES



- Macchinario per uso professionale • Struttura in ghisa verniciata • Vasca, protezione grigliata della vasca, uncino, spatola e frusta in acciaio • Motore prestante • Cambio meccanico a 3 velocità • Trasmissione a cinghia • Micro di sicurezza su vasca e protezione grigliata • Comandi con pulsante di arresto a fungo frontali • Movimento planetario in grado di coprire tutto il volume della ciotola • Facilmente lavabili • In dotazione: Vasca, uncino, spatola e frusta • Norme CE

- Professional equipment • Painted cast iron structure • Bowl, whisk, beater, hook and bowl protection grid made of stainless steel • Powerful motor • Three speeds • Belt transmission • Fully CE approved with an electrically interlocked • Controls with emergency stop button • Easy to clean up • Standard equipment: bowl, hook, beater and whisk • CE approved

BAKER PA



PA 10

Dimensioni prodotto
Product dimension (mm)
B. 490 mm / D. 400 mm / H. 780 mm



PA 20

Dimensioni prodotto
Product dimension (mm)
B. 590 mm
D. 480 mm
H. 930 mm



PA 30

Dimensioni prodotto
Product dimension (mm)
B. 680 mm
D. 590 mm
H. 1100 mm



PA 40

Dimensioni prodotto
Product dimension (mm)
B. 700 mm
D. 610 mm
H. 1130 mm



	Alimentazione Power supply (Volt/Hz)	Assorbimento Power input (Kwatt)	3 Velocità 3 Speed (RPM)	Dim.ciotola Bowl dimensions (mm)	Capacità Capacity	Pasta frolla Pastry (kg)	Pan di spagna Sponge cake	Albumi d'uova Egg whites	Peso netto Net weight (kg)
PA 10	230/50 - 230-400/50	0,60	118/234/460	ø240x240	10	1,5	10 uova/eggs	14	64,0
PA 20									
PA 30	230-400/50	1,30	134/234/460	ø360x320	30	5,0	45 uova/eggs	48	160,0
PA 40									

NORME CE / CE APPROVED

PA 10 0,6 Kw
codice prodotto product code

PA 20 0,9 Kw
codice prodotto product code

PA 30 1,3 Kw
codice prodotto product code

PA 40 1,3 Kw
codice prodotto product code

Trifase / Three phase V. 230/400	Monofase / Single phase V. 230
PAT10	PAM10
PAT20	PAM20
PAT30	
PAT40	



PLANETARIE SERIE BAKERLINE

PLANETARY MIXERS BAKERLINE SERIES



• Macchinario per uso professionale • Struttura in ghisa ed alluminio • Vasca, protezione grigliata della vasca e frusta in acciaio AISI 304 • Spatola e uncino in alluminio A356 • Motore asincrono ventilato adatto ad un lavoro pesante e continuativo • Cambio a 3 velocità • Trasmissione a ingranaggi • Micro di sicurezza su vasca e protezione grigliata • Comandi frontali con pulsante di arresto a fungo • Timer 0-15 minuti con posizione per funzionamento manuale su tutti i modelli • Movimento planetario in grado di coprire tutto il volume della ciotola • Facilmente lavabili • In dotazione: vasca, uncino, spatola e frusta • Norme CE

• Professional equipment • Cast iron and aluminium body • Bowl, bowl's protection grid and whisk in AISI 304 stainless steel • Beater and hook in A356 aluminium • Ventilated motor for a hard and continuous work • Three speeds • Gears transmission • Security switches on bowl and protection grid • Frontal controls with emergency stop button • 0-15 minutes timer on all models with manual functioning position • Easy to clean up • Standard equipment: bowl, hook, beater and whisk • CE approved



BAKERLINE 10



BAKERLINE 20



BAKERLINE 30

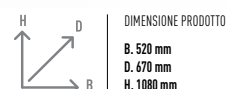

	Alimentazione Power supply (Volt/Hz)	Potenza Motor power (Kwatt/Hp)	3 Velocità 3 Speed	Dimensione vasca Bowl dimensions (mm)	Capacità d'impasto Dough output (kg)	Peso netto Net weight (kg)
BAKERLINE 10	230/50 - 230-400/50	0,37	95/175/320	ø245x240	10	65
BAKERLINE 20		0,55		ø320x300	20	97
BAKERLINE 30		0,75		ø370x350	30	198

NORME CE / CE APPROVED

Trifase / Three phase V. 230/400 | Monofase / Single phase V. 230

PB 10 0,37 Kw

codice prodotto product code

PBT10

PBM10

PB 20 0,55 Kw

codice prodotto product code

PBT20

PBM20

PB 30 0,75 Kw

codice prodotto product code

PBT30

PBM30



• Macchinario per uso professionale • Struttura in metallo pressofuso • Movimento planetario originale (lo sbattitore ruota in una direzione mentre mescola e gira nell'altra, in modo che gli ingredienti vengono costantemente portati verso il centro della ciotola) • Motore a spazzole • Trasmissione a ingranaggi • 10 velocità disponibili • Frusta in acciaio inox, uncino e spatola in alluminio smaltato (PK 4,5 - PK 5) • Frusta, uncino e spatola in acciaio inox (PK 7) • Vasca in acciaio inox smontabile • Ampia gamma di accessori • Facilmente lavabili • In dotazione: vasca, uncino, spatola e frusta • Norme CE

• Professional equipment • Painted metal structure • Original planetary motion • Motor with brush • Gears transmission • 10 speeds • Whisk AISI 304 stainless steel, Hook and beater glazed aluminium (PK 4,5 - PK 5) • Whisk, hook and beater AISI 304 stainless steel (PK 7) • Stainless steel removable bowl • Wide range of accessories • Easy to clean up • Standard equipment: bowl, hook, beater and whisk • CE approved

PK 7

Dimensioni prodotto
Product dimension (mm)
B. 340 mm / D. 370 mm / H. 420 mm



PK 5

Dimensioni prodotto
Product dimension (mm)
B. 280 mm / D. 360 mm / H. 420 mm



PK 4.5

Dimensioni prodotto
Product dimension (mm)
B. 220 mm / D. 350 mm / H. 350 mm



	Alimentazione Power supply (Volt/Hz)	Assorbimento Power input (Kwatt)	Velocità Speed (RPM)	Dim.ciotola Bowl dimensions (mm)	Capacità Capacity	Pasta frolla Pastry (kg)	Pan di spagna Sponge cake	Albumi d'uova Egg whites	Peso netto Net weight (kg)
PK 4,5	230 / 50-60	0,275	58/220	ø210x150	4,5	0,7	5 uova /egg	7	10,5
PK 5		0,325	58/220	ø210x170	5,2	0,8	6 uova/egg	8	12,0
PK 7		0,50	40/200	ø240x180	6,9	1,0	8 uova/egg	10	13,0

NORME CE / CE APPROVED

Monofase / Single phase V. 230

PK 4.5 codice prodotto product code	PK45
PK 5 codice prodotto product code	PK50
PK 7 codice prodotto product code	PK70





IKFGA
Tritacarne
Grinder



IKMVSA
Grattugia a cilindro
Dotata di tre cilindri per: affettare (verdure), taglio medio (julienne grattugiare pane), taglio grosso (mozzarella, grattugiare parmigiano)
Slicer with three cylinders: slice (vegetables), medium cut (julienne grate bread), coarse cut (mozzarella, grated parmesan)



IKSSA
Insaccatrice
Sausage stuffer



IKEMVSC
Set 3 cilindri per grattugia
sminuzzare finemente, purè, bastoncini julienne
*3 cylinders set for grater
Finely chop, mashed potatoes, julienne sticks*



IKPRA
Set pasta sfogliatrice + 2 tagli
(tagliatelle - tagliolini)
*Pasta set sheeter + 2 cuts
(tagliatelle - tagliolini)*



IKPEXTA
Pasta corta 6 trafile + accessori
(non disponibile per 6,9 Lt. CE)
*6 pasta extruders + accessories
(Not available on 6,9 Lt. CE)*



IKPSA
Rullo sfoglia singolo
Roll pastry single



IKFVSP
Passaverdure
Vegetable strainer



IKJE
Spremiagrumi
(non disponibile per PK70)
*Juicer
(Not available on PK70)*



IKSM1JA
Estrattore lento
(non disponibile per PK70)
*Juicer and sauce attachment
(Not available on PK70)*



IKICAOWH
Gelatiera
Ice cream bowl



IKGMA
Macina cereali
Grain mill



PK45SBWH
Ciotola senza manico - 4,28 Lt. per PK45
Bowl with handle - 4,28 Lt. for PK45



IK5ASB
Ciotola con manico - 4,83 Lt. per PK50
Bowl with handle - 4,83 Lt. for PK50



IKC7SB

Ciotola con manico 6,9 Lt. - per PK70
Bowl with handle 6,9 Lt. - for PK70



IK45SBWH

Ciotola con manico 4,28 Lt. - per PK45
Bowl with handle 4,28 Lt. - for PK45

ACCESSORI PK45
ACCESSORIES PK45



IK45WW
Frusta | Whip



IK45B
Spatola | Spatula



IK45DH
Uncino | Hook



IKN1PS
Coperchio versatore | Pourer cover

ACCESSORI PK50
ACCESSORIES PK50



IK5AWW
Frusta | Whip



IK5AB
Spatola | Spatula



IK5ADH
Uncino | Hook



IK5APSC
Coperchio versatore | Pourer cover



IK5BC5N
Coperchio ciotola | Bowl cover

ACCESSORI PK70
ACCESSORIES PK70



IKFE7T
Spatola con bordo flessibile
Flexible edge spatula



IK7EW
Frusta ellittica inox
S. steel elliptical whip



IK7SFB
Spatola inox
S. steel spatula



IK7FB
Spatola smaltata
Enamelled spatula



IK7SDH
Gancio inox | S. steel Hook



IK7DH
Gancio smaltato | Enamelled Hook



IK7PS
Coperchio versatore | Pourer cover

ACCESSORI PK70
ACCESSORIES PK70



PGMA002
Fusta PGM5 | PGM5 Whisk



PGMA007
Spatola PGM5 | PGM5 Spatula



PGMA006
Uncino PGM5 | SPGM5 Hook



PGMA009
Fusta PGM7 | PGM7 Whisk



PGMA022
Spatola PGM7 | PGM7 Spatula



PGMA004
Uncino PGM7 | SPGM7 Hook



STENDIPIZZA

PIZZA MOULDER

- Macchinario per uso professionale • Corpo interamente in acciaio inox AISI 304 (alberi portarulli compresi) • Coppia di rulli regolabili, per una precisione millimetrica dello spessore desiderato • Sistema di imbocco dell'impasto sui rulli inferiori facilitato da un altro rullo a folle • Protezione rulli • Ingranaggi dei riduttori realizzati con resine speciali, stampati e non dentati, per una durata cinque volte superiore al normale • Rinforzi interni per evitare qualsiasi flessione della carcassa • Pedale e predisposizione elettrica (optional) • Norme CE • Fabbricato in Italia

- Professional equipment • Body entirely made of steel (including the roller shaft) • One pair of adjustable rollers for you to get a sheet of dough as many millimetres thick as you like • A system of lower rollers and an idle roller favour the process of putting the dough into the machine • Separate roller protector • Transformers have gears made of special resins; they have been pressed, instead of indented, so as to last five times more than normal ones • Internal reinforcements to prevent the frame from bending • Electric pedal (optional) • CE approved • Proudly Made in Italy



30 HALF



Diametro pizza
Pizza base diameter (cm)
10/30



Peso netto
Net weight (kg)
22,0 kg



Dimensioni prodotto
Product dimension (mm)
B. 420 / D. 420 / H. 370



	Alimentazione Power supply (Volt/Hz)	Potenza Motor power (Kwatt/Hp)	Peso porzione d'impasto Dough portion size (g)	Max regolazione rulli Roller regulation ranger (mm)
30 HALF	230/50	0,37 (0,50)	50/700	0÷4
40 HALF			50/1000	
30			50/700	
40			50/1000	
40 RULLI PARAL.			50/1000	

40 HALF



Diametro pizza
Pizza base diameter (cm)
10/40



Peso netto
Net weight (kg)
25,0 kg



Dimensioni prodotto
Product dimension (mm)
B. 520 / D. 520 / H. 370



30



Diametro pizza
Pizza base diameter (cm)
10/30



Peso netto
Net weight (kg)
34,0 kg



Dimensioni prodotto
Product dimension (mm)
B. 420 / D. 420 / H. 700



40



Diametro pizza
Pizza base diameter (cm)
10/40



Peso netto
Net weight (kg)
40,0 kg



Dimensioni prodotto
Product dimension (mm)
B. 520 / D. 520 / H. 800



40 RULLI PARALLELI



Diametro pizza
Pizza base diameter (cm)
10/40



Peso netto
Net weight (kg)
40,0 kg



Dimensioni prodotto
Product dimension (mm)
B. 520 / D. 520 / H. 690



	NORME CE / CE APPROVED	SENZA NORME CE / NON CE APPROVED
	Monofase / Single phase V. 230	Monofase / Single phase V. 230
30 HALF 0,37 Kw (0,50 Hp) codice prodotto product code	FSPM100	FSPM100E
40 HALF 0,37 Kw (0,50 Hp) codice prodotto product code	FSPM200	
30 0,37 Kw (0,50 Hp) codice prodotto product code	FSPE100	FSPE100E
40 0,37 Kw (0,50 Hp) codice prodotto product code	FSPE200	FSPE200E
40 Rulli PARALLELI 0,37 Kw (0,50 Hp) codice prodotto product code	FSPE201	FSPE201E
FSP 202 pedale per stendipizza pizza moulder pedal codice prodotto product code	FSP202	



SFOGLIATRICE MANUALE / ELETTRICA MANUAL / ELECTRIC DOUGH SHEETER

• Macchinario per uso professionale • Struttura in acciaio inox AISI 304 • Ingranaggi in acciaio temperato ruotanti su perni rettificati • Boccole autolubrificanti • Pomello regolatore con indicatore numerato per 10 diversi spessori di sfoglia • Disponibile set per tagliare la pasta • Facile da pulire • Comandi a 24 volt (elettrica) • Norme CE • Fabbriato in Italia

• Professional equipment • Stiffened AISI 304 • Gears in tempered steel turning on ground pins • Self-lubricating bearings • Regulator knob with numbered indicator for 10 thicknesses of past sheet • Different size cutting tools available • Easy clean up • 24 volt control (electric) • CE approved • Proudly Made in Italy



	Alimentazione Power supply (Volt/Hz)	Potenza Motor power (Kwatt/Hp)	Velocità rotazione rulli Rotating speed rollers (rpm)	Max regolazione rulli Roller regulation ranger (mm)
MANUALE	-	-	-	0÷5
ELETTRICA	230/50	0,19 (0,25)	45	

MANUALE

MANUAL

<.....>

Max larghezza sfoglia
Max width pasta sheet (mm)
210



Peso netto
Net weight (kg)
9,3 kg



Dimensioni prodotto
Product dimension (mm)
B. 350 / D. 220 / H. 275



ELETTRICA

ELECTRIC

<.....>

Max larghezza sfoglia
Max width pasta sheet (mm)
210



Peso netto
Net weight (kg)
15,0 kg



Dimensioni prodotto
Product dimension (mm)
B. 200 / D. 300 / H. 250



FSE - TAGLIO PER SFOGLIATRICE

FSE PASTA CUTTER ACCESSORY



N.1
CAPELLI D'ANGELO 1,5 mm
THIN NOODLES 1,5 mm



N.2
TAGLIATELLE 2 mm
TAGLIATELLE 2 mm



N.3
TRENETTE 4 mm
TRENETTE 4 mm



N.4
FETTUCCINE 6,5 mm
RIBBON-SHAPED PASTA 6,5 mm



N.5
LASAGNETTE 12 mm
LASAGNETTE 12 mm



N.6
SPAGHETTI ø2 mm
SPAGHETTI ø2 mm



N.7
REGINETTE 12 mm
REGINETTE 12 mm

NORME CE / CE APPROVED

	Manuale / Manual	Monofase / Single phase V. 230
sfogliatrice manuale manual dough sheeter codice prodotto product code	FSM100	
sfogliatrice elettrica electrical dough sheeter codice prodotto product code		FSEI100
sfogliatrice elettrica rulli ruvidi electrical rough dough sheeter codice prodotto product code		FSEI100R
N.1 capelli d'Angelo 1,5 mm codice prodotto product code		FSE001N
N.2 tagliatelle 2 mm codice prodotto product code		FSE002N
N.3 trenette 4 mm codice prodotto product code		FSE003N
N.4 fettuccine 6,5 mm codice prodotto product code		FSE004N
N.5 lasagnette 12 mm codice prodotto product code		FSE005N
N.6 spaghetti ø2 mm codice prodotto product code		FSE006N
N.7 reginette 12 mm codice prodotto product code		FSE007N



SFOGLIATRICE DOUGH SHEETER

• Macchinario per uso professionale • Struttura in acciaio inox e alluminio
• Cilindri in legno (per una sfoglia casalinga) oppure in acciaio (per una maggiore durata) • Motore ventilato • Termica di protezione • Regolazione spessore con leva • Facile da pulire • Comandi a 24 volt • Norme CE • Fabbricato in Italia

• Professional equipment • Stiffened AISI 304 and aluminium • Wooden rollers for home made type pasta or steel for longer preservation • Ventilated motor • Thermal overload protection • Thicknessing adjusting lever • Easy clean up • 24 volt control • CE approved • Proudly Made in Italy



	Alimentazione Power supply (Volt/Hz)	Potenza Motor power (Kwatt/Hp)	Max regolazione rulli Roller regulation ranger (mm)	Max larghezza sfoglia Max width pasta sheet (mm)
320	230/50 230-400/50	0,60 (0,80)	0÷7,5	350
400				400
500				500

320



Dimensione rullo
Roll dimensions (mm)
ø 55x320



Peso netto
Net weight (kg)
45,0 kg



Dimensioni prodotto
Product dimension (mm)
B. 550 / D. 350 / H. 400



400



Dimensione rullo
Roll dimensions (mm)
ø 55x400



Peso netto
Net weight (kg)
48,0 kg



Dimensioni prodotto
Product dimension (mm)
B. 640 / D. 350 / H. 400



500



Dimensione rullo
Roll dimensions (mm)
ø 55x500



Peso netto
Net weight (kg)
52,0 kg



Dimensioni prodotto
Product dimension (mm)
B. 750 / D. 450 / H. 450



NORME CE / CE APPROVED

320 0,6 Kw (0,8 Hp) Rulli inox cm 32 - 32 cm s/steel rolls

codice prodotto product code

320 0,6 Kw (0,8 Hp) Rulli legno cm 32 - 32 cm wooden rolls

codice prodotto product code

400 0,6 Kw (0,8 Hp) Rulli inox cm 40 - 40 cm s/steel rolls

codice prodotto product code

400 0,6 Kw (0,8 Hp) Rulli legno cm 40 - 40 cm wooden rolls

codice prodotto product code

500 0,6 Kw (0,8 Hp) Rulli inox cm 50 - 50 cm s/steel rolls

codice prodotto product code

FSTP tagliapasta misure 2-6-12

pasta cutter accessory av. in size 2-6-12

codice prodotto product code

Trifase / Three phase V. 230/400

Monofase / Single phase V. 230

FSE103

FSE103M

FSE101

FSE101M

FSE104

FSE104M

FSE102

FSE102M

FSE105

FSE105M

FSTP (ACCESSORIO)



SNACK BAR
snack bar



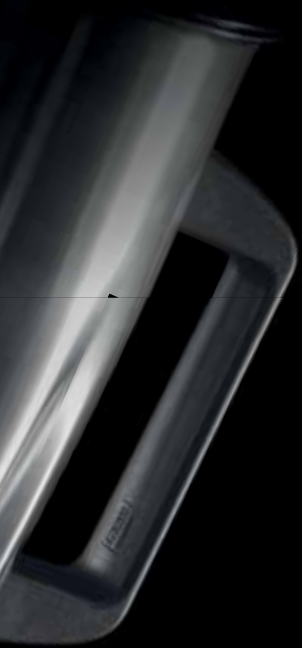

SERVIZIO COMPLETO
A PORTATA DI COCKTAIL

COMPLETE SERVICE
HANDY COCKTAIL

FRULLINI
DRINKS MIXERS

SPREMIAGRUMI
CITRUS JUICERS

FRULLATORI
BLENDERS

CENTRIFUGHE
CENTRIFUGAL
JUICE EXTRACTORS

TRITAGHIACCIO E
SPEZZAGHIACCIO
ICE SHAVERS

GRUPPI BAR
BAR UNITS

MACINACAFFÉ E GRATTUGIA
COMBO COFFEE GRINDER AND GRATER

PRESSAMELAGRANA
POMEGRANATE JUICER





FRULLINI DRINKS MIXERS

• Macchinario per uso professionale • Struttura in alluminio pressofuso e plastica • Motore ventilato • Bicchiere in acciaio inox o plastica • Due velocità • Farfalla in acciaio inox • Disponibile versione con bicchiere in plastica (cod. MF4T) • Norme CE • Fabbriato in Italia

• Professional equipment • Structured in plastic and pressure die cast aluminium • Ventilated motor • Grade stainless steel jug or in plastic • Two speed included • Stainless steel blending blades • CE approved • Proudly Made in Italy



	Alimentazione Power supply (Volt/Hz)	Potenza Motor power (Kwatt/Hp)	Velocità Speed (rpm)	Capacità Capacity (lt)
MF4	230 / 50-60	0,15 (0,20)	15.000	0,8
MF4T				
MF4D		0,15 (0,20) x2		0,8 x2
MF4DT				

MF 4 MF 4T



Peso netto
Net weight (kg)
3,0 kg



Dimensioni prodotto
Product dimension (mm)
B. 200 / D. 220 / H. 500

Disponibile con bicchiere
trasparente
Available with polycarbonate
container



MF 4D MF 4DT



Peso netto
Net weight (kg)
6,0 kg



Dimensioni prodotto
Product dimension (mm)
B. 330 / D. 220 / H. 500

Disponibile con bicchiere
trasparente
Available with polycarbonate
container



NORME CE / CE APPROVED

MF4 150W frullino semplice - bicchiere inox - 0,9 lt
150W single spindle mixer - s/steel container - 0,9 lt
codice prodotto product code

MF4

MF4T 150W frullino semplice - bicchiere trasparente - 0,9 lt
150W single spindle mixer - polycarbonate container - 0,9 lt
codice prodotto product code

MF4T

MF4D 2x150W frullino doppio - bicchiere inox - 0,9x2 lt
2x150W double spindle mixer - s/steel container - 0,9x2 lt
codice prodotto product code

MF4D

MF4DT 2x150W frullino doppio - bicchiere trasparente - 0,9x2 lt
2x150W double spindle mixer - polycarbonate container - 0,9x2 lt
codice prodotto product code

MF4DT



SPREMIAGRUMI CITRUS JUICER

- Macchinario per uso professionale • Struttura in alluminio pressofuso e verniciato • Passino in acciaio inox • Vasca di lavorazione rimovibile in ABS • Pigna in abs estraibile per il lavaggio • Microinterruttore sulla pigna • Basamento con sottobicchiere salva goccia • Paraspruzzi di serie • Norme CE • Fabbriato in Italia

- Professional equipment • Structured in pressure die cast and varnished aluminium • Removable ABS container • Removable ABS reamer for easy and effective cleaning • Safety switch activating • Drip-saving saucer base • Polycarbonate splash guard included for leverless models • CE approved • Proudly Made in Italy



	Alimentazione Power supply (Volt/Hz)	Potenza Motor power (Kwatt/Hp)	Velocità Speed (rpm)	Contenitore Jug (mm)	Ogiva Reamer
MSE	230 / 50-60	0,30 (0,40)	1400	220 / ABS	ABS
MSP				220 / INOX	
MSP 2		0,34 (0,45)		110 / INOX	INOX

MSE IN ABS



Peso netto
Net weight (kg)
6,0 kg



Dimensioni prodotto
Product dimension (mm)
B. 200 / D. 310 / H. 340



MSP INOX



Peso netto
Net weight (kg)
6,5 kg



Dimensioni prodotto
Product dimension (mm)
B. 220 / D. 310 / H. 340



MSP 2 INOX



Peso netto
Net weight (kg)
9,0 kg



Dimensioni prodotto
Product dimension (mm)
B. 220 / D. 310 / H. 350



NORME CE / CE APPROVED

MSE con vasca in ABS *ABS container*

codice prodotto *product code*

MSE

MSELIM ogiva limoni optional *optional lemon bowl*

codice prodotto *product code*

MSELIM

MSP con vasca in acciaio inox *s/steel container*

codice prodotto *product code*

MSP

IN DOTAZIONE, OGIVA ARANCE + OGIVA LIMONI *SUPPLIED WITH LEMON + ORANGE BOWL*

MSP2 a leva inox *s/steel citrus juicer with handle*

codice prodotto *product code*

MSP2



FRULLATORI CONTAINER BLENDERS

- Macchinario per uso professionale • Robusta struttura in alluminio pressofuso e verniciato • Motore ventilato • Micro al coperchio del bicchiere • Curato nei particolari • Linea filante per una facile pulizia • Norme CE • Fabbriato in Italia

- Professional equipment • Structured in a strong pressure die cast varnished aluminium • Ventilated motor • Safety micro switch assembled on the jug • High grade finishing • Jug and all other parts in contact with food removable for easy cleaning • CE approved • Proudly Made in Italy



	Alimentazione Power supply (Volt/Hz)	Potenza Motor power (Kwatt/Hp)	2 Velocità 2 Speed (rpm)	Capacità Capacity (lt)	Materiale bicchiere Blender container
MT1 SINGOLO	230 / 50-60	0,40 (0,55)	10000/15000	1,5	Policarbonato
MT1 D DOPPIO		0,40 (0,55) x2		1,5 x2	Policarbonato
MT1 I SINGOLO BICCH. INOX		0,40 (0,55)		1,5	INOX
MT1 I DOPPIO BICCH. INOX		0,40 (0,55) x2		1,5 x2	INOX
MTQ	230 / 50-60	0,75 (1,00)	8000/16000	2	Policarbonato
MT FIVE	230 / 50-60	0,75 (1,00)	8000/16000	5	INOX
MT5	230 / 50	0,80 (1,10)	3000	5	INOX

MT1



Peso netto
Net weight (kg)
4,0 kg



Dimensioni prodotto
Product dimension (mm)
B. 200 / D. 200 / H. 460



MT1 D



Peso netto
Net weight (kg)
8,0 kg



Dimensioni prodotto
Product dimension (mm)
B. 350 / D. 220 / H. 460



MT1 I INOX



Peso netto
Net weight (kg)
4,0 kg



Dimensioni prodotto
Product dimension (mm)
B. 200 / D. 220 / H. 460



MT1D I INOX



Peso netto
Net weight (kg)
7,5 kg



Dimensioni prodotto
Product dimension (mm)
B. 350 / D. 220 / H. 460



MTQ



Peso netto
Net weight (kg)
5,0 kg



Dimensioni prodotto
Product dimension (mm)
B. 208 / D. 210 / H. 490



MT FIVE



Peso netto
Net weight (kg)
7,0 kg



Dimensioni prodotto
Product dimension (mm)
B. 245 / D. 260 / H. 540



MT 5



Peso netto
Net weight (kg)
10,5 kg



Dimensioni prodotto
Product dimension (mm)
B. 230 / D. 230 / H. 530



	NORME CE / CE APPROVED
MT1 bicchiere trasparente polycarbonate blender container codice prodotto product code	MT1
MT1D doppio bicchiere trasparente polycarbonate double container codice prodotto product code	MT1D
MT1I bicchiere inox s/steel container codice prodotto product code	MT1I
MT1DI doppio bicchiere inox double s/steel container codice prodotto product code	MT1DI
MTQ bicchiere trasparente polycarbonate blender container codice prodotto product code	MTQ
MT5 bicchiere inox s/steel container codice prodotto product code	MT5
MT FIVE bicchiere inox s/steel container codice prodotto product code	MTFIVE



CENTRIFUGA CONTAINER BLENDERS

- Macchinario per uso professionale • Centrifuga autopulente con leva a doppio scatto • Motore con sonda termica • Corpo in alluminio lucido
- La grande bocca di carico permette di lavorare frutti larghi • Filtro e lame in acciaio inossidabile • Coperchio in plastica lavabile • Cestello in acciaio inossidabile lavabile • Cestello immediatamente estraibile per una più facile e veloce pulizia • Pestello in plastica • Velocità contenuta per salvaguardia proteine alimento • Facile da pulire • Norme CE • Fabbricato in Italia

- Professional equipment • Self-cleaning centrifugal juicer equipped with double click lever • Motor with thermal probe • Shiny aluminium body • The big hole in the cover allows to squeeze more large than 80 mm fruits • Blade and filter made from stainless steel • Plastic lid suitable for dish washer • Easy clean up stainless steel juicer basket • Immediately removable basket for a more quick and easy cleaning • Plastic pestle • Speed turning designed to save food proteins while processing • Easy clean up • CE approved • Proudly Made in Italy



MCF 100



Peso netto
Net weight (kg)
14,0 kg



Dimensioni prodotto
Product dimension (mm)
B. 270 / D. 450 / H. 550



Alimentazione
Power supply (Volt/Hz)

Potenza
Motor power (Kwatt/Hp)

Larghezza tubo inserimento
Feeder chute (cm)

MCF100

230 / 50-60

0,40 (0,55)

8

NORME CE / CE APPROVED

MCF100

MCF100 centrifuga centrifugal juicer
codice prodotto product code

CENTRIFUGA

CENTRIFUGAL JUICER



• Macchinario per uso professionale • Il corpo in acciaio inossidabile AISI 304 previene l'ossidazione del succo • Motore universale con raffreddamento ad aria • Il motore funziona unicamente se il coperchio è chiuso ed i fermi di bloccaggio della maniglia di sicurezza sono agganciati • Il cestello del filtro di alta qualità, con 6 rinforzi laterali, è particolarmente resistente • L'ampio tubo di inserimento permette di introdurre frutti interi o pezzi di verdura • Posizionando l'interruttore sulla modalità "Turbo", tutti i residui di frutta e verdura presenti nel cestello del filtro vengono rimossi • Pestello in plastica • Contenitore in plastica • Semplice da assemblare • Facile da pulire • Norme CE

• Professional equipment • The AISI 304 stainless steel body stops the juices oxidising • The air-cooled multipurpose motor is long-lasting and has a capacity of up to 60 kg of carrots per hour • The motor will only operate if the lid is on and the safety lock is operated • The high-quality basket sieve with 6 reinforcing ridges is superbly hard-wearing • A large feeder chute, 7.5 cm in diameter to squeeze whole fruit or pieces of vegetable • By pressing the turbo switch, any pieces of fruit or vegetable left in the basket sieve are removed • Plastic pestle • Plastic container • Simple to assemble • Easy clean up • CE approved

FCF100



Dimensioni prodotto
Product dimension (mm)
B. 190 / D. 310 / H. 380



	Alimentazione Power supply (Volt/Hz)	Assorbimento Power input (Kwatt)	Giri / m RPM	Capacità raccoltipolpa Capacity (lt)	Larghezza tubo inserimento Feeder chute (cm)	Produzione oraria Production per hour (lt/h)	Peso netto Net weight (kg)	Capacità Capacity
FCF 100	230 / 50-60	0,24	6300	3,25	7,5	60	4,2	650

NORME CE / CE APPROVED

FCF100

FCF100 centrifuga centrifugal juicer
codice prodotto product code



ESTRATTORI DI SUCCO

JUICE EXTRACTORS



• Macchinario per uso professionale • Motore potente e stabile • Bassa rumorosità • Coclea e filtro in ULTEM/PEI • Brocca di spremitura e contenitore di raccolta in TRITIUM • Max 30 minuti di funzionamento continuo • Lenta velocità di lavoro, utile a mantenere tutta la genuinità della spremitura e lasciando inalterate le proprietà organolettiche della frutta • Spremitura a freddo per produrre succo contenente enzimi e nutrienti superiori • Auto espulsione della polpa in eccesso durante la spremitura • 2 filtri intercambiabili, succhi di frutta vellutati e senza polpa (filtro fori piccoli), succhi con maggiore polpa (filtro fori grossi) (FES 100A optional, FES 102 e FES 104 di serie) • Funzione Reverse per evitare intasamenti • Doppio indotto (solo FES104) • Facile da pulire • Norme CE

• Professional equipment • Powerful and stable motor • The motor is very quiet • ULTEM/PEI screw and strainer • Squeeze jug and collection container in TRITIUM • Max 30 min use • The slow juicer also perfectly separates the pulp from the juice, making a beautiful pulp free juice • Cold pressed, to produce a superior enzyme and nutrient content juice • Low • Auto pulp ejection for continuous automatic juicing • 2 interchangeable filters (coarse screen, fine screen) (optional for FES 100A, included in FES 102 and FES 104) • Built in reverse function eliminates clogging for continuous juicing • Double inlet (only FES104) • Easy clean up • CE approved

FES 100 D.01 FES 100 D.02



Dimensioni prodotto
Product dimension (mm)
B. 208 / D. 228 / H. 450



FES 102 DOMESTICO



Dimensioni prodotto
Product dimension (mm)
B. 140 / D. 210 / H. 440



	Alimentazione Power supply (Volt/Hz)	Assorbimento Power input (Kwatt)	Giri /m RPM	Utilizzo continuativo Use (min)	Peso netto Net weight (kg)
FES 100	230 / 50-60	0,24	50	15	6,6
FES 102		0,15	65	(max 30)	6,8

NORME CE / CE APPROVED

Trifase / Three phase V. 230/400

FES100 D.01 Estrattore di succo / Juice extractor
codice prodotto product code

FES100D.01

FES100 D.02 Estrattore di succo / Juice extractor
codice prodotto product code

FES100D.02

FESF Coppia filtri - Kit Smoothie + Ice Cream
Juicer Filter (Pair) - Kit Smoothie + Ice Cream
codice prodotto product code

FESF

FES102 Estrattore di succo / Juice extractor
codice prodotto product code

FES102





TRITAGHIACCIO PER GRANITA ICE SHAVER FOR SLUSH DRINKS

- Macchinario per uso professionale • Indicato per tritare il ghiaccio per granita • Struttura in alluminio presso fuso verniciato • Micro di sicurezza al manico della bocca di carico • Lame taglia ghiaccio in acciaio inox • Motore ventilato • Norme CE • Fabbriato in Italia

- Professional equipment • Prepares ice for the preparation of slush or water ice • Structured in varnished pressure die cast aluminium • Safety micro switch assembled on the loading handle • Grade s/steel cutting blades • Ventilated motor • CE approved • Proudly Made in Italy



SPEZZAGHIACCIO PER COCKTAIL ICE CRUSHER FOR PREPARATION OF COCKTAIL

- Macchinario per uso professionale • Indicato per la preparazione di cocktails, pestati, long drinks • Corpo in alluminio lucido • Motore silenzioso dotato di sonda termica • Produce ghiaccio a scaglie di 4 dimensioni diverse grazie alla griglia di regolazione brevettata • Bicchiere in acciaio inox • Micro di sicurezza al coperchio • Lame taglia ghiaccio in acciaio inox • Motore silenzioso dotato di sonda termica • Norme CE • Fabbriato in Italia

- Professional equipment • Ideal to prepare cocktails and long drinks • Shiny aluminium body • The motor is very quiet and it is provided with thermal probe • Produce ice flakes in 4 different sizes thanks to a patented regulation system • Stainless steel glass • Micro switch blocks the rotation raising the cover • Grade s/steel cutting blades • The motor is very quiet and it is provided with thermal probe • CE approved • Proudly Made in Italy

MTG 6 PER GRANITA



Peso netto
Net weight (kg)
10,0 kg



Dimensioni prodotto
Product dimension (mm)
B. 210 / D. 420 / H. 290



Ghiaccio da granita
For the preparation of slush drinks

MSG 100 PER COCKTAIL



Peso netto
Net weight (kg)
10,0 kg



Dimensioni prodotto
Product dimension (mm)
B. 250 / D. 300 / H. 520



Ghiaccio da cocktail
Professional ice crusher for preparation of
cocktails in general and for garnish

NORME CE / CE APPROVED

MTG6 tritaggiaccio automatico *automatic ice shaver*
codice prodotto *product code*

MTG6

MSG100 spezzaggiaccio automatico *automatic ice shaver*
codice prodotto *product code*

MSG100

	Alimentazione Power supply (Volt/Hz)	Potenza Motor power (Kwatt/Hp)	Produzione oraria Prod. per hour (kg)	Giri/m (rpm)	Bicchieri Container
MTG 6	230 / 50	0,34 (0,45)	-	1400	-
MSG 100	230 / 50-60	0,45 (0,60)	120		INOX (2 lt)



GRUPPO BAR BAR UNITS ASSEMBLY

- Macchinario per uso professionale • Struttura in alluminio verniciato • Particolari in acciaio inox • Campane in plastica trasparente • Motori ventilati • Passino in acciaio inox • Vasca di lavorazione agrumi rimovibile in acciaio inox • Campana in poliestere infrangibile lavabile in lavastoviglie • Norme CE • Fabbriato in Italia

- Professional equipment • Structured in varnished aluminium • Stainless steel finishing • Transparent plastic tank • Stainless steel option is also available • Ventilated motors • Stainless steel filter • Removable s/steel reamer • Infrangible polyester tank suitable for dish washer • CE approved • Proudly Made in Italy



	Alimentazione Power supply (Volt/Hz)	Potenza frullatore Blender power (Kwatt/Hp)	Potenza tritaggiaccio Ice shaver power (Kwatt/Hp)	Potenza frullino Splinder mixer power (Kwatt/Hp)	Potenza spremiagrumi Fruji juicer power (Kwatt/Hp)
MG 10	230 / 50	0,40 (0,55)	0,34 (0,45)	0,15 (0,20)	-
MG 13			-	-	0,34 (0,45)
MG 15			-	0,15 (0,20)	
MG 20			-	-	
MG 50			0,34 (0,45)	0,15 (0,20)	

MG 13



Peso netto
Net weight (kg)
14,0 kg



Dimensioni prodotto
Product dimension (mm)
B. 190 / D. 440 / H. 460



MG 20



Peso netto
Net weight (kg)
24,0 kg



Dimensioni prodotto
Product dimension (mm)
B. 320 / D. 550 / H. 465



MG 50



Peso netto
Net weight (kg)
26,0 kg



Dimensioni prodotto
Product dimension (mm)
B. 320 / D. 550 / H. 490



NORME CE / CE APPROVED

MG10 tritaggiaccio 340W - spremiagrumi a leva 340W - frullino 150W

ice shaver 340W - citrus juicer 340W - drink mixer 150W

codice prodotto *product code*

MG10

MG13 spremiagrumi a leva 340W - frullatore 400W

citrus juicer 340W - blender 400W

codice prodotto *product code*

MG13

MG15 spremiagrumi a leva 340W - frullatore 400W - frullino 150W

citrus juicer 340W - blender 400W - drink mixer 150W

codice prodotto *product code*

MG15

MG20

tritaggiaccio 340W - spremiagrumi a leva 340W - frullatore 400W

ice shaver 340W - citrus juicer 340W - blender 400W

codice prodotto *product code*

MG20

MG50

tritaggiaccio 340W - spremiagrumi a leva 340W

frullatore 400W - frullino 150W

ice shaver 340W - citrus juicer 340W - blender 400W - drink mixer 150W

codice prodotto *product code*

MG50



COMBINATI MACINACAFFÈ COFFEE GRINDER

- Macchinario per uso professionale • Struttura in alluminio lucidato o verniciato • Macine in acciaio rokwell dotato di protezione termica • Campana in plastica infrangibile • Regolazione manuale alla campana • Macine in acciaio rettificato • Manopola regolazione spessore taglio • Ferma sacchetto • Pulsante avviamento digitale • Scheda elettronica a 24 volt • Norme CE • Fabbricato in Italia

- Professional equipment • Structured in polished or varnished aluminium • Rockwell s/steel grinding stone supplied with thermal protection • Infrangible plastic bowl • Manual adjustable bowl lever • Rectified steel grindstone • Adjustable cut thicknessing knob • Bag locking • Digital starting button • 24 volt control board • CE approved • Proudly Made in Italy



	Alimentazione Power supply (Volt/Hz)	Potenza frullatore Blender power (Kwatt/Hp)	Giri/m (rpm)	Produzione oraria caffè/pepe Coffee pepper prod. per hour (kg)
CS	230/50 230-400/50	0,75 (1,00)	1400	10,0
CD				10,0+10,0
GC				10,0
GCP				10,0+10,0

CS



Dimensioni mola
Grinding wheel dimensions (mm)
Ø 65



Peso netto
Net weight (kg)
17,0 kg



Dimensioni prodotto
Product dimension (mm)
B. 200 / D. 350 / H. 720



CD



Dimensioni mola
Grinding wheel dimensions (mm)
Ø 65



Peso netto
Net weight (kg)
19,0 kg



Dimensioni prodotto
Product dimension (mm)
B. 220 / D. 500 / H. 720



	NORME CE / CE APPROVED	SENZA NORME CE / NON CE APPROVED
CS macinacaffè o pepe 230/400V trifase <i>coffee or pepper grinder three phase 230/400V</i> codice prodotto <i>product code</i>	FCS105	
CS macinacaffè o pepe 230V monofase <i>coffee or pepper grinder single phase 230V</i> codice prodotto <i>product code</i>	FCS106	FCS101
CD macinacaffè o pepe 230/400V trifase versione doppia <i>double coffee or pepper grinder three phase 230/400V</i> codice prodotto <i>product code</i>	FCD105	
CD macinacaffè o pepe 230V monofase versione doppia <i>double coffee or pepper grinder single phase 230V</i> codice prodotto <i>product code</i>	FCD106	FCD101



MACINACAFFÈ COFFEE GRINDER

- Macchinario per uso professionale • Struttura in alluminio lucidato o verniciato • Campana in plastica infrangibile • Regolazione manuale alla campana • Macine in acciaio rettificato • Manopola regolazione spessore taglio • Ferma sacchetto • Pulsante avviamento digitale • Scheda elettronica a 24 volt • Norme CE • Fabbriato in Italia

- Professional equipment • Structured in polished or varnished aluminium • Infrangible plastic bowl • Manual adjustable bowl lever • Rectified steel grindstone • Adjustable cut thickness knob • Bag locking • Digital starting button • 24 volt control board • CE approved • Proudly Made in Italy

MACINADOSATORE COFFEE GRINDER AND DOSER

- Macchinario per uso professionale • Struttura in alluminio lucidato o verniciato • Campana in plastica infrangibile • Regolazione manuale alla campana • Macine in acciaio rettificato • Manopola regolazione spessore taglio • Ferma sacchetto • Pulsante avviamento digitale • Scheda elettronica a 24 volt • Dosatore per caffè • Disponibile versione: FMXT macinadosatore con temporizzatore • Disponibile versione: FMXA macinadosatore automatico • Norme CE • Fabbriato in Italia

- Professional equipment • Structured in polished or varnished aluminium • Infrangible plastic bowl • Manual adjustable bowl lever • Rectified steel grindstone • Adjustable cut thickness knob • Bag locking • Digital starting button • 24 volt control board • Coffee dispenser • Available: FMXT coffee grinder with timer • Available: FMXA automatic coffee grinder and doser • CE approved • Proudly Made in Italy



	Alimentazione Power supply (Volt/Hz)	Potenza Motor power (Kwatt/Hp)	Giri/m (rpm)	Produzione oraria caffè/pepe Coffee pepper prod. per hour (kg)
FMC 6	230/50	0,34 (0,45)	1400	3,0/4,0
FMX				

FMC 6



Dimensioni mola
Grinding wheel dimensions (mm)
Ø 65



Peso netto
Net weight (kg)
12,5 kg



Dimensioni prodotto
Product dimension (mm)
B. 230 / D. 370 / H. 600



FMX



Dimensioni mola
Grinding wheel dimensions (mm)
Ø 65



Peso netto
Net weight (kg)
13,0 kg



Dimensioni prodotto
Product dimension (mm)
B. 230 / D. 370 / H. 600



NORME CE / CE APPROVED

FMC6 macinacaffè motore *coffee grinder*
codice prodotto *product code*

FMC6

FMX macinadosatore *coffee grinder and doser*
codice prodotto *product code*

FMX

FMXT macinadosatore con temporizzatore *coffee grinder and doser*
codice prodotto *product code*

FMXT

FMXA macinadosatore automatico *aut. coffee grinder and doser*
codice prodotto *product code*

FMXA



PRESSAMELAGRANA MANUALE

MANUAL POMEGRANATE JUICER

• Funzionamento manuale • Tutta la parte spremente in acciaio inox è completamente rimovibile per la pulizia • La corsa della leva è studiata per richiedere il minor sforzo possibile nell'utilizzo • La base è profonda per dare stabilità • Norme CE • Fabbriato in Italia

• *Manual operation • The entire stainless steel part is completely removable for cleaning • The lever stroke is designed to require the least possible effort in use • The base is deep to give stability • CE approved • Proudly Made in Italy*



FPM



Peso netto
Net weight (kg)
3,0 kg



Dimensioni prodotto
Product dimension (mm)
B. 220 / D. 220 / H. 630



NORME CE / CE APPROVED

FPM

FPM pressamelagrana manuale *manual pomegranate juicer*
codice prodotto *product code*





COTTURA
cooking equipment



TUTTO PER LA CUCINA
ALL FOR KITCHEN

ROWNER
ROWNER

FRIGGITRICI
FRYERS

FORNI CONVEZIONE MECCANICI
MECHANICAL CONVECTION OVENS

FORNI CONVEZIONE DIGITALI
CON INIEZIONE ACQUA
DIGITAL CONVECTION OVENS
WITH WATER INJECTION

FORNI PER PIZZA
PIZZA OVENS

SALAMANDRE
SALAMANDERS

FORNETTI
SMALL OVENS

TOSTAPANE
TOASTER

ROLLER TOAST
ROLLER TOASTER

CREPIERA ELETTRICA
PANCAKE MACHINE

PIASTRE GRILL
E VETROCERAMICA
SANDWICH AND PYROCERAM GRILLS

FRY TOP ACCIAIO
E VETROCERAMICA
STAINLESS STEEL
AND PYROCERAM FRY TOP





RONER RONER

- Termocircolatore ad immersione • Ideale per cottura sottovuoto a bassa temperatura • Semplice da usare • Display LCD temperatura attuale • Display LCD impostazione temperatura/tempo • Pulsante di selezione temperatura • Pulsante di selezione tempo • Pulsante di avvio/pausa ciclo di lavoro • Pulsante di selezione dei valori • Norme CE • Fabbricato in Italia

- *Immersion thermal circulator for Sous Vide cooking • Easy to use • Current temperature LCD display • Temperature and time setting LCD display • Temperature setting button • Time setting button • Start / pause cycle button • Values selection button • CE approved • Proudly Made in Italy*



	Alimentazione <i>Power supply</i> (Volt/Hz)	Potenza <i>Motor power</i> (Kwatt)	Capacità massima <i>Max capacity</i> (lt)	Range temperature <i>Range</i> temperature (C°)	Programmi <i>Programs</i>	Avviso livello acqua minimo <i>Min. water level</i> warning	Avvio ritardato <i>Delayed start</i>	Allarme raggiungimento temp. cottura <i>Alarm for cooking</i> temp.reached level	Sonda al cuore (acc.) <i>Core probe</i> (acc.)	Sfere 250 pz. (acc.) <i>Spheres 250 pcs</i> (acc.)	Nastro adesivo Neoprene (acc.) <i>Neoprene tape</i> (acc.)
25 ECO	230 / 50	1,20	25,0	20 / 95	0	Sì	NO	Sì	Non disponibile <i>Not available</i>	Disponibile <i>Available</i>	Non disponibile <i>Not available</i>

25 ECO



Peso netto
Net weight (kg)
1,26 kg



Dimensioni prodotto
Product dimension (mm)
B. 80 / D. 160 / H. 370



NORME CE / CE APPROVED

RONER 25 ECO
codice prodotto *product code*

FROW25ECO

LA COTTURA SOTTOVUOTO

VACUUM COOKING

“Cottura sottovuoto”, con riferimento alla cucina, identifica alimenti che vengono cucinati a bassa temperatura all’interno di apposite buste sottovuoto per cottura. Prima di procedere con le fasi successive, è indispensabile confezionare il prodotto desiderato in apposite buste o rotoli per cottura sottovuoto goffrati in caso di utilizzo di macchine ad aspirazione esterna e buste o rotoli lisci in caso di utilizzo di macchine professionali a campana. Una volta confezionato l’alimento nell’apposito sacchetto sottovuoto, è sufficiente immergere la busta nell’acqua già in temperatura, per il tempo di cottura desiderato.

L’alimento viene protetto dal sacchetto e non entra a diretto contatto con l’ambiente esterno di cottura, pertanto, l’ossigeno non ha possibilità di penetrare all’interno e i cibi non rischiano di ossidarsi. Con la cottura sottovuoto gli alimenti non perdono il loro colore naturale e le loro proprietà nutritive: tutti i sapori restano all’interno della busta, così come tutte le vitamine e i sali minerali. Anche gli alimenti che in genere si scuriscono in cottura, restano del loro colore iniziale. La tecnica della cottura sottovuoto consente non solo di prolungare fino a tre volte la durata di conservazione del prodotto, poiché l’assenza di ossigeno rallenta la proliferazione batterica e l’ossidazione degli alimenti, ma viene soprattutto consigliata nelle diete in quanto permette di cucinare senza l’aggiunta di grassi.

VANTAGGI

- **Mantenimento proprietà organolettiche**
- **Riduzione del calo di peso in cottura**
- **Riduzione degli sprechi**
- **Risparmio economico**
- **Risparmio di tempo**
- **Barriera all’ossigeno e al vapore acqueo**
- **Prolungamento della durata di conservazione**

“Sous Vide” is a French term that means “under vacuum” and, with reference to the kitchen, identifies foods that are cooked in low temperature conditions inside special vacuum pouches for Sous Vide cooking. Before proceeding with the cooking process, it is essential to pack the desired product in special embossed cooking bags/ rolls - in case of use of external suction machines - and smooth cooking bags / rolls - in case of use of professional chamber machines. Once the food has been packaged in the special vacuum pouch, it is sufficient to immerse the bag in the water for the desired cooking time.

Food is protected from the bag and does not come into direct contact with the external cooking environment. In this way oxygen has no possibility to penetrate inside and the foods are not likely to oxidise. Thanks to Sous Vide foods do not lose their natural color, nor the nutritional properties and all the flavours remain inside as well as all the vitamins and minerals. The foods are therefore better, healthier and more colorful. Even foods that generally darken during cooking remain in their natural color. The Sous Vide technique allows to prolong the shelf life of the product up to three times, since the absence of oxygen slows down the proliferation of bacteria and the oxidation of food. Sous Vide is also recommended in diets because it allows you to cook without adding fat.

ADVANTAGES

- **Organoleptic properties maintenance**
- **Weight loss reduction**
- **Waste reduction**
- **Cost saving**
- **Time saving**
- **High barrier to oxygen and water vapor**
- **Shelf life extension**





FRIGGITRICI TANK FRYER

- Macchinario per uso professionale • Struttura realizzata con lamiera di acciaio inox • Vasca di cottura in acciaio inox • Vasca estraibile per lavaggio • Coperchio salva spruzzi in acciaio inox con maniglia in plastica • Capiente cestello in rete con manico per facile estrazione • Resistenze a lunga durata e removibili • Termostato di lavoro e di sicurezza (50-180°) • Raggiungimento temperatura immediato • Microinterruttore • Norme CE • Fabbriato in Italia

- Professional equipment • Structured in s/steel plate • Frying tank made from s/steel • Removable tank for cleaning • S/steel splash guard with plastic handle • Easy pull-out and capacious reticulated basket with handle • Heavy duty Heating elements • Working and safety thermostat (50-180°) • Fast oil heating • Micro switch • CE approved • Proudly Made in Italy



	Alimentazione Power supply (Volt/Hz)	Potenza Motor power (Kwatt/Hp)	Dimensione vasca Tank dimension (mm)	Rubinetto di scarico Drain valve	Capacità olio Oil capacity (lt)
MFR 40	230 / 50-60	2,0	140x240 h.100	NO	3
MFR 240		2,0x2	140x250 h.100 x2		3+3
MFR 80		3,25	220x240 h.100		6
MFR 280		3,25x2	220x240 h.100 x2		6+6

MFR 40 SINGOLA SINGLE



Peso netto
Net weight (kg)
5,0 kg



Dimensioni prodotto
Product dimension (mm)
B. 245 / D. 430 / H. 310



MFR 240 DOPPIA DOUBLE



Peso netto
Net weight (kg)
8,5 kg



Dimensioni prodotto
Product dimension (mm)
B. 430 / D. 430 / H. 310



MFR 80 SINGOLA SINGLE



Peso netto
Net weight (kg)
6,0 kg



Dimensioni prodotto
Product dimension (mm)
B. 340 / D. 430 / H. 310



MFR 280 DOPPIA DOUBLE



Peso netto
Net weight (kg)
11,0 kg



Dimensioni prodotto
Product dimension (mm)
B. 620 / D. 430 / H. 310



NORME CE / CE APPROVED

MFR40 2000 W

codice prodotto product code

MFR40

MFR240 2x2000 W

codice prodotto product code

MFR240

MFR80 3250 W

codice prodotto product code

MFR80

MFR280 2x3250 W

codice prodotto product code

MFR280



FRIGGITRICI TANK FRYER

- Macchinario per uso professionale • Struttura realizzata con lamiera di acciaio inox • Vasca di cottura in acciaio inox con rubinetto • Vasca estraibile per lavaggio • Coperchio salva spruzzi in acciaio inox con maniglia in plastica • Capiente cestello in rete con manico per facile estrazione • Resistenze a lunga durata e removibili • Termostato di lavoro e di sicurezza (50-180°) • Raggiungimento temperatura immediato • Microinterruttore • Norme CE • Fabbricato in Italia

- Professional equipment • Structured in s/steel plate • Frying tank made from s/steel with tap • Removable tank for cleaning • S/steel splash guard with plastic handle • Easy pull-out and capacious reticulated basket with handle • Heavy duty Heating elements • Working and safety thermostat (50-180°) • Fast oil heating • Micro switch • CE approved • Proudly Made in Italy



	Alimentazione Power supply (Volt/Hz)	Potenza Motor power (Kwatt/Hp)	Dimensione vasca Tank dimension (mm)	Rubinetto di scarico Drain valve	Capacità olio Oil capacity (lt)
MFR 80R	230 / 50-60	3,25	220x240 h.100	SI	6
MFR 280R		3,25x2	220x240 h.100 x2		6+6
MFR 10R		3,50	220x240 h.100		8
MFR 210R		3,50x2	220x240 h.100 x2		8+8

MFR 80 R

SINGOLA
SINGLE



Peso netto
Net weight (kg)
7,0 kg



Dimensioni prodotto
Product dimension (mm)
B. 340 / D. 430 / H. 355



MFR 280 R

DOPPIA
DOUBLE



Peso netto
Net weight (kg)
13,0 kg



Dimensioni prodotto
Product dimension (mm)
B. 620 / D. 430 / H. 355



MFR 10 R

SINGOLA
SINGLE



Peso netto
Net weight (kg)
8,5 kg



Dimensioni prodotto
Product dimension (mm)
B. 300 / D. 480 / H. 350



MFR 210 R

DOPPIA
DOUBLE



Peso netto
Net weight (kg)
16,0 kg



Dimensioni prodotto
Product dimension (mm)
B. 600 / D. 480 / H. 350



NORME CE / CE APPROVED

MFR80R 3250 W

codice prodotto product code

MFR80R

MFR280R 2x3250 W

codice prodotto product code

MFR280R

MFR10R 3500 W

codice prodotto product code

MFR10R

MFR210R 2x3500 W

codice prodotto product code

MFR210R



FRIGGITRICI TANK FRYER

- Macchinario per uso professionale • Struttura realizzata con lamiera di acciaio inox • Vasca di cottura in acciaio inox con rubinetto • Vasca estraibile per lavaggio • Coperchio salva spruzzi in acciaio inox con maniglia in plastica • Capiente cestello in rete con manico per facile estrazione • Resistenze a lunga durata e removibili • Termostato di lavoro e di sicurezza (50-180°) • Raggiungimento temperatura immediato • Microinterruttore • Norme CE • Fabbricato in Italia

- Professional equipment • Structured in s/steel plate • Frying tank made from s/steel with tap • Removable tank for cleaning • S/steel splash guard with plastic handle • Easy pull-out and capacious reticulated basket with handle • Heavy duty Heating elements • Working and safety thermostat (50-180°) • Fast oil heating • Micro switch • CE approved • Proudly Made in Italy



	Alimentazione Power supply (Volt/Hz)	Potenza Motor power (Kwatt/Hp)	Dimensione vasca Tank dimension (mm)	Rubinetto di scarico Drain valve	Capacità olio Oil capacity (lt)
MFR 12R	400 / 50-60	9,0	210x280 h.120	SI	12
MFR 212R		9,0x2	210x280 h.120 x2		12+12
MFR 12M		9,0	210x280 h.120		12
MFR 212M		9,0x2	210x280 h.120 x2		12+12

MFR 12 R

SINGOLA
SINGLE



Peso netto
Net weight (kg)
19,5 kg



Dimensioni prodotto
Product dimension (mm)
B. 400 / D. 700 / H. 420



MFR 212 R

DOPPIA
DOUBLE



Peso netto
Net weight (kg)
35,0 kg



Dimensioni prodotto
Product dimension (mm)
B. 800 / D. 700 / H. 420



MFR 12 M

SINGOLA
SINGLE



Peso netto
Net weight (kg)
31,0 kg



Dimensioni prodotto
Product dimension (mm)
B. 400 / D. 700 / H. 960



MFR 212 M

DOPPIA
DOUBLE



Peso netto
Net weight (kg)
54,0 kg



Dimensioni prodotto
Product dimension (mm)
B. 800 / D. 700 / H. 960



NORME CE / CE APPROVED

MFR12R 9000 W

codice prodotto product code

MFR12R

MFR212R 2x9000 W

codice prodotto product code

MFR212R

MFR12M 9000 W

codice prodotto product code

MFR12M

MFR212M 2x9000 W

codice prodotto product code

MFR212M



FORNO CONVEZIONE MECCANICO

MECHANICAL CONVECTION OVEN GRILL

• Macchinario per uso professionale • Interni ed esterni realizzati in acciaio inox • Illuminazione interna della camera • Camera di cottura saldata con angoli arrotondati • Porta doppio vetro (4 mm) • 2 ventole autoreverse da 2800 giri/min • Elevato isolamento termico da 50 mm • Base della camera di cottura diamantata per facilitare lo scarico della condensa interna • Cremagliera teglie removibile Norme CE • Fabbricato in Italia

• Professional equipment • Inside and outside made of stainless steel • Room interior lighting • Welded cooking chamber with rounded corners • Double glass door (4 mm) • 2800 rpm two-directional wheel fan • High performing 50 mm thermal insulation • Diamond wired cooking chamber base for easy condensation discharge • Removable tray • CE approved • Proudly Made in Italy



	Alimentazione Power supply (Volt/Hz)	Potenza Motor power (Kwatt/Hp)	Temperatura Temperature (°C)	Regolazione tempo Timer setting range (min)	Capacità camera Load capacity (mm)	Distanza teglie Distance between trays (mm)
FFM 100 S	230 / 50-60	2,8	10-280	1-120	4 x 433x333	70
FFM 101 G		3,5	50-300		4 x GN 2/3	
FFM 102 U		2,8				
FFM 103 C		3,3				4 x GN 1/1
FFM 103 PF		6,3	75			
FFM 105 C		7,7				

FFM 100S



Peso netto
Net weight (kg)
37,0 kg



Dimensioni prodotto
Product dimension (mm)
B. 557 / D. 585 / H. 563



FFM 101G CON GRILL



Peso netto
Net weight (kg)
35,5 kg



Dimensioni prodotto
Product dimension (mm)
B. 557 / D. 585 / H. 563



FFM 102U CON UMIDIFICATORE WITH HUMIDIFIER



Peso netto
Net weight (kg)
33,5 kg



Dimensioni prodotto
Product dimension (mm)
B. 557 / D. 585 / H. 568



FFM 103C CON UMIDIFICATORE WITH HUMIDIFIER



Peso netto
Net weight (kg)
52,0 kg



Dimensioni prodotto
Product dimension (mm)
B. 724 / D. 730 / H. 509



FFM 103PF CON UMIDIFICATORE WITH HUMIDIFIER



Peso netto
Net weight (kg)
59,0 kg



Dimensioni prodotto
Product dimension (mm)
B. 825 / D. 685 / H. 560



FFM 105C CON UMIDIFICATORE WITH HUMIDIFIER



Peso netto
Net weight (kg)
85,0 kg



Dimensioni prodotto
Product dimension (mm)
B. 830 / D. 710 / H. 710



	NORME CE / CE APPROVED
FFM100S standard codice prodotto <i>product code</i>	FFM100S
T100SG teglia per forno tray for oven codice prodotto <i>product code</i>	T100SG
G100SG griglia per forno griddle for oven codice prodotto <i>product code</i>	G100SG
FFM101G con grill with grill codice prodotto <i>product code</i>	FFM101G
T100SG teglia per forno tray for oven codice prodotto <i>product code</i>	T100SG
G100SG griglia per forno griddle for oven codice prodotto <i>product code</i>	G100SG
FFM102U con umidificatore with humidifier device codice prodotto <i>product code</i>	FFM102U
T102U teglia per forno tray for oven codice prodotto <i>product code</i>	T102U
G102U griglia per forno griddle for oven codice prodotto <i>product code</i>	G102U
FFM103C con umidificatore with humidifier device codice prodotto <i>product code</i>	FFM103C
T103C teglia per forno tray for oven codice prodotto <i>product code</i>	T103C
G103C griglia per forno griddle for oven codice prodotto <i>product code</i>	G103C
FFM103PF con umidificatore with humidifier device codice prodotto <i>product code</i>	FFM103PF
T103PFC teglia per forno tray for oven codice prodotto <i>product code</i>	T103PFC
G103PFC griglia per forno griddle for oven codice prodotto <i>product code</i>	G103PFC
FFM105C con umidificatore with humidifier device codice prodotto <i>product code</i>	FFM105C
T103PFC teglia per forno tray for oven codice prodotto <i>product code</i>	T103PFC
G103PFC griglia per forno griddle for oven codice prodotto <i>product code</i>	G103PFC





FORNO CONVEZIONE DIGITALE CON INIEZIONE ACQUA

DIGITAL CONVECTION OVEN WITH WATER INJECTION

- Apparecchio per uso professionale • Forno digitale a convezione con iniezione di acqua • Capienza 4 teglie o griglie GN 1/1 o 600x400 mm • Pannello di controllo digitale: doppio display, memoria 9 programmi di cottura, innesto per sonda al cuore, preriscaldamento, temperatura della camera di cottura, tempi di cottura, temperatura al cuore, percentuale di acqua iniettata nella camera di cottura, accensione e spegnimento delle luci interne • Porta rimovibile per facile manutenzione • Porta fredda con doppio vetro, apribile per massimizzare le operazioni di pulizia • Maniglia con sistema di apertura di sicurezza • Apertura porta con sicurezza anti-sbuffi di vapore e disattivazione ventola • Sistema di scarico acqua di condensa della porta e del forno • Camera di cottura in acciaio inox con angoli arrotondati • Guarnizioni con sistema di fissaggio ad incastro • Piedini antiscivolo • Norme CE • Fabbricato in Italia

- Professional equipment • Digital convection oven with water injection system • Suitable for 4 pans or grids GN 1/1 or 600x400 mm • Digital control pane: double display, possibility of memorizing up to 9 cooking programs, core probe input, pre-heating cooking room temperature, cooking time, core probe temperature, percentage of injected steam inside the cooking room, switch on/off of internal lights • Easy door replacement system • Maximization of the cleaning operations thanks to the foldable internal glass of the cold door • Handle with safety opening system • Door overture with anti-puffs and fan/s stop system • Door and oven condensed water system drain • Stainless steel cooking chamber with rounded corners • Interlocking gasket fixing system • Antislip feet • CE approved • Proudly Made in Italy



FFDU 4



Peso netto
Net weight (kg)
79,0 kg



Dimensioni prodotto
Product dimension (mm)
B. 840 / D. 910 / H. 670



	Alimentazione Power supply (Volt/Hz)	Potenza Motor power (Kwatt/Hp)	Temperatura Temperature (°C)	Dimensione camera Oven chamber size (mm)	Capacità camera Load capacity (mm)	Distanza teglie Distance between trays (mm)
FFDU 4	220-240 / 380-415	5,45	0-280	680x520x360	4-600x400 - 4-GN 1/1	80
FFDU 5		6,45		680x480x440	5-600x400 - 5-GN 1/1	
FFDU 6		7,65		680x440x520	6-600x400 - 6-GN 1/1	
FFDU 7		10,70		680x520x620	7-600x400 - 7-GN 1/1	
FFDU 10		12,70		680x480x840	10-600x400 - 10-GN 1/1	

FFDU 5



Peso netto
Net weight (kg)
87,0kg



Dimensioni prodotto
Product dimension (mm)
B. 840 / D. 910 / H. 750



FFDU 6



Peso netto
Net weight (kg)
91,0 kg



Dimensioni prodotto
Product dimension (mm)
B. 840 / D. 910 / H. 830



FFDU 7



Peso netto
Net weight (kg)
87,0kg



Dimensioni prodotto
Product dimension (mm)
B. 840 / D. 910 / H. 750



FFDU 10



Peso netto
Net weight (kg)
91,0 kg



Dimensioni prodotto
Product dimension (mm)
B. 840 / D. 910 / H. 830



	NORME CE / CE APPROVED
FFDU4 codice prodotto <i>product code</i>	FFDU4
FFDU5 codice prodotto <i>product code</i>	FFDU5
FFDU6 codice prodotto <i>product code</i>	FFDU6
FFDU7 codice prodotto <i>product code</i>	FFDU7
FFDU10 codice prodotto <i>product code</i>	FFDU10
FFDUT1 teglia per forno GN 1/1 <i>tray for oven GN 1/1</i> codice prodotto <i>product code</i>	FFDUT1
FFDUG1 griglia per forno GN 1/1 <i>griddle for oven GN 1/1</i> codice prodotto <i>product code</i>	FFDUG1
FFDUT6 teglia per forno 600x400 mm <i>tray for oven 600x400 mm</i> codice prodotto <i>product code</i>	FFDUT6
FFDUG6 griglia per forno 600x400 mm <i>griddle for oven 600x400 mm</i> codice prodotto <i>product code</i>	FFDUG6



FORNO A MICROONDE MICROWAVE OVEN

Compatto e performante il forno RMS offre affidabilità e durata nel professionale anche a budget di spesa ridotti • Studiato per carichi di lavoro medio bassi • Completa rispondenza alle norme • Prodotto per uso commerciale e professionale • Carcassa inox e interno inox • 1000 Watt di potenza resa con ottima distribuzione • Piatto fisso con distribuzione microonde a mezzo antenna rotante • Pratica e robusta maniglia apertura porta • Segnale cottura con volume regolabile • Pratico display a led • 5 livelli di potenza • 20 memorie per programmi di cottura con 3 differenti stadi • Funzione x2 • Pulsanti con alfabeto Braille • Norme CE

• Compact and high-performance, the RMS oven offers reliability and durability in the professional sector even at low cost budgets • Designed for medium-low workloads • Complete compliance with standards • Product for commercial and professional use • Stainless steel body and stainless steel interior • 1000 Watt power output with excellent distribution • Fixed plate with microwave distribution by rotating antenna • Practical and sturdy door opening handle • Cooking signal with adjustable volume • Practical LED display • 5 power levels • 20 memories for cooking programs with 3 different stages • x2 Function • Buttons with Braille alphabet • CE approved • Proudly Made in Italy



DECS 11M



Peso netto
Net weight (kg)
13,6 kg



Dimensioni prodotto
Product dimension (mm)
B. 310 / D. 483 / H. 394



NORME CE / CE APPROVED

DECS11M

DECS11M forno microonde digitale *microwave oven*
codice prodotto *product code*

	Alimentazione <i>Power supply (Volt/Hz)</i>	Potenza <i>Motor power (Kwatt/Hp)</i>	Dimensioni interne <i>Internal dimensions (mm)</i>	Frequenza microonde <i>Microwave frequency (Mhz)</i>	Programmi cottura <i>Cooking programs</i>
DECS 11M	230/50	1,0	330x330 h.197	2450	20





FORNO PER PIZZA INOX

S/STEEL PIZZA OVENS

• Macchinario per uso professionale • Struttura in acciaio inossidabile AISI 304 • Suolo forno in materiale refrattario • Resistenze corazzate • Timer al pannello di controllo • NO Illuminazione interna • Termostati per il controllo della temperatura • Isolamento in fibra ceramica • Termometro • Norme CE • Fabbriato in Italia

• Professional equipment • Structured in AISI 304 s/steel • Cooking base made from refractory material • Stiffened heating element • Timer panel control • NO Internal lighting • Thermostats for temperature control • Tiled fibre insulation • Thermometer • CE approved • Proudly Made in Italy



	Alimentazione Power supply (Volt/Hz)	Potenza Motor power (Kwatt/Hp)	Dimensioni interne Internal dimensions (mm)	Temperatura Temperature (°C)	Termostati Thermostats	Capienza pizza Pizza capacity)
B1 V	230/50	2,2	405x405 h.110	50-500	1	1
B1+1 V		4,4	405x405 h.110 x2		2	1+1
B7	230/50 230-400/50	4,0	500x510 h.110		2	1
B7+7		8,0	500x510 h.110 x2		4	1+1

B1 V PIZZA Ø40 CM



Peso netto
Net weight (kg)
26,0 kg



Dimensioni prodotto
Product dimension (mm)
B. 555 / D. 460 / H. 290



B1+1 V PIZZA Ø40 CM



Peso netto
Net weight (kg)
46,0 kg



Dimensioni prodotto
Product dimension (mm)
B. 555 / D. 460 / H. 580



B7 PIZZA Ø50 CM



Peso netto
Net weight (kg)
45,0 kg



Dimensioni prodotto
Product dimension (mm)
B. 715 / D. 570 / H. 310



B7+7 PIZZA Ø50 CM



Peso netto
Net weight (kg)
79,0 kg



Dimensioni prodotto
Product dimension (mm)
B. 715 / D. 570 / H. 550



NORME CE / CE APPROVED

	Trifase / Three phase V. 230/400	Monofase / Single phase V. 230
B1 V codice prodotto product code		B1 V
B1+1 V codice prodotto product code		B1+1 V
B7 codice prodotto product code	B7T	B7M
B7+7 codice prodotto product code	B7+7 T	B7+7 M
BP7SR optional piedistallo senza ruote optional stand codice prodotto product code	BP7SR	
BP7CR optional piedistallo con ruote optional wheels for oven stand codice prodotto product code	BP7CR	



FORNO PER PIZZA INOX

S/STEEL PIZZA OVENS

• Macchinario per uso professionale • Struttura in acciaio inossidabile AISI 304 • Sportello con vetro per alte temperature • Suolo forno in materiale refrattario • Resistenze corazzate • Timer al pannello di controllo • SI Illuminazione interna • Temperatura da 50°C a 500°C • Termostati per il controllo della temperatura • Isolamento in fibra ceramica • A richiesta piedistallo in acciaio inox • Termometro • Norme CE • Fabbricato in Italia

• Professional equipment • Structured in AISI 304 s/steel • Glass door for high temperature cooking • Cooking base made from refractory material • Stiffened heating element • Timer panel control • YES Internal lighting • Temperature ranging from 50°C up to 500°C • Thermostats for temperature control • Tiled fibre insulation • On demand: S/steel floor stand • Thermometer • CE approved • Proudly Made in Italy



	Alimentazione Power supply (Volt/Hz)	Potenza Motor power (Kwatt/Hp)	Dimensioni interne Internal dimensions (mm)	Temperatura Temperature (°C)	Termostati Thermostats	Capienza pizza Pizza capacity)
B8	230/50 230-400/50	6,0	720x720 h.140	50-500	2	4
B8+8		12,0	720x720 h.140 x2		4	4+4
B9		9,0	720x1080 h.140		2	6
B9+9		18,0	720x1080 h.140 x2		4	6+6

B8 PIZZA Ø36 CM



Peso netto
Net weight (kg)
95,0 kg



Dimensioni prodotto
Product dimension (mm)
B. 1010 / D. 850 / H. 420



B8+8 PIZZA Ø36 CM



Peso netto
Net weight (kg)
180,0 kg



Dimensioni prodotto
Product dimension (mm)
B. 1010 / D. 850 / H. 750



B9 PIZZA Ø36 CM



Peso netto
Net weight (kg)
137,0 kg



Dimensioni prodotto
Product dimension (mm)
B. 1010 / D. 1210 / H. 420



B9+9 PIZZA Ø36 CM



Peso netto
Net weight (kg)
232,0 kg



Dimensioni prodotto
Product dimension (mm)
B. 1010 / D. 1210 / H. 750



NORME CE / CE APPROVED

	Trifase / Three phase V. 230/400	Monofase / Single phase V. 230
B8 codice prodotto <i>product code</i>	B8T	B8M
BP8SR optional piedistallo <i>optional stand</i> codice prodotto <i>product code</i>	BP8SR	
BP8CR optional piedistallo con ruote <i>optional wheels for oven stand</i> codice prodotto <i>product code</i>	BP8CR	
B8+8 codice prodotto <i>product code</i>	B8+8T	B8+8M
BP8SR optional piedistallo <i>optional stand</i> codice prodotto <i>product code</i>	BP8SR	
BP8CR optional piedistallo con ruote <i>optional wheels for oven stand</i> codice prodotto <i>product code</i>	BP8CR	
B9 codice prodotto <i>product code</i>	B9T	B9M
BP9SR optional piedistallo <i>optional stand</i> codice prodotto <i>product code</i>	BP9SR	
BP9CR optional piedistallo con ruote <i>optional wheels for oven stand</i> codice prodotto <i>product code</i>	BP9CR	
B9+9 codice prodotto <i>product code</i>	B9+9T	B9+9M
BP9SR optional piedistallo <i>optional stand</i> codice prodotto <i>product code</i>	BP9SR	
BP9CR optional piedistallo con ruote <i>optional wheels for oven stand</i> codice prodotto <i>product code</i>	BP9CR	



SALAMANDRE SALAMANDER

• Macchinario per uso professionale • Struttura in acciaio inox • Tubi al quarzo che garantiscono un utilizzo immediato • Regolatore di potenza • Norme CE • Fabbriato in Italia

• Professional equipment • Stainless steel body • The model 40 has quartz tubes that guarantee an immediate use • The power regulator • CE approved • Proudly Made in Italy



	Alimentazione Power supply (Volt/Hz)	Potenza Motor power (Kwatt/Hp)	Altezza utile Useful height (mm)	Dimensione griglia Grill dimension (mm)
FS 40	230 / 50-60	2,2	90=170	410x350
FS 70		3,2	120=220	630x350
FS 60	230-400 - 50-60	4,0	100=260	500x300

FS40



Peso netto
Net weight (kg)
16,5 kg



Dimensioni prodotto
Product dimension (mm)
B. 560 / D. 360 / H. 390



FS70



Peso netto
Net weight (kg)
21,0 kg



Dimensioni prodotto
Product dimension (mm)
B. 760 / D. 360 / H. 470



FS60 Testa mobile



Peso netto
Net weight (kg)
44,0 kg



Dimensioni prodotto
Product dimension (mm)
B. 600 / D. 480 / H. 500



NORME CE / CE APPROVED

FS40 salamandra in acciaio inox *s/steel salamander*
codice prodotto *product code*

FS40

FS70 salamandra in acciaio inox *s/steel salamander*
codice prodotto *product code*

FS70

FS60 salamandra in acciaio inox testa mobile
s/steel adjustable heating salamander
codice prodotto *product code*

FS60



FORNETTI OVENS

• Macchinario per uso professionale • Struttura in acciaio inossidabile AISI 304 • Riscaldamento veloce • Pinze in acciaio • Griglie di cottura asportabili • Cassetto raccolta scarti • Timer di regolazione • Norme CE • Fabbricato in Italia

• Professional equipment • Structured in AISI 304 s/steel • Fast Heating • S/steel pliers • Removable Cooking grate • Breadcrumbs drawer • Timer control • CE approved • Proudly Made in Italy



	Alimentazione Power supply (Volt/Hz)	Potenza Motor power (Kwatt/Hp)	Numero pinze No. of pliers (mm)
Q4	230 / 50-60	1,2	2
Q5		1,9	3
Q12		2,8	6
Q18		2,8	9

Q4



Peso netto
Net weight (kg)
4,0 kg



Dimensioni prodotto
Product dimension (mm)
B. 320 / D. 230 / H. 220



Q6



Peso netto
Net weight (kg)
5,5 kg



Dimensioni prodotto
Product dimension (mm)
B. 430 / D. 230 / H. 230



Q12



Peso netto
Net weight (kg)
8,5 kg



Dimensioni prodotto
Product dimension (mm)
B. 430 / D. 230 / H. 350



Q18



Peso netto
Net weight (kg)
10,0 kg



Dimensioni prodotto
Product dimension (mm)
B. 430 / D. 230 / H. 350



NORME CE / CE APPROVED

Q4 fornetto in acciaio inox 2 pinze s/steel oven 2 racks
codice prodotto product code

Q4

Q6 fornetto in acciaio inox 3 pinze s/steel oven 3 racks
codice prodotto product code

Q6

Q12 fornetto in acciaio inox 6 pinze s/steel oven 6 racks
codice prodotto product code

Q12

Q18 fornetto in acciaio inox 9 pinze s/steel oven 9 racks
codice prodotto product code

Q18



TOSTAPANE BREAD TOASTER

• Macchinario per uso professionale • Solidità della struttura in acciaio inox inossidabile • Forni verticali indipendenti • Coperchio e basamento lucido • Robuste pinze in acciaio inox (14×14 cm) • Elementi riscaldanti a lunga durata con sistema autopulente • Manopola ergonomica soft-touch • Tensione v. 230/50-60hz • Norme CE • Fabbricato in Italia

• Professional equipment • Robust and durable stainless steel structure • Polished top and bottom • Stainless steel robust pliers for professional use (14×14 cm) • Independent vertical ovens • Long-life heating elements with self-cleaning system • Soft-touch ergonomic knob • Power 230V 50 & 60 Hz • CE approved • Proudly Made in Italy



	Alimentazione Power supply (Volt/Hz)	Potenza Motor power (Kwatt/Hp)	Numero pinze No. of pliers (mm)	Produzione oraria Production per hour	Uscita fette Bread slices chute	Lunghezza nastro Conveyor tape length (cm)
MTP 100	230 / 50-60	1,3	2	60 pz	-	-
MTP 101		2,4	4	120 pz	-	-
MRT 600		2,1	-	600 pz	Posteriore Back chute	25
MRT 700		2,1	-	700 pz	Anteriore Front chute	25

MTP 100

Tostapane a 2 pinze



Peso netto
Net weight (kg)
4,0 kg



Dimensioni prodotto
Product dimension (mm)
B. 180 / D. 300 / H. 300



MTP 101

Tostapane a 4 pinze



Peso netto
Net weight (kg)
9,0 kg



Dimensioni prodotto
Product dimension (mm)
B. 370 / D. 300 / H. 300



MRT 600

Tostapane rotativo



Peso netto
Net weight (kg)
8,0 kg



Dimensioni prodotto
Product dimension (mm)
B. 330 / D. 460 / H. 290



MRT 700

Tostapane rotativo



Peso netto
Net weight (kg)
15,5 kg



Dimensioni prodotto
Product dimension (mm)
B. 340 / D. 410 / H. 360



NORME CE / CE APPROVED

MTP100 tostapane verticale 2 pinze *vertical toaster 2 racks*
codice prodotto *product code*

MTP100

MTP101 tostapane verticale 4 pinze *vertical toaster 4 racks*
codice prodotto *product code*

MTP101

MRT600 tostapane rotativo medio *medium conveyon toaster*
codice prodotto *product code*

MRT600

MRT700 tostapane rotativo medio *medium conveyon toaster*
codice prodotto *product code*

MRT700



CREPIERA ELETTRICA COUNTER TOP CREPE GRIDDLE

• Macchinario ad uso professionale • Struttura in acciaio inox • Segnale luminoso di presenza tensione e funzionamento • Cavo di collegamento ignifugo • Piatto in ghisa • Distribuzione termica omogenea • Resistenze corazzate • Forma compatta • Poco ingombro • Norme CE • Fabbricato in Italia

• Professional equipment • Structured in s/steel • LED Panel control • Fire-proof cable • Cast iron cooking surface • Homogeneous heating • Stiffened heating element • Compact shape • Reduced overall dimensions • CE approved • Proudly Made in Italy



	Alimentazione Power supply (Volt/Hz)	Potenza Motor power (Kwatt/Hp)	Temperatura max Temperature max (°C)
CSP	230 / 50	2,4	300
CSP 40			
CPD	230/50 230-400/50	4,8	

CPS 35 - CPS 40



Diametro
Diametre (mm)
350



Diametro
Diametre (mm)
400



Peso netto
Net weight (kg)
13,0 kg



Peso netto
Net weight (kg)
18,0 kg



Dimensioni prodotto
Product dimension (mm)
B. 370 / D. 412 / H. 178



Dimensioni prodotto
Product dimension (mm)
B. 470 / D.420 / H. 178



CPD



Diametro
Diametre (mm)
350 x2



Peso netto
Net weight (kg)
25,0 kg



Dimensioni prodotto
Product dimension (mm)
B. 760 / D. 410 / H.178



NORME CE / CE APPROVED

CPS ø 350 mm

codice prodotto product code

CPS

CPS40 ø 400 mm

codice prodotto product code

CPS40

CPD ø 350 mm

codice prodotto product code

CPD



PIASTRE GHISA CAST IRON SINGLE GRILL

- Macchinario per uso professionale • Struttura in acciaio inox • Facile da maneggiare e da posizionare • Offre in poco spazio una ottimale superficie di lavoro • Disponibile con piastre sia lisce sia rigate • Piastra in ghisa con trattamento di vetroceramicatura • Massima robustezza e durata • Ottima conducibilità termica • Piastra superiore regolabile ad esigenza dell' operatore • Piastra superiore autobilanciata • Resistenze corazzate aderenti alle piastre • Manopole di regolazione soft-touch • Regolazione temperatura con termostato in acciaio inox fino 300°C • Resistenti a ruggine, acidi e sale • Estrema facilità di pulizia • Norme CE • Fabbricato in Italia

- Professional equipment • Thanks to its small size, it is easy to handle and to position, offering as well a large cooking surface • Structured in stainless steel • Ribbed and smooth surfaces available • Cast iron plates with ceramic coating treatment: highest sturdiness and life time, perfect thermal conductivity, very easy to clean. • Adjustable upper plates • Self balancing upper plate • Shock-proof coated heating elements, adherent to the plates for a perfect thermal conductivity • Soft-touch control handles • Rust and sour resistant • S/steel Thermostat for temperature setting up to 300° degree • Cleaning brush • CE approved • Proudly Made in Italy



	Alimentazione Power supply (Volt/Hz)	Potenza Motor power (Kwatt/Hp)	Piano utile inferiore Bottom plate dimensions (mm)	Temperatura max Temperature max (°C)
PSINGS	230 / 50-60	1,5	250x255	300
PSING		1,7	290x240	
PCORTS		2,1	355x255	
PCORT		2,8	430x230	
PDR 3000S		3,0	500x255	
PDR 3000		3,5	610x245	

PSINGS SINGOLA SINGLE



Peso netto
Net weight (kg)
16,0 kg



Dimensioni prodotto
Product dimension (mm)
B. 260 / D. 435 / H. 235



PSING SINGOLA SINGLE



Peso netto
Net weight (kg)
13,0 kg



Dimensioni prodotto
Product dimension (mm)
B. 310 / D. 380 / H. 170



PCORTS MEDIA MEDIUM



Peso netto
Net weight (kg)
22,0 kg



Dimensioni prodotto
Product dimension (mm)
B. 380 / D. 435 / H. 235



PCORT MEDIA MEDIUM



Peso netto
Net weight (kg)
19,0 kg



Dimensioni prodotto
Product dimension (mm)
B. 450 / D. 380 / H. 250



PDR 3000S DOPPIA DOUBLE



Peso netto
Net weight (kg)
28,0 kg



Dimensioni prodotto
Product dimension (mm)
B. 515 / D. 535 / H. 235



PDR 3000 DOPPIA DOUBLE



Peso netto
Net weight (kg)
28,0 kg



Dimensioni prodotto
Product dimension (mm)
B. 640 / D. 380 / H. 170



	NORME CE / CE APPROVED
PSINGS piastra singola in ghisa cast iron single grill codice prodotto product code	PSINGS
PCORTS piastra media in ghisa cast iron medium grill codice prodotto product code	PCORTS
PDR3000S piastra doppia in ghisa cast iron double grill codice prodotto product code	PDR3000S
PSING piastra singola in ghisa cast iron single grill codice prodotto product code	PSING
PCORT piastra media in ghisa cast iron medium grill codice prodotto product code	PCORT
PDR3000 piastra doppia in ghisa cast iron double grill codice prodotto product code	PDR3000

*** TUTTI I MODELLI SI POSSONO AVERE
CON LA PARTE INFERIORE LISCIA
ALL MODELS CAN BE HAVE WITH
THE BOTTOM SMOOTH**

SU RICHIESTA SENZA SUPPLEMENTO, IL MODELLO PDR3000 SI PUÒ
AVERE CON LA PARTE INFERIORE TUTTA LISCIA O MEZZA RIGATA E
MEZZA LISCIA ON REQUEST PDR3000 FLAT OR HALF FLAT/HALF RIBBED
BOTTOM GRILL WITHOUT ANY ADDITIONAL CHARGES



is hot after cooking, please don't touch with your hand.

Induction

2000

TIMER

+

-

POWER

TEMP

TIMER

POWER

TEMP

ON/OFF

FAMA
Industrie

PIASTRE INDUZIONE

INDUCTION GRILLS



- Macchinario per uso professionale • Struttura in acciaio inox • Timer con display a led (0-180 min) • Piano in vetro nera • Protezione elettronica per il surriscaldamento • Doppia ventola di raffreddamento • Facile da pulire • Norme CE
- Professional equipment • Stainless steel structure • Timer function 1-180 min • Black glass plate • Electronic protection for overheating • Double cooling fan • Easy to clean • CE approved • Proud

PIND 01 - PRESS TOUCH



Dimensioni prodotto
Product dimension (mm)
B. 340 / D. 440 / H. 115



PIND 02 - TOUCH CONTROL



Dimensioni prodotto
Product dimension (mm)
B. 340 / D. 390 / H. 95



PIND 02 - TOUCH CONTROL WOK



Dimensioni prodotto
Product dimension (mm)
B. 360 / D. 425 / H. 125



	Alimentazione Power supply (Volt/Hz)	Potenza Power input (Kwatt)	Piano utile inferiore Bottom plate dimensions (mm)	Temperatura Temperature (°C)	Peso netto Net weight (kg)
PIND 01	230/50•60	3,5	380x300	300	5,3
PIND 02			380x300		5,2
PIND 03			420x380		5,85

NORME CE / CE APPROVED

Monofase / Single phase V. 230

PIND01 Piano ad Induzione Press Touch / Induction Cooker Press Touch

codice prodotto product code

PIND01

PIND02 Piano ad Induzione Touch Control / Induction Cooker Touch Control

codice prodotto product code

PIND02

PIND03 Piano ad Induzione Wok Touch Control / Wok Induction Cooker Touch Control

codice prodotto product code

PIND03





PIASTRA VETROCERAMICA MEDIUM PYROCERAM GRILL

• Macchinario per uso professionale • Struttura in acciaio inox • Piano in vetroceramica di elevato spessore ad alta resistenza termica • Ampia superficie utile di lavoro • Piano superiore bilanciato e regolabile • Elevatissima velocità di riscaldamento (300° C in 3 min) • Regolazione della temperatura con termostato in acciaio inox fino a 300° C • Interruttore on/off con spia luminosa • Cassetto estraibile di raccolta grassi, lavabile in lavastoviglie • Raschietto di pulizia • Basso consumo energetico grazie all'efficiente sistema riscaldante e all'ottimo isolamento • Manopola ergonomica soft-touch • Facile da pulire • Norme CE • Fabbricato in Italia

• Professional equipment • Stainless steel structure • Thick glass ceramic plate for a higher heating resistance • Large working surface • Balanced upper plate with adjustable closing pressure • Ultra high heating speed (300° C in 3 minutes and a half) • Stainless steel thermostat to adjust the temperature up to max 300°C • On/off switch with orange indicator light • Removable crumb/drip tray washable in dishwasher • Low Energy consumption thanks to the heating and insulation system • Soft-touch ergonomic knob • Easy to clean • CE approved • Proudly Made in Italy



	Alimentazione Power supply (Volt/Hz)	Potenza Motor power (Kwatt/Hp)	Piano utile inferiore Bottom plate dimensions (mm)	Temperatura max Temperature max (°C)
UPM	230 / 50-60	2,1	360x280	300
UPD		3,2	590x280	

UPM SINGOLA SINGLE



Peso netto
Net weight (kg)
13,0 kg



Dimensioni prodotto
Product dimension (mm)
B. 410 / D. 480 / H. 210

* Di serie parte superiore rigata, parte inferiore liscia



UPD DOPPIA DOUBLE



Peso netto
Net weight (kg)
21,5 kg



Dimensioni prodotto
Product dimension (mm)
B. 640 / D. 480 / H. 210

* Di serie parte superiore rigata, parte inferiore liscia



NORME CE / CE APPROVED

UPM piastra media in vetroceramica *medium pyroceram grill*
codice prodotto *product code*

UPM

UPD piastra doppia in vetroceramica *double glass pyroceram grill*
codice prodotto *product code*

UPD



FRY-TOP ACCIAIO STEEL FRY-TOP

- Macchinario per uso professionale • Struttura in acciaio inossidabile • Cassetto estraibile per la raccolta dei grassi e liquidi di cottura • Nuova manopola ergonomica soft-touch • Elevata velocità di riscaldamento • Riscaldamento uniforme della superficie di lavoro • Potenza regolabile con regolatore di energia interruttore e lampada spia • Paraspruzzi su 3 lati • Norme CE • Fabbriato in Italia

- Professional equipment • Structured in stainless steel • Scraper included for easy cleaning of the plate removable grease/crumb tray • New soft-touch ergonomic knob • Ultra high heating speed • Uniform heating of the plate • Power regulator switch and pilot lamp • Splash guards on 3 sides • Pyroceram grills are low energy input models • CE approved • Proudly Made in Italy



	Alimentazione Power supply (Volt/Hz)	Potenza Motor power (Kwatt/Hp)	Piano utile inferiore Bottom plate dimensions (mm)	Temperatura max Temperature max (°C)
PFT 1L	230 / 50-60	3,0	395x400	300
PFT 2L		6,0	595x400	
PFT 3L		9,0	835x400	

PFT 1L



Peso netto
Net weight (kg)
20,5 kg



Dimensioni prodotto
Product dimension (mm)
B. 400 / D. 500 / H. 200



PFT 2L



Peso netto
Net weight (kg)
28,0 kg



Dimensioni prodotto
Product dimension (mm)
B. 600 / D. 500 / H. 200



PFT 3L



Peso netto
Net weight (kg)
34,5 kg



Dimensioni prodotto
Product dimension (mm)
B. 900 / D. 600 / H. 410



NORME CE / CE APPROVED

PFT 1L fry top acciaio piccola *small steel fry top*

codice prodotto *product code*

PFT1L

PFT 2L fry top acciaio media *medium steel fry top*

codice prodotto *product code*

PFT2L

PFT 3L fry top acciaio maxi *maxi steel fry top*

codice prodotto *product code*

PFT3L



FRY-TOP VETROCERAMICA PYROCERAM FRY-TOP

- Macchinario per uso professionale • Struttura in acciaio inossidabile • Piani in vetroceramica lisci di grande spessore • Cassetto estraibile per la raccolta dei grassi e liquidi di cottura • Varie dimensioni di piano di lavoro • Nuova manopola ergonomica soft-touch • Elevata velocità di riscaldamento • Riscaldamento uniforme della superficie di lavoro • Potenza regolabile con regolatore di energia interruttore e lampada spia • Facilità di pulizia del piano in vetroceramica con apposito raschietto • Paraspruzzi su 3 lati • Basso consumo di energia • Norme CE • Fabbriato in Italia

- Professional equipment • Structured in stainless steel • Smooth, extra thick glass ceramic plate • Scraper included for easy cleaning of the plate removable grease/crumb tray • Wide range of cooking surfaces • New soft-touch ergonomic knob • Ultra high heating speed • Uniform heating of the plate • Power regulator switch and pilot lamp • Scraper included for easy cleaning of the plate • Splash guards on 3 sides • Pyroceram grills are low energy input models • CE approved • Proudly Made in Italy



	Alimentazione Power supply (Volt/Hz)	Potenza Motor power (Kwatt/Hp)	Piano utile inferiore Bottom plate dimensions (mm)	Temperatura max Temperature max (°C)
PFTM	230 / 50-60	1,1	360x280	350
PFTD		3,0	510x550	

PFTM



Peso netto
Net weight (kg)
7,5 kg



Dimensioni prodotto
Product dimension (mm)
B. 360 / D. 340 / H. 150



PFTD



Peso netto
Net weight (kg)
16,0 kg



Dimensioni prodotto
Product dimension (mm)
B. 520 / D. 580 / H. 160



NORME CE / CE APPROVED

PFTM fry top in vetroceramica media *medium pyroceram fry top*
codice prodotto *product code*

PFTM

PFTD fry top in vetroceramica maxi *maxi pyroceram fry top*
codice prodotto *product code*

PFTD



REFRIGERAZIONE
refrigeration



PROFESSIONISTI
ANCHE NELLA REFRIGERAZIONE

PROFESSIONALS
ALSO IN REFRIGERATION

ABBATTITORI DIGITALI
DIGITAL BLAST CHILLERS

ABBATTITORI TOUCH
DIGITAL TOUCH BLAST CHILLERS

ARMADI REFRIGERATI VENTILATI
VENTILATED REFRIGERATED CABINETS

TAVOLI REFRIGERATI VENTILATI
VENTILATED REFRIGERATED TABLES





ABBATTITORE DIGITALE

DIGITAL BLAST CHILLER



- Apparecchio per uso professionale • Interno ed esterno in acciaio inossidabile, con esclusione del fondo esterno in Acciaio Galvanizzato • Angoli interni arrotondati • Isolamento in poliuretano senza CFC, iniettato ad alta pressione • Spessore dell'isolamento 60 mm • Porta con chiusura automatica e guarnizione magnetica • Dotato di sonda al cuore • Pannello frontale con scheda di controllo elettronica con sonda camera e sonda spillone al cuore (versione digitale) • Pannello di controllo touch con display digitale (programmi di abbattimento positivo e negativo, temperatura di abbattimento, temperatura al cuore, tempi di abbattimento, conservazione) (versione digitale touch) • Refrigerazione ventilata con agitatore d'aria • Unità refrigerante facilmente estraibile e tropicalizzata di serie (temperatura ambiente +43°C ed umidità relativa del 65%) • Sbrinamento evaporatore a tempo, a fine ciclo, e vaschetta inferiore di contenimento acqua di condensa • Adatto a contenere 3 teglie GN 1/1 o 600x400 mm • Teglie non incluse • Norme CE • Fabbriato in Italia

- Professional equipment • Inside and outside made of Stainless Steel, except for the external bottom made of Galvanized Steel • Internal rounded corners • Insulation in CFC free polyurethane high pressure injected • Insulation thickness 60 mm • Self-closing door with magnetic gaskets • The core probe is included • Electronic front control panel with room probe and temperature core probe (digital model) • Capacitive touch digital control panel with digital display (positive blast chilling, negative shock freezing, blast chilling temperature, core probe temperature, blast chilling time, conservation) (digital touch model) • Ventilated cooling with air shaker • Tropicalized and easy extractable condensing unit (ambient temperature +43°C and relative humidity of 65%) • Time evaporator defrosting (made at the end of the cycle) and lower condense water tray • Suitable for 3 trays GN 1/1 or 600x400 mm • Trays not included • CE approved • Proudly Made in Italy



Per modelli fabb 3 - fabb 4 - fabb 5 disponibile versione touch display
For model fabb 3 - fabb 4 - fabb 5 touch display model available

	Alimentazione Power supply (Volt/Hz)	Assorbimento Power input (Watt)	Temperatura Chamber Temperature (°C)	Tipo refrigerante Refrigerant	Dimensioni camera Chamber dimensions (mm)	Capacità Capacity	Spazio tra teglie Space between trays (mm)	Resa abbattimento Blast chilling performance (+3°C)	Resa surgelazione Blast freezing performance (-18°C)
FABB 2/3	230/50	520	+3 / -40	R452a / R507a	340x363x270	3 - GN 2/3	80	9,0 kg	7,0 kg
FABB 3		1150			610x410x280	3 - GN 1/1 3 - 600x400			
FABB 5		1424			610x410x410	5 - GN 1/1 5 - 600x400	70	23,0 kg	12,0 kg
FABB 10		1490			610x410x760	10 - GN 1/1 10 - 600x400			

FABB 23
2/3 - 3 TEGLIE
2/3 - 3 TRAYS



Peso netto
Net weight (kg)
45,0 kg



Dimensioni prodotto
Product dimension (mm)
B. 658 / D. 630 / H. 420



FABB 3
3 TEGLIE
3 TRAYS



Peso netto
Net weight (kg)
82,0 kg



Dimensioni prodotto
Product dimension (mm)
B. 750 / D. 740 / H. 750



FABB 5
5 TEGLIE
5 TRAYS



Peso netto
Net weight (kg)
92,0 kg



Dimensioni prodotto
Product dimension (mm)
B. 750 / D. 740 / H. 870



FABB 10
10 TEGLIE
10 TRAYS



Peso netto
Net weight (kg)
112,0 kg



Dimensioni prodotto
Product dimension (mm)
B. 750 / D. 740 / H. 1300



	NORME CE / CE APPROVED
FABB23 abbattitore digitale <i>digital blast chiller</i> codice prodotto <i>product code</i>	FABB23
FFR23 optional teglia GN 2/3 <i>optional tray GN 2/3</i> codice prodotto <i>product code</i>	FFR23
FABB3 abbattitore digitale <i>digital blast chiller</i> codice prodotto <i>product code</i>	FABB3
FABB3 abbattitore digitale touch <i>digital touch blast chiller</i> codice prodotto <i>product code</i>	FABB3
FABB5 abbattitore digitale <i>digital blast chiller</i> codice prodotto <i>product code</i>	FABB5
FABB5 abbattitore digitale touch <i>digital touch blast chiller</i> codice prodotto <i>product code</i>	FABB5
FABB10 abbattitore digitale <i>digital blast chiller</i> codice prodotto <i>product code</i>	FABB10
FABB10 abbattitore digitale touch <i>digital touch blast chiller</i> codice prodotto <i>product code</i>	FABB10
FFR108 optional teglia GN 1/1 <i>optional tray GN 1/1</i> codice prodotto <i>product code</i>	FFR108
FFR104 optional teglia 600x400 mm <i>optional tray 600x400 mm</i> codice prodotto <i>product code</i>	FFR104

CARATTERISTICHE ABBATTITORI

BLAST CHILLERS FEATURES



SONDA AL CUORE
CORE PROBE



DISPLAY DIGITALE
DIGITAL DISPLAY



DISPLAY TOUCH
TOUCH DISPLAY



INTERNO ED ESTERNO
IN ACCIAIO INOX
*INSIDE AND OUTSIDE MADE
OF STAINLESS STEEL*



REFRIGERAZIONE VENTILATA
CON AGITATORE D'ARIA
VENTILATED COOLING WITH AIR SHAKER





Ogni alimento, una volta cucinato, perde rapidamente le sue caratteristiche di sapore, nutrizionali e organolettiche. Una pietanza calda (+70° / +10°) è rapidamente aggredita dalla deteriorazione e dai batteri. Solamente un raffreddamento rapido del prodotto consente di mantenerne le caratteristiche iniziali, proteggendolo dall'aggressione dei germi. Un abbattimento rapido del prodotto permette di preservare la freschezza, il sapore e le condizioni organolettiche delle pietanze.

Tale operazione consente di conservare cibi sani e più a lungo. Per conservare un prodotto alimentare a medio-lungo termine mantenendone inalterate le caratteristiche nutrizionali, non vi è altra soluzione che surgelarlo fino ad una temperatura di -18° al cuore nel più breve tempo possibile tramite l'utilizzo dell'abbattitore. Al momento dello scongelamento d'ogni materia prima, semilavorato o cibo cotto non si avranno perdite di liquidi, sapore e consistenza e si potrà procedere alla normale preparazione di pietanze dalle elevate proprietà nutrizionali e qualitative.

VANTAGGI DELL'USO

- Ottimizzazione dei tempi in cucina
- Razionalizzazione dei tempi di lavoro
- Riduzione del calo di peso per porzione
- Menù più ricco
- Riduzione del costo degli approvvigionamenti e delle materie prime
- Niente più sprechi e riduzione degli scarti
- Mantenimento dei valori organolettici degli alimenti
- Maggiore tutela alimentare

Each food, once cooked, can quickly lose its flavor, as the nutritional and organoleptic characteristics. Moreover, a hot dish (70° / 10°) is quickly attacked by deterioration and bacteria. Only a rapid cooling of the product allows to maintain its initial characteristics, by protecting it from the aggression of germs. The "core" chilling until a temperature of 3° can help to pass over this critical threshold in the shortest time possible time, maintaining the freshness, the flavor and the organoleptic characteristics of the dishes.

This operation allows to keep the healthy food longer. To preserve the food for a medium- long period and to maintain its nutritional value, there is no other solution but to freeze it until core temperature of -18° in less as soon as possible. Upon the thawing of each raw material or semi-cooked foods, there will not be losing of fluids, flavor and texture and it will be possible to proceed with the normal preparation of the meals with high nutritional and qualitative values.

THE ADVANTAGE OF USING

- Kitchen time optimization
- Labour time rationalization
- Loss of weight reduction per portion
- Larger menu
- Raw materials and provisioning cost reduction
- No more waste and scrap reduction
- Maintenance of the organoleptic values of food
- More alimentary protection



ARMADIO REFRIGERATO VENTILATO

REFRIGERATED VENTILATED CABINET



- Apparecchio per uso professionale • TN temperatura normale (0°+10°)
- Interno ed esterno in acciaio inossidabile, eccetto fondo, soffitto e schienale esterni in acciaio galvanizzato • Isolamento in poliuretano senza CFC, iniettato ad alta pressione • Spessore dell'isolamento: 60 mm • Refrigerazione ventilata • Unità refrigerante a monoblocco estraibile e tropicalizzata di serie (temperatura ambiente +40°C ed umidità relativa del 60%) • Sbrinamento ed evaporazione dell'acqua di condensa completamente automatici • Porte a chiusura automatica con guarnizione magnetica, ed impugnatura ergonomica, facilmente apribile • Pannello di controllo elettronico frontale con sonda NTC • Angoli interni arrotondati • Piedi in acciaio inossidabile regolabili in altezza (110/190 H mm) • Fermoventola di serie • Versione Luxury (resistenza di sbrinamento automatica di serie, luce interna di serie LED a basso consumo, serratura di serie) • 3 griglie GN 2/1 e 3 kit ganci di serie • Norme CE • Fabbricato in Italia

- Professional equipment • TN normal temperature (0°+10°) • Inside and outside made of stainless steel, except for external bottom, external ceiling and back made of galvanized steel • Insulation in CFC free polyurethane high pressure injected • Insulation thickness: 60 mm • Ventilated cooling • Tropicalized and extractable "monoblock type" condensing unit (ambient temperature +40°C and relative humidity of 60%) • Complete automatic defrosting and condensing water evaporation • Automatic closing doors with magnetic seal, and ergonomic handle, easy to open • Electronic front control panel with NTC probe • Internal rounded corners • Adjustable Stainless Steel feet (110/190 H mm) • Standard fan brake • Luxury model (automatic defrosting resistance as standard, internal lighting standard - low consumption led lighting, lock standard) • Inclusive of GN 2/1 and hook kit (3 pcs.) • CE approved • Proudly Made in Italy

	Alimentazione Power supply (Volt/Hz)	Assorbimento Power input (Watt)	Temperatura Temperature (°C)	Tipo refrigerante Refrigerant	Collaudo Temperatura/ Umidità Temperature/Humidity test (°C/HR)	Capacità Capacity
FFR 700TN	230/50	385	0 / +10	R452a	+40 / 60%	700
FFR 700BT		650	-18 / -22			
FFR 1400TN		570	0 / +10			1400
FFR 1400BT		700	-18 / -22			

FFR 700TN



Peso netto
Net weight (kg)
110,0 kg



Dimensioni prodotto
Product dimension (mm)
B. 710 / D. 800 / H. 2100



FFR 700BT



Peso netto
Net weight (kg)
120,0 kg



Dimensioni prodotto
Product dimension (mm)
B. 710 / D. 800 / H. 2100



FFR 1400TN



Peso netto
Net weight (kg)
150,0 kg



Dimensioni prodotto
Product dimension (mm)
B. 1420 / D. 800 / H. 2100



FFR 1400BT



Peso netto
Net weight (kg)
160,0 kg



Dimensioni prodotto
Product dimension (mm)
B. 1420 / D. 800 / H. 2100



	NORME CE / CE APPROVED
FFR700TN armadio refrigerato refrigerated cabinet codice prodotto product code	FFR700TN
FFRL700TN armadio refrigerato luxury luxury refrigerated cabinet codice prodotto product code	FFRL700TN
FFR700BT armadio refrigerato refrigerated cabinet codice prodotto product code	FFR700BT
FFRL700BT armadio refrigerato luxury luxury refrigerated cabinet codice prodotto product code	FFRL700BT
FFR1400TN armadio refrigerato refrigerated cabinet codice prodotto product code	FFR1400TN
FFRL1400TN armadio refrigerato luxury luxury refrigerated cabinet codice prodotto product code	FFRL1400TN
FFR1400BT armadio refrigerato refrigerated cabinet codice prodotto product code	FFR1400BT
FFRL1400BT armadio refrigerato luxury luxury refrigerated cabinet codice prodotto product code	FFRL1400BT
FFR100 optional griglia GN 2/1 plastificata optional GN 2/1 plastificated grill codice prodotto product code	FFR100
FFR109 optional griglia GN 2/1 acciaio inox optional GN 2/1 stainless steel grill codice prodotto product code	FFR109
FFR200 optional kit ganci optional hook kit codice prodotto product code	FFR200

CARATTERISTICHE ARMADI REFRIGERATI VENTILATI

REFRIGERATED VENTILATED CABINET FEATURES



PIEDI ACCIAIO INOX REGOLABILI IN ALTEZZA (110/190 H MM)
ADJUSTABLE STAINLESS STEEL FEET



ANGOLI INTERNI ARROTONDATI
INTERNAL ROUNDED CORNERS



PORTE A CHIUSURA AUTOMATICA CON GUARNIZIONE MAGNETICA ED IMPUGNATURA ERGONOMICA
AUTOMATIC CLOSING DOORS WITH MAGNETIC SEAL AND ERGONOMIC HANDLE



DISPLAY DIGITALE
DIGITAL DISPLAY



ILLUMINAZIONE INTERNA (SOLO VERSIONE LUXURY)
INTERNAL LIGHT (ONLY LUXURY MODEL)



CHIUSURA CON CHIAVE (SOLO VERSIONE LUXURY)
LOCK WITH KEY (ONLY LUXURY MODEL)



REFRIGERAZIONE VENTILATA
VENTILATED COOLING







TAVOLO REFRIGERATO VENTILATO

VENTILATED REFRIGERATED TABLE

- Apparecchio per uso professionale • Mobile refrigerato per griglie e contenitori GN 1/1 profondità 700 mm • Di serie 1 griglia e 1 coppia di guide • TN temperatura normale (-2° +8°) • Interno ed esterno in Acciaio Inossidabile, con esclusione del fondo esterno in Acciaio Galvanizzato • Angoli interni arrotondati • Isolamento in poliuretano senza CFC, iniettato ad alta pressione • Spessore dell'isolamento tavoli TN: 40 mm • Porte con chiusura automatica e guarnizione magnetica • Pannello di controllo elettronico frontale con sonda NTC • Refrigerazione ventilata • Unità refrigerante a monoblocco estraibile e tropicalizzata di serie (temperatura ambiente +40°C ed umidità relativa del 60%) • Sbrinatorio ed evaporazione dell'acqua di condensa completamente automatici • Piedi in Acciaio Inossidabile regolabili in altezza (110/190 H mm) • Disponibile con alzatina • Norme CE • Fabbriato in Italia

- Professional equipment • Refrigerated Pizza Counter 700 mm depth, for plasticized shelves and containers GN 1/1 • 1 tray and 1 pair of guides included • TN normal temperature (-2° +8°) • Inside and outside made of Stainless Steel, except for the external bottom made of Galvanized Steel • Internal rounded corners • Insulation in CFC free polyurethane high pressure injected • Insulation thickness NT counters: 40 mm • Self-closing doors with magnetic gaskets • Electronic front control panel with NTC probe • Ventilated cooling • Tropicalized and extractable "monoblock type" condensing unit (ambient temperature +40°C and relative humidity of 60%) • Complete automatic defrosting and condensing water evaporation • Adjustable Stainless Steel feet (110/190 H mm) • Backsplash on request • CE approved • Proudly Made in Italy



	Alimentazione Power supply (Volt/Hz)	Assorbimento Power input (Watt)	Temperatura Temperature (°C)	Tipo refrigerante Refrigerant	Collaudo Temperatura/ Umidità Temperature/Humidity test (°C/HR)	Capacità Capacity
FTR 2TN	230/50	495	0 / +10	R452a / R507	+40 / 60%	310
FTR 3TN						460
FTR 4TN						620

FTR 2TN

2 PORTE
2 DOORS



Peso netto
Net weight (kg)
86,0 kg



Dimensioni prodotto
Product dimension (mm)
B. 1420 / D. 700 / H. 850

Dimensioni prodotto con alzata
Product dimension with bacsplash (mm)
B. 1420 / D. 700 / H. 920



FTR 3TN

3 PORTE
3 DOORS



Peso netto
Net weight (kg)
102,0 kg



Dimensioni prodotto
Product dimension (mm)
B. 1870 / D. 700 / H. 850

Dimensioni prodotto con alzata
Product dimension with bacsplash (mm)
B. 1870 / D. 700 / H. 920



FTR 4TN

4 PORTE
4 DOORS



Peso netto
Net weight (kg)
118,0 kg



Dimensioni prodotto
Product dimension (mm)
B. 2320 / D. 700 / H. 850

Dimensioni prodotto con alzata
Product dimension with bacsplash (mm)
B. 2320 / D. 700 / H. 920



NORME CE / CE APPROVED

FTR2TN tavolo refrigerato *refrigerated table*

codice prodotto *product code*

FTR2TN

FTRA2TN tavolo refrigerato con alzata
refrigerated table with bacsplash

codice prodotto *product code*

FTRA2TN

FTR3TN tavolo refrigerato *refrigerated table*

codice prodotto *product code*

FTR3TN

FTRA3TN tavolo refrigerato con alzata
refrigerated table with bacsplash

codice prodotto *product code*

FTRA3TN

FTR4TN tavolo refrigerato *refrigerated table*

codice prodotto *product code*

FTR4TN

FTRA4TN tavolo refrigerato con alzata
refrigerated table with bacsplash

codice prodotto *product code*

FTRA4TN

FFR110 optional griglia plastificata *optional plastificated grill*

codice prodotto *product code*

FFR110

FFR111 coppia di guide *pair of guides*

codice prodotto *product code*

FFR111

CARATTERISTICHE TAVOLI REFRIGERATI VENTILATI

VENTILATED REFRIGERATED TABLE FEATURES



PIANO SUPERIORE LISCIO
SMOOTH UPPER FLOOR



ALZATINA SU RICHIESTA
BACKSPLASH ON REQUEST



PIEDI ACCIAIO INOX REGOLABILI IN
ALTEZZA (110/190 H MM)
ADJUSTABLE STAINLESS STEEL FEET



ANGOLI INTERNI ARROTONDATI
INTERNAL ROUNDED CORNERS



PANNELLO DI CONTROLLO
ELETTRONICO FRONTALE
ELECTRONIC FRONT CONTROL PANEL

BANCHI REFRIGERATI VENTILATI

VENTILATED REFRIGERATED COUNTERS



• Macchinario per uso professionale • Struttura interna ed esterna realizzata interamente in acciaio inox • Pannello posteriore in acciaio inox • Refrigerazione ventilata con evaporatore ad alette trattato anticorrosione • Termostato digitale per il controllo della temperatura e dello sbrinamento • Ricircolo aria fredda • Gruppo incorporato • Resistenza elettrica inserita nella cornice della porta per l'eliminazione della condensa • Evaporazione automatica dell'acqua di condensa • Spessore isolamento 60mm • Guarnizione magnetica facilmente estraibile • Interno con angoli arrotondati per facilitare la pulizia • Chiusura pannello frontale con chiave • Piedini in acciaio inox regolabili • Dotazione standard 1 griglia GN 1/1, 1 coppia di guida (per porta) • Norme CE

• Professional equipment • Internal and external structure entirely made of stainless steel • Back panel in stainless steel • Ventilated refrigeration with anticorrosion treated evaporator • Digital thermostat for temperature control and defrosting • Cold air recirculation • Incorporated refrigeration unit • Electrical heating element around door frame to eliminate condensation • Automatic condensation evaporation • 60mm insulation thickness • Easily removable magnetic gasket • Internal rounded edges for easy cleaning • Front panel with keylock • Adjustable stainless steel feet • Inclusive of 1 pcs GN 1/1 shelf and guide (for door) • CE approved

FBR2100TN



Dimensioni prodotto
Product dimension (mm)
B. 1360 / D. 700 / H. 860



FBR3100TN



Dimensioni prodotto
Product dimension (mm)
B. 1795 / D. 700 / H. 860



	Alimentazione Power supply (Volt/Hz)	Assorbimento Power input (Watt)	Temperatura Temperature (°C)	Tipo refrigerante Refrigerant	Peso netto Net weight (kg)	Collaudo Temperatura/ Umidità Temperature/Humidity test (°C/HR)	Capacità Capacity
FBR 2100 TN	230/50	300	-2 / +8	R134A	98	+43 / 60%	282
FBR 3100 TN					134		417

NORME CE / CE APPROVED

Monofase / Single phase V. 230

FBR2100TN 0,3 Kw (0,4 Hp)

codice prodotto product code

FBR2100TN

FBR3100TN 0,3 Kw (0,4 Hp)

codice prodotto product code

FBR3100TN



BANCHI PIZZA REFRI GERATI VENTILATI

VENTILATED REFRIGERATED COUNTERS PIZZA



- Macchinario per uso professionale • Struttura interna ed esterna realizzata interamente in acciaio inox • Top in granito • Refrigerazione ventilata con evaporatore ad alette trattato anticorrosione • Ricircolo aria fredda • Gruppo incorporato estraibile • Termostato digitale per il controllo della temperatura e dello sbrinamento • Resistenza elettrica inserita nella cornice della porta per l'eliminazione della condensa • Evaporazione automatica dell'acqua di condensa • Spessore isolamento 60mm • Guarnizione magnetica facilmente estraibile • Interno con angoli arrotondati per facilitare la pulizia • Chiusura pannello frontale con chiave • Piedini in acciaio inox regolabili • Pannello posteriore in acciaio inox • Dotazione standard 1 griglia 600x400 mm, 1 coppia di guida (per porta) • Norme CE

- Professional equipment • Internal and external structure entirely made of stainless steel • Granite worktop • Ventilated refrigeration with anticorrosion treated evaporator • Cold air recirculation • Incorporated refrigeration unit • Digital thermostat for temperature control and defrosting • Electrical heating element around door frame to eliminate condensation • Automatic condensation evaporation • 60mm insulation thickness • Easily removable magnetic gasket • Internal rounded edges for easy cleaning • Front panel with keylock • Adjustable stainless steel feet • Back panel in stainless steel • Inclusive of 1 pcs 600x400 shelf and guide (for door) • CE approved



FV15033

Dimensioni prodotto
Product dimension (mm)
B. 1500
D. 335
H. 435



FV20033

Dimensioni prodotto
Product dimension (mm)
B. 2000
D. 335
H. 435

FBR2610TN

Dimensioni prodotto
Product dimension (mm)
B. 2025
D. 800
H. 1000



FBR2600TN

Dimensioni prodotto
Product dimension (mm)
B. 1510
D. 800
H. 1000



FV20033

Dimensioni prodotto
Product dimension (mm)
B. 2000
D. 335
H. 435

FBR3600TN

Dimensioni prodotto
Product dimension (mm)
B. 2025
D. 800
H. 1000

	Alimentazione Power supply (Volt/Hz)	Assorbimento Power input (Kwatt)	Temperatura Temperature (°C)	Tipo refrigerante Refrigerant	Peso netto Net weight (kg)	Collaudo Temperatura/ Umidità Temperature/Humidity test (°C/HR)	Capacità Capacity
FBR2600TN	230/50	0,3	-2 / +8	R134a	260,0	+43 / 60	390
FV15033		0,15			58,0	+33 / 60	-
FBR2610TN		0,3			312,0	+43 / 60	390
FV20033		0,15			70,0	+33 / 60	-
FBR3600TN		0,3			312,0	+43 / 60	580
FV20033		0,15			70,0	+33 / 60	-

NORME CE / CE APPROVED
Monofase / Single phase V. 230

FBR2600TN 0,3 Kw codice prodotto product code	FBR2600TN
FBR2610TN 0,3 Kw codice prodotto product code	FBR2610TN
FBR3600TN 0,35 Kw codice prodotto product code	FBR3600TN
FV15033 0,15 Kw codice prodotto product code	FV15033
FV20033 0,13 Kw codice prodotto product code	FV20033



VETRINETTE REFRIGERATE PER PIZZERIA

REFRIGERATED PIZZA DISPLAY



• Macchinario per uso professionale • Struttura interna ed esterna realizzata interamente in acciaio inox • Refrigerazione statica • Gruppo incorporato • Termostato digitale per il controllo della temperatura • Spessore isolamento 40mm • Vetri di protezione inclusi • Idonee a contenere bacinelle gastronorm inox o in policarbonato con profondità massima di 150mm (bacinelle e coperchi esclusi) FV12033 5 x GN1/4 / FV15033 7 x GN1/4 / FV18033 9 x GN1/4 / FV20033 10 X GN1/4 • Norme CE

• Professional equipment • Internal and external structure entirely made of stainless steel • Static refrigeration • Built-in refrigeration unit • Digital temperature control thermostat • Insulation thickness 40mm • Protection glass included • Suited for Gastronorm stainless steel or polycarbonate pans with a max depth of 150mm (pans and covers not included) FV12033 5 x GN1/4 / FV15033 7 x GN1/4 / FV18033 9 x GN1/4 / FV20033 10 X GN1/4 • CE approved

FV12033



Dimensioni prodotto
Product dimension (mm)
B. 1200 / D. 335 / H. 435



FV15033



Dimensioni prodotto
Product dimension (mm)
B. 1500 / D. 335 / H. 435



FV18033



Dimensioni prodotto
Product dimension (mm)
B. 1800 / D. 335 / H. 435



FV20033



Dimensioni prodotto
Product dimension (mm)
B. 2000 / D. 335 / H. 435

	Alimentazione Power supply (Volt/Hz)	Assorbimento Power input (Kwatt)	Temperatura Temperature (°C)	Tipo refrigerante Refrigerant	Peso netto Net weight (kg)	Collaudo Temperatura/ Umidità Temperature/Humidity test (°C/HR)
FV12033	230/50	0,15	+2 / +8	R134a	50,0	+33 / 60%
FV15033					58,0	
FV18033					65,0	
FV20033					70,0	

NORME CE / CE APPROVED

Monofase / Single phase V. 230

FV12033 0,15 Kw
codice prodotto product code

FV12033

FV15033 0,15 Kw
codice prodotto product code

FV15033

FV18033 0,15 Kw
codice prodotto product code

FV18033

FV20033 0,15 Kw
codice prodotto product code

FV20033



- Attrezzatura per uso professionale • Corpo in acciaio inossidabile • Top in inox AISI 304 • Piedini regolabili • Ripiano inferiore incluso • Norme CE
- Professional equipment • Stainless steel material body • Top in inox AISI 304 • Adjustable feet • Lower shelf included • CE approved



FBL107



Dimensioni prodotto
Product dimension (mm)
B. 1000 / D. 700 / H. 850

FBL127



Dimensioni prodotto
Product dimension (mm)
B. 1200 / D. 700 / H. 850

FBL147



Dimensioni prodotto
Product dimension (mm)
B. 1400 / D. 700 / H. 850

FBL157



Dimensioni prodotto
Product dimension (mm)
B. 1500 / D. 700 / H. 850

FBL167



Dimensioni prodotto
Product dimension (mm)
B. 1600 / D. 700 / H. 850

FBL187



Dimensioni prodotto
Product dimension (mm)
B. 1800 / D. 700 / H. 850

FBL207



Dimensioni prodotto
Product dimension (mm)
B. 2000 / D. 700 / H. 850

FBL107

codice prodotto product code

FBL127

codice prodotto product code

FBL147

codice prodotto product code

FBL157

codice prodotto product code

FBL167

codice prodotto product code

FBL187

codice prodotto product code

FBL207

codice prodotto product code

NORME CE / CE APPROVED

FBL107

FBL127

FBL147

FBL157

FBL167

FBL187

FBL207

Peso netto
Net weight (kg)

FBL107

24,0

FBL127

29,0

FBL147

33,0

FBL157

34,0

FBL167

36,0

FBL187

38,0

FBL207

42,0

BANCHI DA LAVORO CON ALZATINA

WORK TABLES WITH RAISED BACK



- Attrezzatura per uso professionale • Corpo in acciaio inossidabile • Top in inox AISI 304 • Piedini regolabili • Ripiano inferiore incluso • Norme CE
- Professional equipment • Stainless steel material body • Top in inox AISI 304 • Adjustable feet • Lower shelf included • CE approved



FBL107A



Dimensioni prodotto
Product dimension (mm)
B. 1000 / D. 700 / H. 950

FBL127A



Dimensioni prodotto
Product dimension (mm)
B. 1200 / D. 700 / H. 950

FBL147A



Dimensioni prodotto
Product dimension (mm)
B. 1400 / D. 700 / H. 950

FBL157A



Dimensioni prodotto
Product dimension (mm)
B. 1500 / D. 700 / H. 950

FBL167A



Dimensioni prodotto
Product dimension (mm)
B. 1600 / D. 700 / H. 950

FBL187A



Dimensioni prodotto
Product dimension (mm)
B. 1800 / D. 700 / H. 950

FBL207A



Dimensioni prodotto
Product dimension (mm)
B. 2000 / D. 700 / H. 950

FBL107A

codice prodotto product code

FBL127A

codice prodotto product code

FBL147A

codice prodotto product code

FBL157A

codice prodotto product code

FBL167A

codice prodotto product code

FBL187A

codice prodotto product code

FBL207A

codice prodotto product code

NORME CE / CE APPROVED

FBL107A

FBL127A

FBL147A

FBL157A

FBL167A

FBL187A

FBL207A

Peso netto
Net weight (kg)

FBL107A

27,0

FBL127A

30,0

FBL147A

35,0

FBL157A

36,0

FBL167A

38,0

FBL187A

40,0

FBL207A

45,0

- Attrezzatura per uso professionale • Corpo in acciaio inossidabile • Top in inox AISI 304 • Porte scorrevoli • Piedini regolabili • Norme CE
- Professional equipment • Stainless steel material body • Top in inox AISI 304 • Adjustable feet • Sliding doors • CE approved



FBA107



Dimensioni prodotto
Product dimension (mm)
B. 1000 / D. 700 / H. 850

FBA127



Dimensioni prodotto
Product dimension (mm)
B. 1200 / D. 700 / H. 850

FBA147



Dimensioni prodotto
Product dimension (mm)
B. 1400 / D. 700 / H. 850

FBA157



Dimensioni prodotto
Product dimension (mm)
B. 1500 / D. 700 / H. 850

FBA167



Dimensioni prodotto
Product dimension (mm)
B. 1600 / D. 700 / H. 850

FBA187



Dimensioni prodotto
Product dimension (mm)
B. 1800 / D. 700 / H. 850

FBA207



Dimensioni prodotto
Product dimension (mm)
B. 2000 / D. 700 / H. 850

FBA107

codice prodotto product code

FBA127

codice prodotto product code

FBA147

codice prodotto product code

FBA157

codice prodotto product code

FBA167

codice prodotto product code

FBA187

codice prodotto product code

FBA207

codice prodotto product code

NORME CE / CE APPROVED

FBA107

FBA127

FBA147

FBA157

FBA167

FBA187

FBA207

Peso netto
Net weight (kg)

FBA107

50,0

FBA127

59,0

FBA147

66,0

FBA157

70,0

FBA167

75,0

FBA187

82,0

FBA207

91,0

BANCHI ARMADIATI CON ALZATINA

WORK CABINETS WITH RAISED BACK



- Attrezzatura per uso professionale • Corpo in acciaio inossidabile • Top in inox AISI 304 • Porte scorrevoli • Piedini regolabili • Norme CE
- Professional equipment • Stainless steel material body • Top in inox AISI 304 • Adjustable feet • Sliding doors • CE approved



FBA107A



Dimensioni prodotto
Product dimension (mm)
B. 1000 / D. 700 / H. 950

FBA127A



Dimensioni prodotto
Product dimension (mm)
B. 1200 / D. 700 / H. 950

FBA147A



Dimensioni prodotto
Product dimension (mm)
B. 1400 / D. 700 / H. 950

FBA157A



Dimensioni prodotto
Product dimension (mm)
B. 1500 / D. 700 / H. 950

FBA167A



Dimensioni prodotto
Product dimension (mm)
B. 1600 / D. 700 / H. 950

FBA187A



Dimensioni prodotto
Product dimension (mm)
B. 1800 / D. 700 / H. 950

FBA207A



Dimensioni prodotto
Product dimension (mm)
B. 2000 / D. 700 / H. 950

FBA107A

codice prodotto product code

FBA127A

codice prodotto product code

FBA147A

codice prodotto product code

FBA157A

codice prodotto product code

FBA167A

codice prodotto product code

FBA187A

codice prodotto product code

FBA207A

codice prodotto product code

NORME CE / CE APPROVED

FBA107A

FBA127A

FBA147A

FBA157A

FBA167A

FBA187A

FBA207A

Peso netto
Net weight (kg)

FBA107A

52,0

FBA127A

60,0

FBA147A

69,0

FBA157A

73,0

FBA167A

78,0

FBA187A

84,0

FBA207A

93,0

PENSILI CON ANTE SCORREVOLI

WALL CABINETS WITH SLIDING DOORS



- Attrezzatura per uso professionale • Struttura in acciaio inossidabile • Ante scorrevoli • Ripiano intermedio e staffe di fissaggio a parete incluse • Norme CE
- Professional equipment • Stainless steel material body • Sliding doors • Middle shelf and mounting brackets included • CE approved



FPAS60



Dimensioni prodotto
Product dimension (mm)
B. 600 / D. 400 / H. 650

FPAS80



Dimensioni prodotto
Product dimension (mm)
B. 800 / D. 400 / H. 650

FPAS100



Dimensioni prodotto
Product dimension (mm)
B. 1000 / D. 400 / H. 650

FPAS120



Dimensioni prodotto
Product dimension (mm)
B. 1200 / D. 400 / H. 650

FPAS140



Dimensioni prodotto
Product dimension (mm)
B. 1400 / D. 400 / H. 650

FPAS160



Dimensioni prodotto
Product dimension (mm)
B. 1600 mm

FPAS180



Dimensioni prodotto
Product dimension (mm)
B. 1800 / D. 400 / H. 650

FPAS200



Dimensioni prodotto
Product dimension (mm)
B. 2000 / D. 400 / H. 650

FPAS60

codice prodotto product code

FPAS80

codice prodotto product code

FPAS100

codice prodotto product code

FPAS120

codice prodotto product code

FPAS140

codice prodotto product code

FPAS160

codice prodotto product code

FPAS180

codice prodotto product code

FPAS200

codice prodotto product code

NORME CE / CE APPROVED

FPAS60

FPAS80

FPAS100

FPAS120

FPAS140

FPAS160

FPAS180

FPAS200

Peso netto
Net weight (kg)

FPAS60

20,0

FPAS80

23,0

FPAS100

27,0

FPAS120

31,0

FPAS140

34,0

FPAS160

38,0

FPAS180

42,0

FPAS200

45,0

CARRELLI DI SERVIZIO

SERVICE TROLLEY



• Attrezzatura per uso professionale • Corpo in acciaio inossidabile • Struttura in tubo stainato tondo \varnothing 25mm • Piani stampati a forma di vassoio con bordi arrotondati, satinati, insonorizzati ed imbullonati al telaio • Paracolpi in gomma grigia • Ruote piroettanti \varnothing 100 mm di cui 2 con freno • Portata complessiva 120 kg • Norme CE

• Professional equipment • Stainless steel material body • Structure in round tubular satin finished stainless steel of 25 mm diameter • Molded tray shaped shelves with rounded edges, satin finished stainless steel, soundproof and bolted to the tray's frame • Grey rubber bumpers • Swivelling 100 mm diameter castors, 2 of wich with brake • Total weight allowance: 120 kg • CE approved



FCRS280



Dimensioni prodotto
Product dimension (mm)
B. 885 / D. 590 / H. 935

FCRS2100



Dimensioni prodotto
Product dimension (mm)
B. 1085 / D. 590 / H. 935

FCRS380



Dimensioni prodotto
Product dimension (mm)
B. 885 / D. 590 / H. 935

FCRS3100



Dimensioni prodotto
Product dimension (mm)
B. 1085 / D. 590 / H. 935

	Peso netto Net weight (kg)	N. ripiani N. of shelves
FCRS280	10,0	2
FCRS2100	12,0	2
FCRS380	13,0	3
FCRS3100	16,0	3

	NORME CE / CE APPROVED
FCRS280 codice prodotto product code	FCRS280
FCRS2100 codice prodotto product code	FCRS2100
FCRS380 codice prodotto product code	FCRS380
FCRS3100 codice prodotto product code	FCRS3100



LAVAMANI

HAND WASHERS



- Attrezzatura per uso professionale • Struttura in acciaio inossidabile AISI 304 • Rubinetti e scarichi inclusi • Norme CE
- Professional equipment • Stainless steel AISI 304 body • Tap and sink included • CE approved



FLM40



Dimensioni prodotto
Product dimension (mm)
B. 400 / D. 400 / H. 310

Peso netto
Net weight (kg)

FLM40

5,5

NORME CE / CE APPROVED

FLM40

codice prodotto product code

FLM40

imported

CONDIZIONI GENERALI DI VENDITA

TERMS AND CONDITIONS

PER ORDINI INFERIORI A € 100,00 NETTI VIENE APPLICATO UN SUPPLEMENTO DI € 20,00 PER GESTIONE ORDINE MS - SUPPLEMENTO PER MOTORI A VOLTAGGIO SPECIALE 5%

CONSEGNA

Spedizioni giornaliera

RESA MERCE

A mezzo corriere in porto franco con addebito in fattura.

Nel caso di materiale danneggiato, ritirarlo con riserva e inviarci immediatamente comunicazione scritta.

La merce in porto franco viaggia assicurata.

PAGAMENTO

Dilazioni di pagamento da definirsi.

Si richiede pagamento in contanti o in contrassegno:

- prime forniture;
- al superamento del fido concesso;
- per l'invio di ricambi;

Tutti i prezzi si intendono IVA ESCLUSA. Il presente LISTINO annulla i precedenti.

Tutte le macchine sono costruite a norma del D.P.R. - 27 aprile n. 547, coperta da assicurazione (Responsabilità civile verso terzi). Le caratteristiche tecniche ed estetiche possono variare a nostro giudizio, senza alcun preavviso. È VIETATA la produzione e la pubblicazione di qualsiasi tipo e forma (internet, cartacea, supporti digitali, etc) anche parziale di testi, prezzi, disegni e immagini, senza preventiva autorizzazione della direzione. Ogni comportamento diverso da quanto sopra, sarà perseguibile penalmente.

FAMA INDUSTRIE si riserva il diritto di apportare modifiche ai prodotti illustrati in questo listino in qualunque momento senza obbligo di preavviso.

PALLET Legno

P1 € 10,00

P2 € 15,00

PALLET in PVC

P3 € 13,00

P4 € 20,00

IMBALLO con Poliuretano Espanso

FC0 € 3,00

FC € 6,00

FC1 € 10,00

FC2 € 15,00

ASSISTENZA TECNICA

A carico del rivenditore per tutta la durata della garanzia.

GARANZIA

1 anno, escluse le parti elettriche.

La merce deve essere resa franco nostro stabilimento con imballo originale, altrimenti non autorizzata.

**ORDERS OF LESS THAN 100€ - 20€ ORDER HANDLING FEE IS CHARGED
WE APPLY 5% SURCHARGE FOR 60 HZ EQUIPMENT**

DELIVERY

Daily shipping

RETURNS

All returns must be carriage free with invoice debit.

Damaged goods have to be collected with reservation, and a written notice has to be sent. Carriage free are covered by insurance.

PAYMENT

Delay of payments to be agreed. Cash or Cash on delivery

payments are required for:

- first supplies;
- exceeding credit limits;
- spare parts dispatch;

Prices quotes are exclusive of V.A.T. The current price list writes off the previous ones.

All machines are manufactured in line with the D.P.R. - Aprile 27 n. 547 standards, covered by insurance (Civil responsibility towards third party). Some technical or aesthetic variations may occur without prior notice. IT IS FORBIDDEN to publish or reproduce in any way (digital format or on the internet) even partially any texts, drawings or images, without any prior authorization of the management. Any behavior not in line with the above mentioned rule will be prosecuted.

FAMA INDUSTRIE reserves the right to modify the products displayed in this price list at any time without any notice obligations.

PALLET (wood)

P1 € 10,00

P2 € 15,00

PALLET (PVC)

P3 € 13,00

P4 € 20,00

PACKAGING (with Expanded Polyurethane) Charges

FC0 € 3,00

FC € 6,00

FC1 € 10,00

FC2 € 15,00

TECHNICAL ASSISTANCE

Must be provided by the seller

GUARANTEE

The company provides 1 year guarantee, except on electric parts. Goods must be returned carriage free to our factory with original packaging, otherwise not authorized.





MADE IN ITALY

famaindustrie.com



FAMA INDUSTRIE SRL
Via Altobelli, 39 - 47924 Rimini (RN)

Tel +39.0541.388222 - 384509
Fax +39.0541.385662
fama@famaindustrie.com